

SPEC for Mass Production

Spec No.	CPD-365458AA-01
Date	May 22, 2024

TYPE : C0500WV65458-BN-AA

<5.0 inch transmissive color TFT with LED backlight>

CONTENTS

1. General description
2. Features
3. Mechanical specification
4. Mechanical dimension
5. Absolute maximum ratings
6. Electrical characteristics
7. Backlight characteristic
8. Module function description
9. LVDS characteristics
10. Power on/off sequence
11. Electro-optical characteristics
12. Reliability
13. Inspection criteria
14. Label description
15. Packaging
16. RoHS compliant warranty
17. Precautions for use
18. Warranty



KYOCERA CORPORATION

Original Issue Date	Designed by: Engineering dept.			Confirmed by: QA dept.
	Prepared	Checked	Approved	Approved
May 22, 2024	<i>T. Nishimura</i>	<i>T. Fukui</i>	<i>M. Kato</i>	<i>T. Sawada</i>

Spec No. CPD-365458AA-01	Part No. C0500WV65458-BN-AA	Page -
-----------------------------	--------------------------------	-----------

Warning

1. This Kyocera LCD module has been specifically designed for use only in electronic devices and industrial machines in the area of audio control, office automation, industrial control, home appliances, etc. The module should not be used in applications where the highest level of safety and reliability are required and module failure or malfunction of such module results in physical harm or loss of life, as well as enormous damage or loss. Such fields of applications include, without limitation, medical, aerospace, communications infrastructure, atomic energy control. Kyocera expressly disclaims any and all liability resulting in any way to the use of the module in such applications.

2. Customer agrees to indemnify, defend and hold Kyocera harmless from and against any and all actions, claims, damages, liabilities, awards, costs, and expenses, including legal expenses, resulting from or arising out of Customer's use, or sale for use, or Kyocera modules in applications.

Caution

1. Kyocera shall have the right, which Customer hereby acknowledges, to immediately scrap or destroy tooling for Kyocera modules for which no Purchase Orders have been received from the Customer in a two-year period.

2. Please note that we may not be able to respond to new environmental regulations after receiving the final mass production order for this product.

Spec No. CPD-365458AA-01	Part No. C0500WV65458-BN-AA	Page -
-----------------------------	--------------------------------	-----------

Revision record

Date		Designed by : Engineering dept.			Confirmed by : QA dept.
		Prepared	Checked	Approved	Approved
Rev. No.	Date	Page	Descriptions		

1. General description

This model is a Color TFT LCD. This main Module has a 5 inch diagonally measured active display area with 800 × RGB × 480 resolutions. Each pixel is divided into Red, Green and Blue sub-pixels and dots that are arranged in vertical stripes. LCD color is determined with Dithering 16.7M Color signal for each pixel.

2. Features

Display mode	Transmissive Type
	a-Si color TFT LCD, FFS normally black
Screen size	5 inches
Display format	Graphic 800*RGB*480 Stripe type
Input data	LVDS 4 lane
Viewing direction	Free
Driver IC	ST7262-G4-G02
Backlight	White LED

3. Mechanical specification

Item	Specifications	Unit
Dimensional outline	115(W)×76(H)×4.46(T)	mm
Resolution	800×RGB×480	dot
Active area	108(W)×64.8(H)	mm
Dot pitch	0.135(W)×0.135 (H)	mm

Note1: Outline exclude FPC

Note2: 1 pixel = 3 dots = Red dot +Green dot +Blue dot.

4. Mechanical dimension

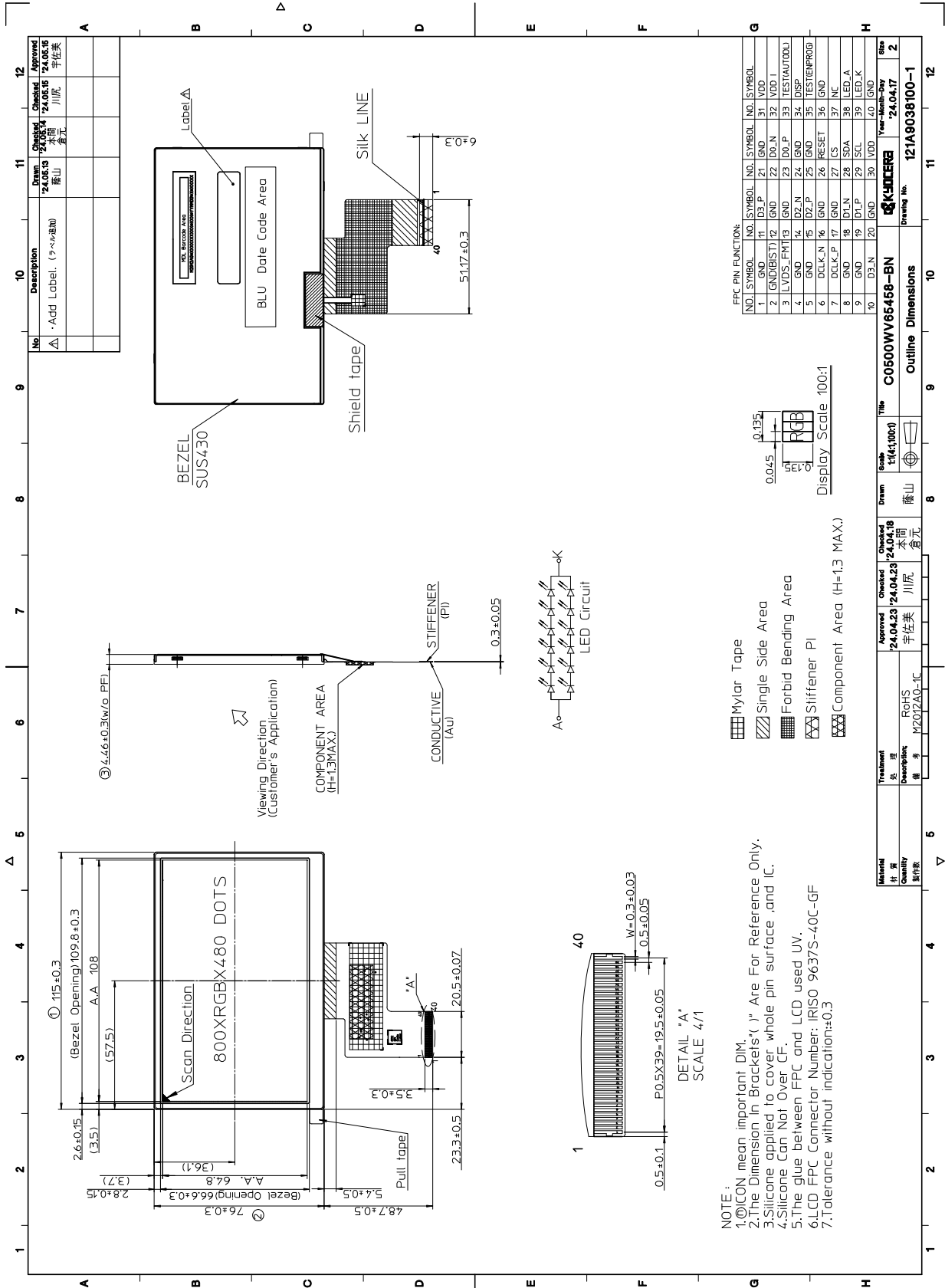

5. Absolute maximum ratings

If the operating condition exceeds the following absolute maximum ratings, the TFT LCD module may be damaged permanently.

Item	Symbol	Condition	Values		Unit	Note
			Min.	Max.		
Power supply voltage	VDD	GND=0	-0.3	4.0	V	
IO supply voltage	VDDI	GND=0	-0.3	4.0	V	
Storage temperature	T _{ST}	-	-30	80	°C	Ambient temperature
Operating temperature	T _{OP}	-	-20	70	°C	Ambient temperature

Note:

All the voltages listed above are with respect to GND=0V.

Device is subject to be damaged permanently if stresses beyond those absolute maximum ratings listed above.

6. Electrical characteristics

Typical operating conditions (DGND=AGND=0V Ta=25°C)

Item	Symbol	Values			Unit	Note
		Min.	Typ.	Max.		
Power supply voltage	V _{DD}	3.2	3.3	3.4	V	
IO supply voltage	V _{DDI}	3.2	3.3	3.4	V	
Power consumption	I _{DD}	-	-	95	mA	
Input signal high voltage	V _{IH}	0.7V _{DDI}	-	V _{DDI}	V	
Input signal low voltage	V _{IL}	GND	-	0.3V _{DDI}	V	
Output signal high voltage	V _{OH}	V _{DDI} -0.4	-	V _{DDI}	V	
Output signal low voltage	V _{OL}	GND	-	GND+0.4	V	

7. Backlight characteristic

Item	Symbol	Min	Typ	Max	Unit
Backlight power supply	V_{LED}	14.4	-	19.8	V
Backlight current	I_{LED}	-	100	-	mA
Life time	-	50,000	-	-	hrs

- Test Instrument: BM-7 (Distance =500mm; Field = 1°)
- Light Source: LED*12(White)
- Conditions: $V_{LED} = 16.2V \sim 19.8V$; $I_{LED} = 50mA/line$
- Measure Brightness: 1 ~ 9
- Uniformity = (Min. Brightness / Max. Brightness) *100%
- Uniformity $\geq 70\%$
- LED life time is defined as the time when the brightness become 50% of initial valve.

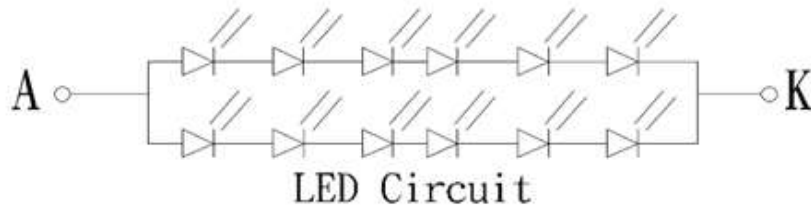
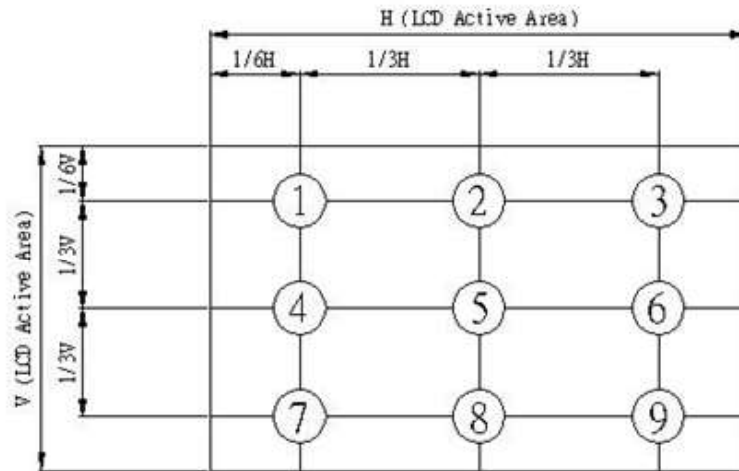

8. Module function description

8-1 LCM Pin description

Pin NO.	Pin Name	I/O	Pin Function	Remark
1	GND	P	System Ground	
2	GND(BIST)	P	BIST function control pin Please connect to GND for normal display.	
3	LVDS_FMT	I	L: VESA Mode. H: JEIDA Mode(Default).	
4	GND	P	System Ground	
5	GND	P	System Ground	
6	DCLK_N	I	LVDS interface: DCLKN	
7	DCLK_P	I	LVDS interface: DCLKP	
8	GND	P	System Ground	
9	GND	P	System Ground	
10	D3_N	I	LVDS interface data input D3N	
11	D3_P	I	LVDS interface data input D3P	
12	GND	P	System Ground	
13	GND	P	System Ground	
14	D2_N	I	LVDS interface data input D2N	
15	D2_P	I	LVDS interface data input D2P	
16	GND	P	System Ground	
17	GND	P	System Ground	
18	D1_N	I	LVDS interface data input D1N	
19	D1_P	I	LVDS interface data input D1P	
20	GND	P	System Ground	
21	GND	P	System Ground	
22	D0_N	I	LVDS interface data input D0N	
23	D0_P	I	LVDS interface data input D0P	
24	GND	P	System Ground	
25	GND	P	System Ground	
26	RESET	I	Reset pin.	
27	CS	I	Serial communication chip selection. Please connect to VDDI when not in used.	
28	SDA	I/O	Serial communication clock input and output. please leave this pin open.	
29	SCL	I	Serial communication clock input. please leave this pin open.	
30	VDD	P	Power supply	
31	VDD	P	Power supply	
32	VDDI	P	Power supply	

33	TEST(AUTODL)	T	Reserved for testing only, please leave this pin open.	
34	DISP	I	Standby pin	Active low
35	TEST(ENPROG)	T	Reserved for testing only, please leave this pin open.	
36	GND	P	System Ground	
37	NC	-	No Connect	
38	LED_A	P	LED Backlight Anode	
39	LED_K	P	LED Backlight Cathode	
40	GND	P	System Ground	

I : Input, I/O : Input/output, P : Power, T : Test Pin

9. LVDS characteristics

9-1 LVDS mode DC Electrical characteristics

Item	Symbol	Min.	Typ.	Max.	Unit	Conditions
Differential Input High Threshold Voltage	R_{xVTH}	-	-	0.1	V	$R_{xVCM} = 1.2V$
Differential Input Low Threshold Voltage	R_{xVTL}	-0.1	-	-	V	
Input Voltage Range (Singed-End)	R_{xVIN}	0	-	VDD-1.0	V	
Differential Input Common Mode Voltage	R_{xVCM}	$ V_{ID} /2$	-	$2.4 \cdot V_{ID} /2$	V	
Differential Input Voltage	$ V_{ID} $	0.2	-	0.6	V	
Differential Input Leakage Current	$R_{V_{xIIZ}}$	-10	-	10	μA	
LVDS Digital Operating Current	I_{VDD_LVDS}	-	10	15	mA	
LVDS Digital Stand-by Current	I_{STBD_LVDS}	-	10	50	μA	
Differential Input Termination Resistance	R_{ID}	90	100	110	Ω	

Single End Signals

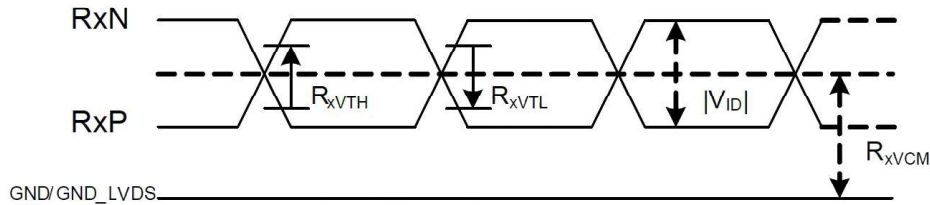

Differential Signals

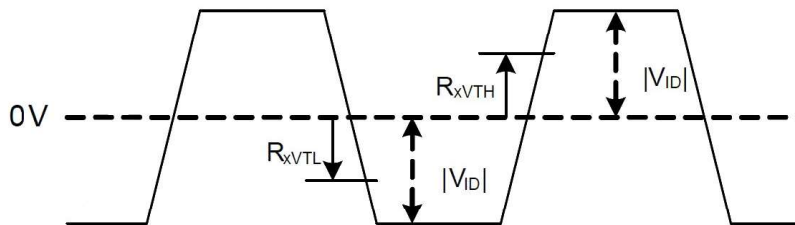

9-2 LVDS mode AC electrical characteristics

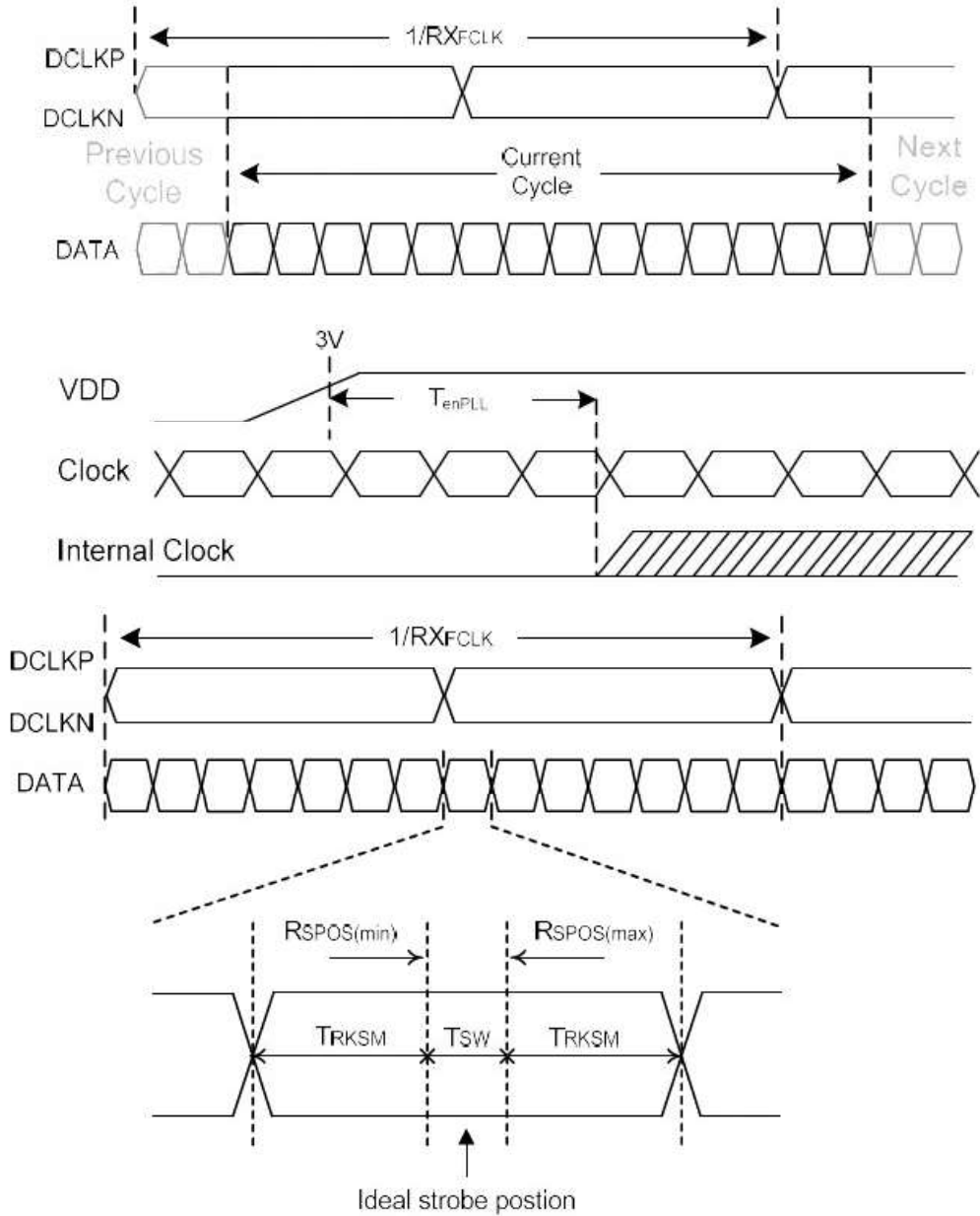

RRKSM: Receiver strobe margin

RSPOS: Receiver strobe position

TSW: Strobe width (internal DATA sampling window)

Item	Symbol	Min.	Typ.	Max.	Unit	Conditions
Clock Frequency	RXFCLK	23	25	27	MHz	
Input Data Skew Margin	TRSKM	400			ps	
Clock High Time	TLVCH	4/(7 x RXFCLK)			ns	
Clock Low Time	TLVCL	3/(7 x RXFCLK)			ns	
PLL Wake-up Time	TenPLL			150	us	
LVDS Spread Spectrum Clocking (SSC) Tolerance of LVDS Receiver						
Modulation Frequency	SSCMF			100	KHz	
Modulation Rate	SSCMR			+/-3	%	

9-3 4-Lane data format color bit map

4 Lane VESA Data Format Color Bit Map

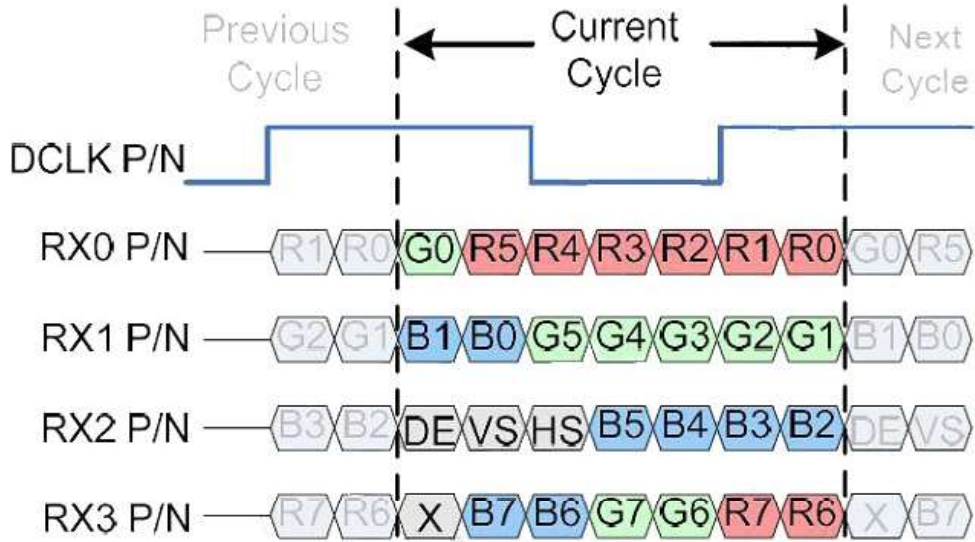

4 Lane JEIDA Data Format Color Bit Map

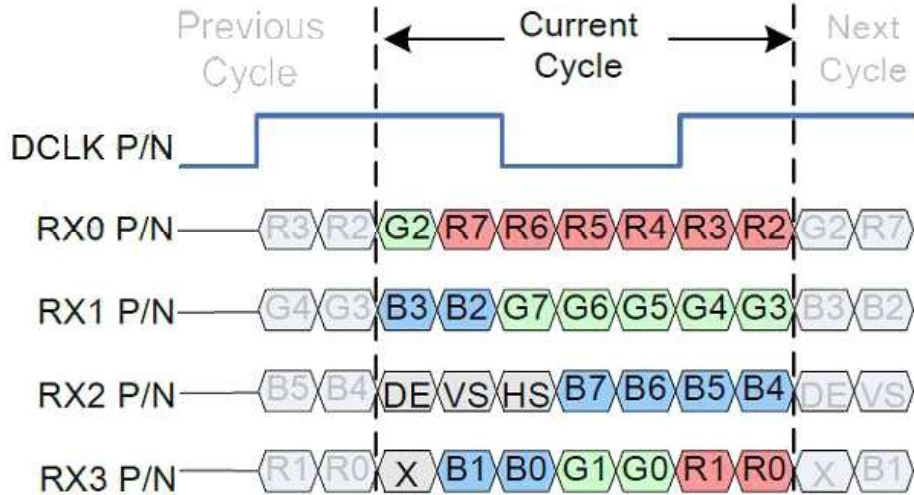

10. Power on/off sequence

10-1 Power on sequence

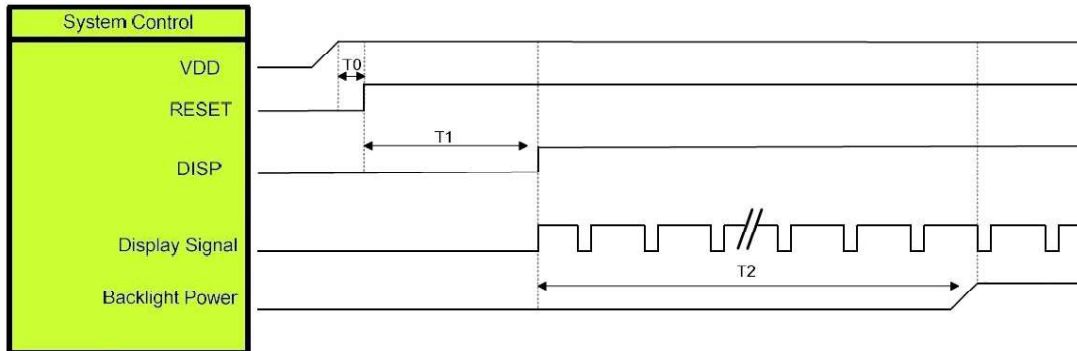

Symbol	Description	Min. Time	Unit
T0	System power stability to RESET signal	0	ms
T1	RESET= "High" to DISP="High"	10	ms
T2	Display Signal output to Backlight Power on	250	ms

10-2 Power off sequence

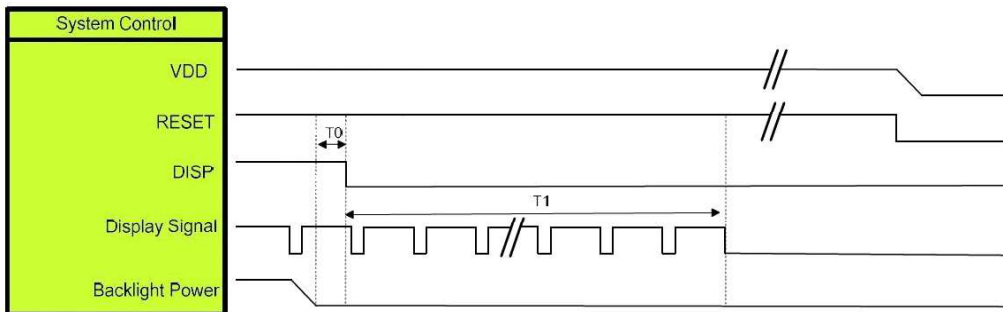

Symbol	Description	Min. Time	Unit
T0	Backlight Power off to DISP="Low"	5	ms
T1	DISP="Low" to IC internal voltage discharge complete	100	ms

Note: When DISP pull "H" or "L", IC will execute the internal power on or power off procedures.
Please be careful about the timing of DISP and do not interrupt it during power on or power off procedure, otherwise unexpected errors will occur.

11. Electro-optical characteristics

Parameter		Symbol	Min.	Typ.	Max.	Unit	Note
Luminance of white		Lwh	800	900	-	cd/m ²	Note 3
Contrast Ratio		CR	400	500	-	-	
CIE color Coordinates	White	x	0.26	0.31	0.36	-	CA-310 Note 1
		y	0.28	0.33	0.38		
	Red	x	0.54	0.59	0.64		
		y	0.32	0.37	0.42		
	Green	x	0.28	0.33	0.38		
		y	0.55	0.60	0.65		
Blue	x	0.09	0.14	0.19			
	y	0.02	0.07	0.12			
Response Time (25°C)		Tr+Tf	-	35	40	ms	Note 2
Uniformity		%	70%	-	-	-	-

Viewing angle range	$\phi = 0^\circ$ (6")	$\phi = 90^\circ$ (3")	$\phi = 180^\circ$ (12")	$\phi = 270^\circ$ (9")	Note
$\theta=0$ (25°C), CR ≥ 10	80	80	80	80	Note 5

1) Test equipment setup

- After stabilizing and leaving the panel alone at a given temperature for 30 minutes, the measurement should be executed. Measurement should be executed in a stable, windless, and dark room. Optical specifications are measured by CA310.

2) Definition of response time: T_R and T_F

The figure below is the output signal of the photo detector.

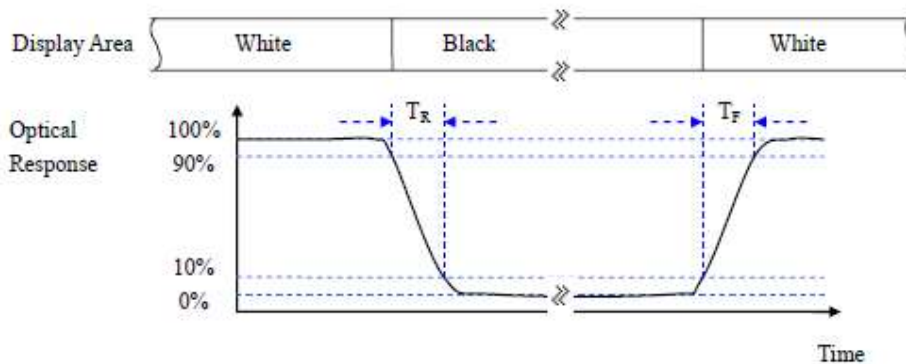

3) Definition of contrast ratio:

$$\text{Contrast ratio (CR)} = \frac{\text{Brightness measured when LCD is at "white state"}}{\text{Brightness measured when LCD is at "black state"}}$$

White $V_i = V_{i50\%} \pm 1.5V$

Black $V_i = V_{i50\%} \mp 2.0V$

“±” means that the analog input signal swings in phase with VCOM signal.

“∓” means that the analog input signal swings out of phase with VCOM signal.

$V_{i50\%}$: The analog input voltage when transmission is 50%.

The 100% transmission is defined as the transmission of LCD panel when all the input terminals of module are electrically opened.

4) Measured at the center area of the panel when all the input terminals of LCD panel are electrically opened.

5) Definition of viewing angle:

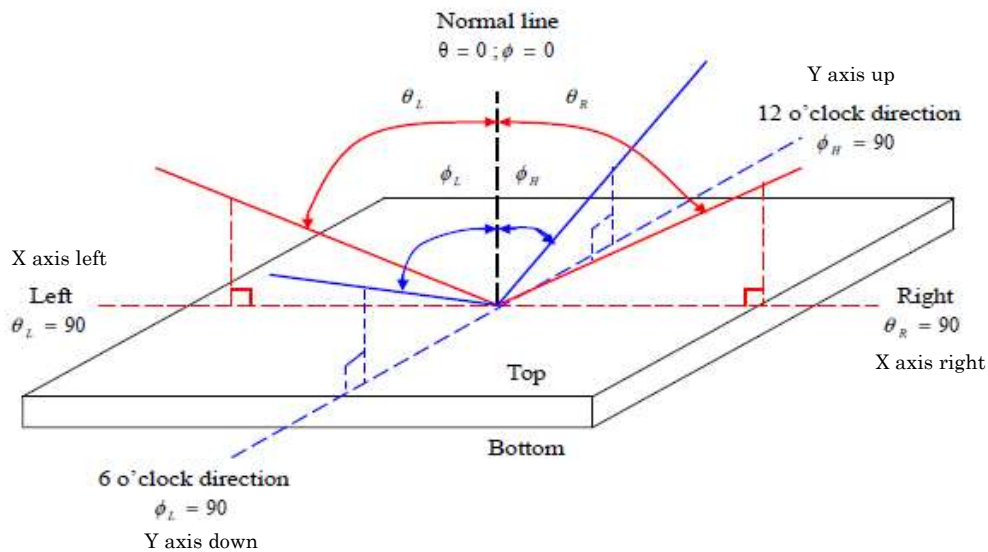

12. Reliability

12-1 Tests

NO.	Item	Condition	Criterion
1	High Temperature Operating	70°C, 240 hrs	1. No defect of operational function in room temperature is allowable. (23±5°C). 2. Leakage current should be below double of initial value.
2	Low Temperature Operating	-20°C, 240 hrs	
3	High Temperature Non-Operating	80°C, 240 hrs	
4	Low Temperature Non-Operating	-30°C, 240 hrs	
5	High Temperature/ Humidity Operating	60°C, 90%RH 240 hrs	
6	Temperature Shock Non-Operating	-30°C ↔ 80°C (60min) (5min) (60min) 100 CYCLES	
7	Electrostatic Discharge Test Non-Operating	HBM: 2kv (C=100pF:R=1500Ω Pin to Pin/Vdd & Vss Non-Operating)	
8	Image sticking	25°C /4 hours, checkerboard pattern, Judge by N.D 10% filter invisible at 128 grayscale.	

Note1: Test after 24 hours in room temperature.

Note2: The sampling above is individually for each reliability testing condition.

Note3: The color fading of polarizing filter should not care.

Note4: The entire reliability-testing chamber above is using D.I. water. (Min value: 1.0 M ohm·cm)

Note5: In case of malfunction defect caused by ESD damage, if it would be recovered to normal state after resetting, it would be judged as a good part.

13. Inspection criteria

13-1. Inspection Conditions

13-1.1 Environmental conditions

The environmental conditions for inspection shall be as follows

Room temperature: $23\pm 5^{\circ}\text{C}$

Humidity: $50\pm 20\%RH$

13-1.2 The external visual inspection

With a single 1000 ± 200 lux fluorescent lamp as the light source, the inspection was in the distance of 30cm or more from the LCD to the inspector's eyes.

13-2 Light method

1. Inspection is implemented over 30cm vertical distance and 30° incidence under 1000 ± 200 lux. (As showed below)
2. Viewing direction for inspection over 30cm far and is 45° against from LCD (As showed below)

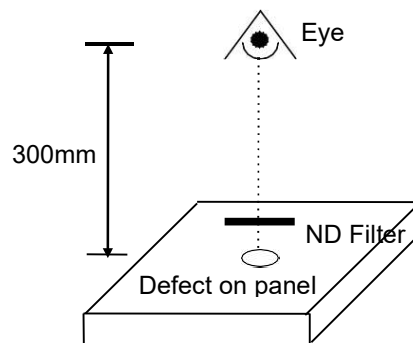

13-3 Classification of defects

13-3.1 Major defect

A major defect refers to a defect that may substantially degrade usability for product applications.

13-3.2 Minor defect

A minor defect refers to a defect which is not considered to be able substantially degrade the product application or a defect that deviates from existing standards almost unrelated to the effective use of the product or its operation.

Notes: If the LCD/LCM's cosmetic and display performance do not specify in "inspection criterion", it should be based on these delivered samples.

13-4 Sampling & acceptable quality level

Level II, ANSI / ASQ Z1.4

	Major	Minor
Cosmetic	0.4	1.0
Electrical-display	0.15	0.15

13-5 Definition of inspection area



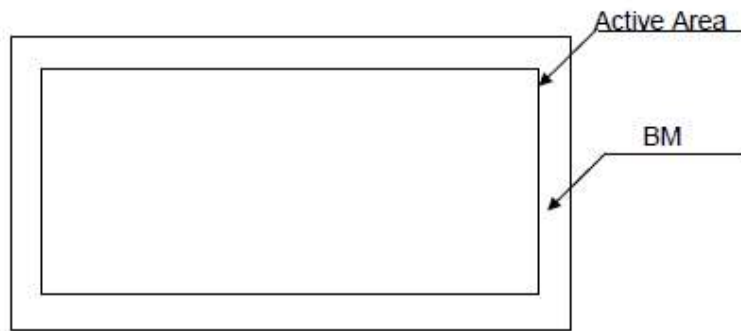

A.A: Active Area

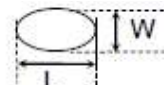

13-6 Inspection item and criteria

13-6.1 Visual inspection criterion in cosmetic

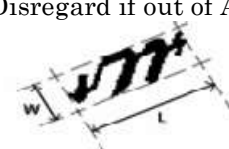
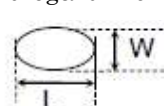
(1) LCM appearance defect within A.A.







No	Defect	Criteria		Remark
1	Round type (Minor)	Spec.	Permissible Qty	1. $\phi = (L+W)/2$, L: Length, W: Width 2. Disregard if out of A.A. 
		$\psi \leq 0.15\text{mm}$	Disregard	
		$0.15\text{mm} < \psi \leq 0.5\text{mm}$	3	
		$\psi > 0.5\text{mm}$	0	
2	Line type Scratch (Minor)	Spec.	Permissible Qty	1. L: Length, W: Width 2. Disregard if out of A.A. 
		$W \leq 0.03\text{mm}$	Disregard	
		$0.03\text{mm} < W \leq 0.05\text{mm}$ and $L \leq 10\text{mm}$ and $d > 5\text{mm}$	4	
		$W > 0.05\text{mm}$ or $L > 10\text{mm}$	0	
3	Fiber (Minor)	Spec.	Permissible Qty	1. L: Length, W: Width 2. Disregard if out of A.A. 
		$W \leq 1.0\text{mm}$ and $L \leq 1.5\text{mm}$	4	
		$W > 1.0\text{mm}$ or $L > 1.5\text{mm}$	0	
4	Polarizer bubble (Minor)	Spec.	Permissible Qty	1. $\phi = (L+W)/2$, L: Length, W: Width 2. Disregard if out of A.A. 
		$\phi < 0.2\text{mm}$	Disregard	
		$0.2\text{mm} \leq \phi \leq 0.5\text{mm}$	2	
5	Polarizer Dent, Bulge (Minor)	Spec.	Permissible Qty	1. $\phi = (L+W)/2$, L: Length, W: Width 2. Disregard if out of A.A. 
		$\phi \leq 0.25\text{mm}$	Disregard	
		$0.25\text{mm} \leq \psi \leq 0.5\text{mm}$	4	
		$\phi > 0.5\text{mm}$	0	

(2) FPC

No	Defect	Criteria		Remark
1	Copper peeling (Minor)	Copper peeling	【Reject】	

13-6.2 LCM electrical criterion

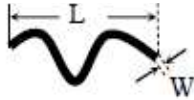
(1) LCM electrical criterion

No	Defect	Criteria		Remark
1	No display (Major)	Not allowed		
2	Missing line (Major)	Not allowed		
3	Darker or lighter line (Major)	Not allowed		
4	Round type (Minor)	Spec.	Permissible Q'ty	1. $\psi=(L+W)/2$, L: Length, W: Width 2. Disregard if out of A.A. 
		$\phi < 0.15\text{mm}$	Disregard	
		$0.15\text{mm} \leq \phi \leq 0.5\text{mm}$	3	
		$\phi > 0.5\text{mm}$	0	
5	Line type, Scratch (Minor)	Spec.	Permissible Q'ty	1. L: Length, W: Width 2. Disregard if out of A.A. 
		$W \leq 0.03\text{mm}$	Disregard	
		$0.03\text{mm} < W \leq 0.05\text{mm}$ and $L \leq 10\text{mm}$ and $d > 5\text{mm}$	4	
		$W > 0.05\text{mm}$ or $L > 10\text{mm}$	0	
6	Fiber (Minor)	Spec.	Permissible Q'ty	1. L: Length, W: Width 2. Disregard if out of A.A. 
		$W \leq 1.0\text{mm}$ and $L \leq 1.5\text{mm}$	4	
		$W > 1.0\text{mm}$ or $L > 1.5\text{mm}$	0	
7	Bright / Dark point (Minor)	Spec.	Permissible Q'ty	1. 1 sub-pixel: 1R or 1G or 1B 2. Point defect area $\geq 1/2$ sub pixel. 3. Distance between two points $> 15\text{mm}$ 
		Bright point	0	
		Dark dot point	2	
		Bright +Dark point	2	
		Two adjacent dot	0	

No	Defect	Criteria		Remark	
8	Weak Bright dot (Minor)	$\geq 1/2\text{dot}$	Refer to Bright point criteria		Point defect area < 1/2 sub pixel.
		< 1/2dot	$n \leq 5$	By 5% ND filter invisible	
			$n > 5$	Visually Not allowed	
9	Mura (Minor)	By 5% ND filter invisible			





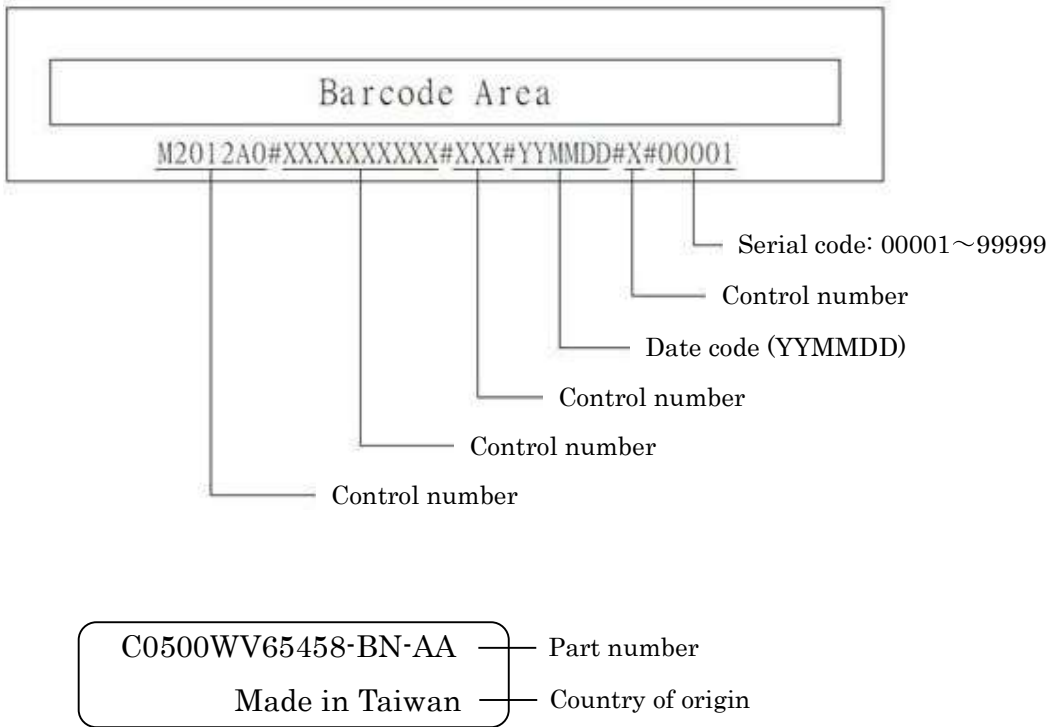

13-6.3 Others

1. Issues that are not defined in this document shall be discussed and agreed with both parties.
(Customer and supplier)
2. Unless otherwise agreed upon in writing, the criteria shall be applied to both parties.
(Customer and supplier)
3. Polarizer, more than 0.5mm in size reduction rejected.

14. Label description

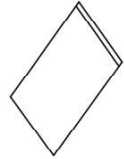

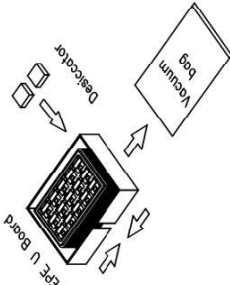
15. Packaging

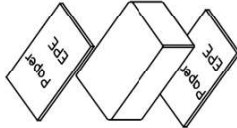
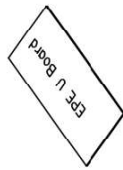
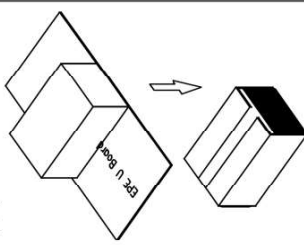
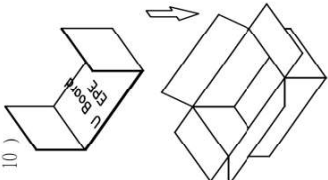
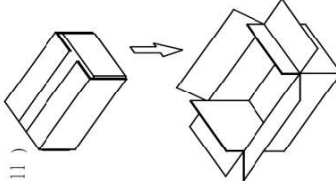
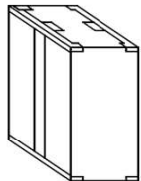
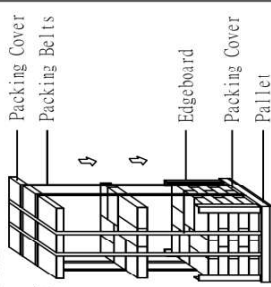
<p>Package Order (1)~(13)</p>	<p>(1) TRAY No.: P_0M2012A01</p> <div style="display: flex; justify-content: space-around;"> <div style="text-align: center;">  <p>② 180° Revers</p> </div> <div style="text-align: center;">  <p>① Normal</p> </div> </div> <p>TRAY</p>	<p>(2) Order</p>  <p>6 pcs tray + 1 pcs empty tray</p>	<p>(3) Vacuum bag</p> 	<p>(4) Desiccator</p> 	<p>(5) Products And Desiccators Put In Vacuum Bag</p> 	<p>(6) Attach A Label To Package Bag</p> 	<p>(7)</p> 	<p>(8)</p> 	<p>(9)</p> 	<p>(10)</p> 	<p>(11)</p> 	<p>(12) Package Quantity Products: 48 Pcs/Carton 1 Tray Contain : 4 Pcs 12 Contained Trays + 1 Empty Tray</p> 	<p>(13) Pallet Carton Quantity Products: 48 Cartons/1 Pallet Cartons Turn 180° (One Layer Of 8 Cartons & Only Put 6 Layers)</p> 																																																																			
<p>NOTE:</p> <ol style="list-style-type: none"> 1. Tape On Carton ° 2. Stored Up The By 13 Trays Then Put It In To Antistatic Bag And Seal It Aswell 3. Vacuum Packaging Shipment ° 										<p>REVISION RECORD</p> <table border="1" style="width: 100%; border-collapse: collapse;"> <tr><td>A</td><td></td><td></td><td></td><td></td></tr> <tr><td>B</td><td></td><td></td><td></td><td></td></tr> <tr><td>C</td><td></td><td></td><td></td><td></td></tr> <tr><td>D</td><td></td><td></td><td></td><td></td></tr> <tr><td>E</td><td></td><td></td><td></td><td></td></tr> </table>		A					B					C					D					E					<p>SCALE</p> <table border="1" style="width: 100%; border-collapse: collapse;"> <tr><td>mm</td><td></td></tr> </table>		mm		<p>TOLERANCE</p> <table border="1" style="width: 100%; border-collapse: collapse;"> <tr><td>08.11.23</td><td></td></tr> </table>		08.11.23		<p>ORG DATE</p> <table border="1" style="width: 100%; border-collapse: collapse;"> <tr><td>Y.C. Tsai</td><td></td></tr> </table>		Y.C. Tsai		<p>DRAWN BY</p> <table border="1" style="width: 100%; border-collapse: collapse;"> <tr><td></td><td></td></tr> </table>				<p>CHECKED BY</p> <table border="1" style="width: 100%; border-collapse: collapse;"> <tr><td></td><td></td></tr> </table>				<p>CONCURRED BY</p> <table border="1" style="width: 100%; border-collapse: collapse;"> <tr><td></td><td></td></tr> </table>				<p>APPROVED BY</p> <table border="1" style="width: 100%; border-collapse: collapse;"> <tr><td></td><td></td></tr> </table>				<p>DWG NO.</p> <table border="1" style="width: 100%; border-collapse: collapse;"> <tr><td>M01200-1A Package</td><td></td></tr> </table>		M01200-1A Package		<p>DCN</p> <table border="1" style="width: 100%; border-collapse: collapse;"> <tr><td>A4</td><td></td></tr> </table>		A4		<p>VERSION</p> <table border="1" style="width: 100%; border-collapse: collapse;"> <tr><td>P. 1 OF 1</td><td></td></tr> </table>		P. 1 OF 1		<p>Package Drawing</p> <table border="1" style="width: 100%; border-collapse: collapse;"> <tr><td>A</td><td></td></tr> </table>		A	
A																																																																																
B																																																																																
C																																																																																
D																																																																																
E																																																																																
mm																																																																																
08.11.23																																																																																
Y.C. Tsai																																																																																
M01200-1A Package																																																																																
A4																																																																																
P. 1 OF 1																																																																																
A																																																																																

16. RoHS compliant warranty

RoHS Hazardous substances including:

- Cd < 100 ppm
- Pb < 1000 ppm
- Hg < 1000 ppm
- Cr +6 < 1000 ppm
- PBDE < 1000 ppm
- PBB < 1000 ppm

17. Precautions for use

17-1 Safety

- (1) Do not swallow any liquid crystal, even if there is no proof that liquid crystal is poisonous.
- (2) If the LCD panel breaks, be careful not to get liquid crystal to touch your skin.
- (3) If skin is exposed to liquid crystal, wash the area thoroughly with alcohol or soap.

17-2 Storage conditions

- (1) Store the panel or module in a dark place where the temperature is $23\pm 5^{\circ}\text{C}$ and the humidity is below $50\pm 20\% \text{RH}$.
- (2) Store in anti-static electricity container.
- (3) Store in clean environment, free from dust, active gas, and solvent.
- (4) Do not place the module near organics solvents or corrosive gases.
- (5) Do not crush, shake, or jolt the module.
- (6) Do not exposed to direct sun light of fluorescent lamps.

17-3 Installing LCD module

Attend to the following items when installing the LCM.

- (1) Cover the surface with a transparent protective plate or touch panel to protect the polarizer and LC cell.

17-4 Precautions for operation

- (1) Viewing angle varies with the change of liquid crystal driving voltage (V_0).
Adjust V_0 to show the best contrast.
- (2) Driving the LCD in the voltage above the limit will shorten its lifetime.
- (3) Response time is greatly delayed at temperature below the operating temperature range. However, this does not mean the LCD will be out of the order. It will recover when it returns to the specified temperature range.
- (4) When turning the power on, input each signal after the positive/negative voltage becomes stable.
- (5) Do not apply water or any liquid on product which composed of T/P.

17-5 Handling precautions

- (1) Avoid static electricity which can damage the CMOS LSI; please wear the wrist strap when handling.
- (2) The polarizing plate of the display is very fragile. So, please handle it very carefully.
- (3) Do not give external shock.
- (4) Do not apply excessive force on the surface; it may cause display abnormal.
- (5) Do not wipe the polarizing plate with a dry cloth, as it may easily scratch the surface of plate.
- (6) Do not use ketonics solvent & Aromatic solvent, use with a soft cloth soaked with a cleaning naphtha solvent.
- (7) Do not operate it above the absolute maximum rating.
- (8) Do not remove the panel or frame from the module.
- (9) Do not apply water or any liquid on product, which composed of T/P.

17-5.1 Handling precaution for LCD

LCM is easy to be damaged.

Please note below and be careful for handling.

Correct handling:

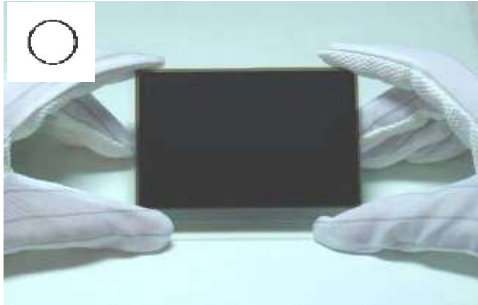

As above photo, please handle with anti-static gloves around LCD edges.

Incorrect handling:



Please don't stack the LCDS.

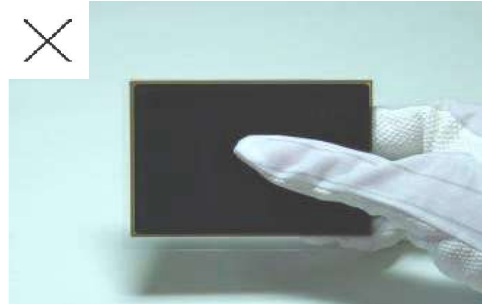

Please don't hold the surface of LCD.

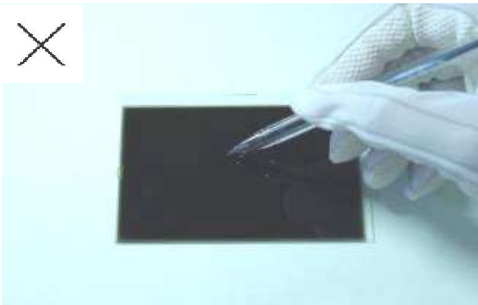

Please don't operate with sharp stick without such as pens.

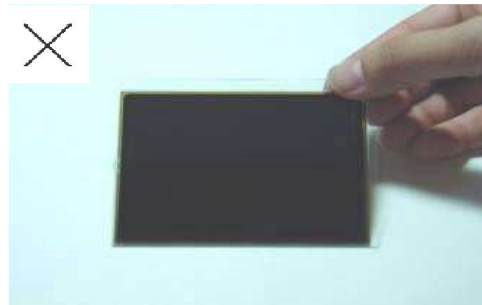

Please don't touch ITO glass anti-static gloves.

17-5.2 Handling precaution for LCM

LCM is easy to be damaged.

Please note below and be careful for handling.

Correct handling:



As above picture, please handle with anti-static gloves around LCM edges.

Incorrect handling:

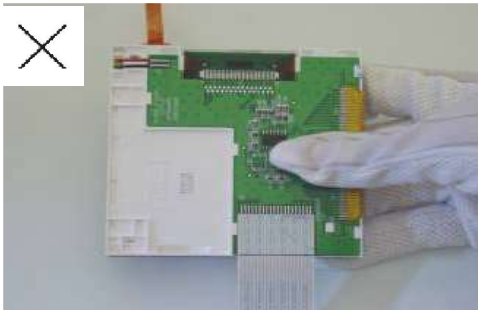

Please don't touch IC directly.

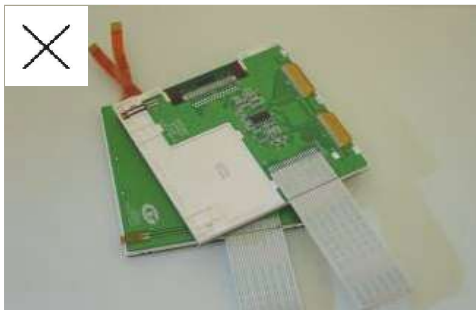

Please don't stack LCM.

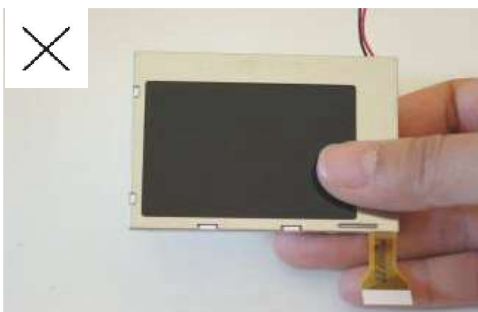

Please don't hold the surface of panel.



Please don't stretch interface of output, such as FPC cable.

18. Warranty

18-1. Incoming inspection

Please inspect the LCM within one month after your receipt.

18-2. Production warranty

Kyocera warrants its LCM for a period of 12 months from the ship date. Kyocera shall, by mutual agreement, replace or re-work defective LCM that is shown to be Kyocera's responsibility.

X-ON Electronics

Largest Supplier of Electrical and Electronic Components

Click to view similar products for [Display Modules](#) category:

Click to view products by [Kyocera Display](#) manufacturer:

Other Similar products are found below :

[P6171DPR-DC-U](#) [P6191PR-DC-U-V3](#) [17978](#) [20135](#) [MIKROMEDIA 3 FOR PIC32MZ CAPACITIVE FPI](#) [19885](#)

[RL0F00101000JGDAASA00](#) [1500CSH](#) [MOD-OLED-128x64](#) [ULCD-104D](#) [ULCD-104DCT](#) [GEN4-ESP32-50CT](#) [GEN4-ESP32-50CT-CLB](#)

[GEN4-ESP32-70](#) [GEN4-ESP32-50T](#) [GEN4-ESP32-24](#) [GEN4-ESP32-35CT](#) [GEN4-ESP32-32](#) [GEN4-ESP32-43T](#) [GEN4-ESP32-35](#) [GEN4-](#)

[ESP32-32CT](#) [GEN4-ESP32-24CT](#) [GEN4-ULCD-43DT-HR](#) [GEN4-ESP32-43CT](#) [ESP32-90CT](#) [GEN4-ESP32-50](#) [GEN4-ESP32-32CT-CLB](#)

[ESP32-90T](#) [DM2-170H-R10](#) [gen4-uLCD-70P4CT-CLB](#) [6SL32550AA004JA2](#) [6SL32550AA004CA1](#) [3D32HK-200](#) [11769](#) [MIKROMEDIA](#)

[FOR DSPIC33](#) [MIKROMEDIA FOR PIC24](#) [MIKROMEDIA FOR PIC32](#) [MIKROMEDIA FOR STELLARIS M3](#) [MIKROMEDIA HMI 3.5](#)

[RES](#) [MIKROMEDIA HMI 5](#) [MIKROMEDIA PLUS FOR FT90X](#) [MIKROMEDIA PLUS FOR PIC32MX7 SHIELD](#) [MIKROMEDIA 5 FOR](#)

[TIVA SHIELD](#) [MIKROMEDIA CONNECT SHIELD](#) [MIKROMEDIA FOR ARM](#) [MIKROMEDIA FOR PSOC5LP](#) [MIKROMEDIA HMI 4.3](#)

[UXB](#) [MIKROMEDIA HMI 5 RES](#) [MIKROMEDIA HMI 5 UXB](#) [MIKROMEDIA HMI 7](#)