

# LCD Module Technical Specification

First Edition  
Jan. 18, 2016

Final Revision  
Mar. 10, 2016

Type No. **T-51750GD065J-LW-BHN**

Customer : **STANDARD**

Customer's Product No : -----

## KYOCERA Display Corporation

Approved :



Checked :



Prepared :



**APPROVED**

By

Signature :

Date :

Please return this specification within two month with your signature.  
If not returned within two month, specification will be considered  
as having been accepted.

# Table of Contents

- 1. Application ..... 3
- 2. General Specifications ..... 3
- 3. Operating Condition ..... 3
- 4. Dimensional Outline ..... 4
- 5. Block Diagram ..... 5
- 6. Pin Assignment ..... 6
- 7. Electrical Specifications ..... 8
- 8. Optical Specifications ..... 17
- 9. Test ..... 22
- 10. Appearance Standards ..... 23
- 11. Code System of Production Lot ..... 28
- 12. Type Number ..... 28
- 13. Applying Precautions ..... 28
- 14. Precautions Relating Product Handling ..... 29
- 15. Warranty ..... 30

## Revision History

| Rev. | Date          | Page | Comment   |
|------|---------------|------|---|
| 01   | Mar. 10, 2016 | 8    | 7.2. DC characteristics<br>(1) TFT-LCD Delete ( ) |
|      |               | 17   | 8. Optical Specifications<br>Delete ( )           |

## 1. Application

This specification applies to 6.5"color TFT-LCD module With touch panel (T-51750GD065J-LW-BHN).

## 2. General Specifications

|                      |  |
|----------------------|--|
| Resolution           | : 640 x 3 [R.G.B] (W) x 480 (H) dots   |
| Dot pitch            | : 0.069 x 3 [R.G.B] (W) x 0.207 (V) mm   |
| Pixel arrangement    | : RGB-Stripe   |
| Color depth          | : 262,144 colors   |
| Active Viewing Area  | : 132.5 (W) x 99.4 (H) mm  |
| Outline dimensions * | : 158.0 (W) x 120.36 (H) x 12.15 (D) mm<br>* Excluding backlight cables.   |
| Weight               | : 280 g max.   |
| LCD type             | : Normally white-mode / Transmissive   |
| Viewing angle        | : 6:00   |
| Interface            | : 18-bit parallel data transfer (6-bit / color)  |
| Backlight            | : LED Backlight / White  |
| Surface Treatment    | : AG Coating   |
| Drawings             | : Dimensional Outline T-51750BH base   |
| RoHS regulation      | : To our best knowledge, this product satisfies material requirement of RoHS regulation.<br>Our company is doing the best efforts to obtain the equivalent certificate from our suppliers. |

## 3. Operating Conditions

| Item                        |            | Conditions      | Temperature Range | Remark  |
|-----------------------------|------------|-----------------|-------------------|---------|
| Operating Temperature Range | LCD Module | Display Surface | -20~70°C          | Note2-1 |
| Storage Temperature Range   | LCD Module | Display Surface | -20~70°C          | Note2-2 |

Note2-1: Operating temperature range defines the operation only. Electrical and optical specification can be guaranteed at the condition that ambient temperature is 25°C.

Note2-2: Backlight is not activated.

# 4. Dimensional Outline

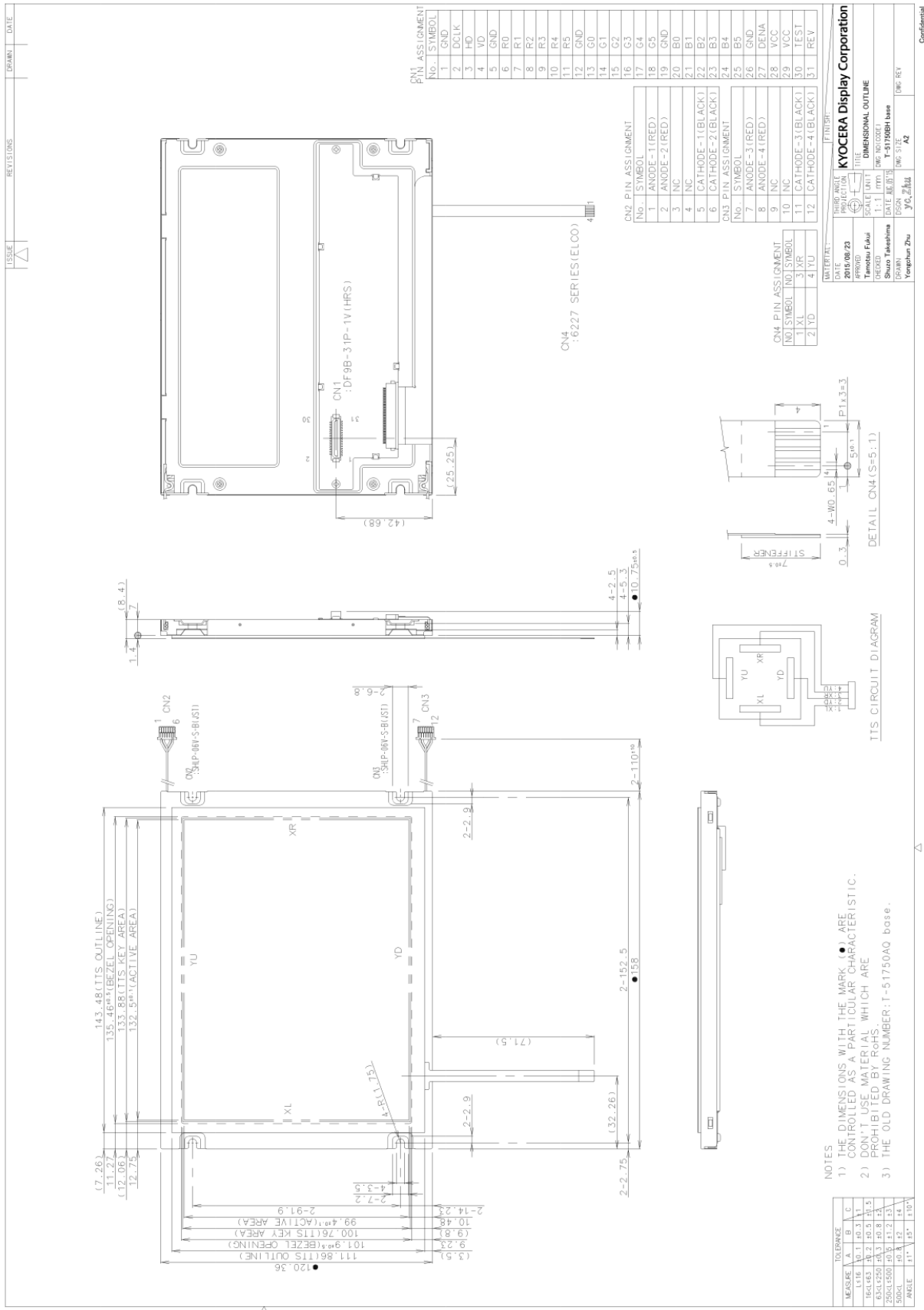

## 5. Block Diagram

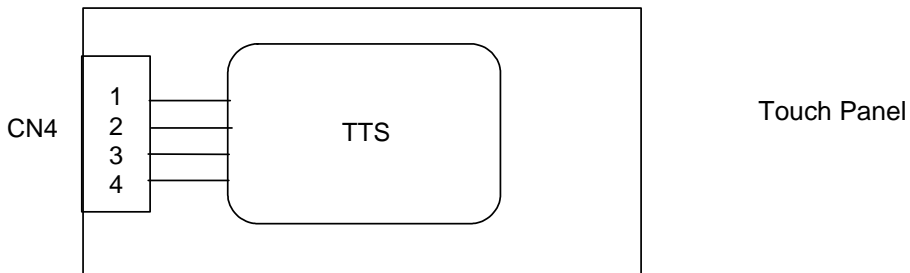
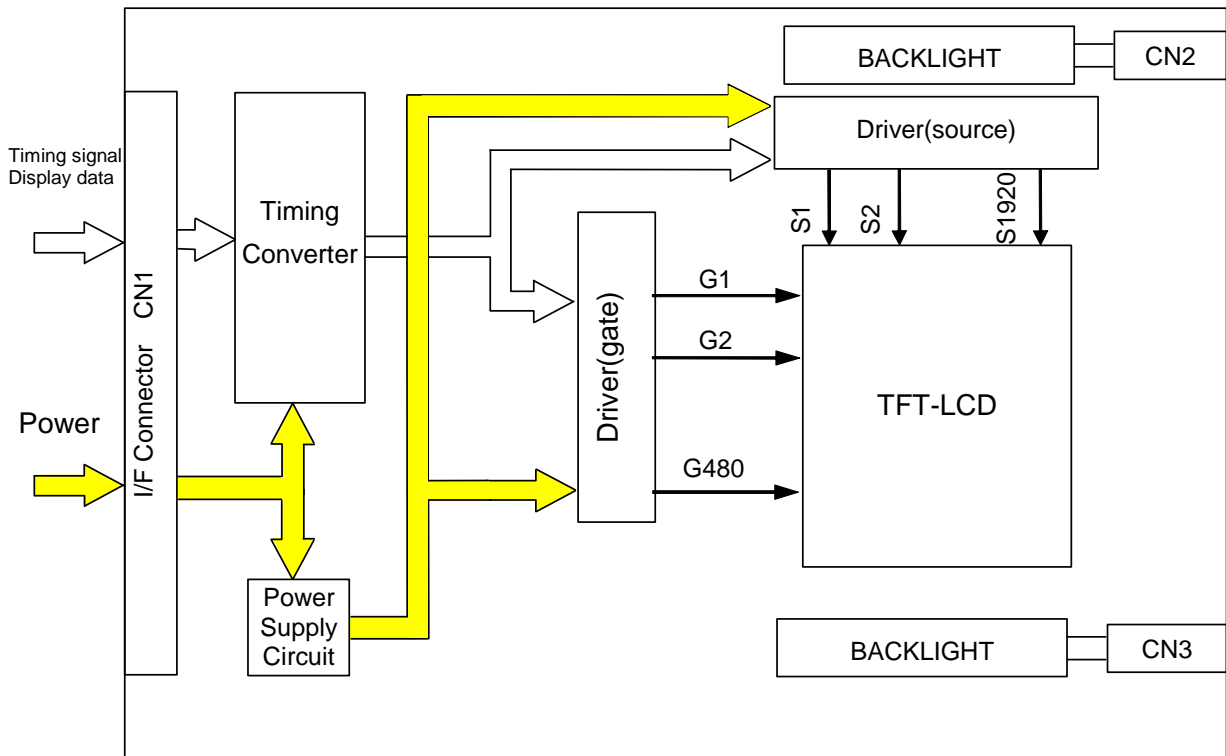

## 6. Pin assignment

### CN 1 (INTERFACE SIGNAL)

Used connector: DF9B-31P-1V (Hirose)

Corresponding connector: DF9B-31S-1V (Hirose)

| Pin No. | Symbol | Function  |
|---------|--------|---|
| 1       | GND    |   |
| 2       | DCLK   | Clock signal for sampling catch data signal                             |
| 3       | HD     | Horizontal sync signal  |
| 4       | VD     | Vertical sync signal  |
| 5       | GND    |   |
| 6       | R0     | Red data signal(LSB)  |
| 7       | R1     | Red data signal   |
| 8       | R2     | Red data signal   |
| 9       | R3     | Red data signal   |
| 10      | R4     | Red data signal   |
| 11      | R5     | Red data signal(MSB)  |
| 12      | GND    |   |
| 13      | G0     | Green data signal(LSB)  |
| 14      | G1     | Green data signal   |
| 15      | G2     | Green data signal   |
| 16      | G3     | Green data signal   |
| 17      | G4     | Green data signal   |
| 18      | G5     | Green data signal(MSB)  |
| 19      | GND    |   |
| 20      | B0     | Blue data signal(LSB)   |
| 21      | B1     | Blue data signal  |
| 22      | B2     | Blue data signal  |
| 23      | B3     | Blue data signal  |
| 24      | B4     | Blue data signal  |
| 25      | B5     | Blue data signal(MSB)   |
| 26      | GND    |   |
| 27      | DENA   | Data enable signal(to settle the viewing area)                          |
| 28      | VCC    | Power Supply (DC 3.3V or 5V)  |
| 29      | VCC    | Power Supply (DC 3.3V or 5V)  |
| 30      | TEST   | This pin should be open. Test signal output for only internal test use. |
| 31      | REV    | Reverse scan control. L = Normal, H = Reverse                           |

\*) The shielding case is connected with GND

### CN 2 Used connector: SHLP-06V-S-B(JST)

Corresponding connector: SM06-SHLS-TF(JST)

| Pin No. | Symbol           | Function             |
|---------|------------------|----------------------|
| 1       | ANODE-1(RED)     | LED Anode Terminal   |
| 2       | ANODE-2(RED)     | LED Anode Terminal   |
| 3       | NC               | Non-connection       |
| 4       | NC               | Non-connection       |
| 5       | CATHODE-1(BLACK) | LED Cathode Terminal |
| 6       | CATHODE-2(BLACK) | LED Cathode Terminal |

CN 3 Used connector: SHLP-06V-S-B(JST)

Corresponding connector: SM06-SHLS-TF(JST)

| Pin No. | Symbol           | Function             |
|---------|------------------|----------------------|
| 1       | ANODE-3(RED)     | LED Anode Terminal   |
| 2       | ANODE-4(RED)     | LED Anode Terminal   |
| 3       | NC               | Non-connection       |
| 4       | NC               | Non-connection       |
| 5       | CATHODE-3(BLACK) | LED Cathode Terminal |
| 6       | CATHODE-4(BLACK) | LED Cathode Terminal |

CN4 (Touch Panel)

Used FPC: P1.0mm, 4Pin, T=0.3mm

Corresponding connector: 6227 Series(ELCO)

| No. | Symbol | Functional Description |
|-----|--------|------------------------|
| 1   | XL     | X left side            |
| 2   | YD     | Y 6o`clock side        |
| 3   | XR     | X right side           |
| 4   | YU     | Y 12o`clock side       |

## 7. Electrical Specifications

### 7.1. Absolute Maximum Ratings

| Parameter              | Symbol | Conditions | Min. | Max. | Unit |
|------------------------|--------|------------|------|------|------|
| Supply Voltage for LCD | VCC    | -          | 0    | 5.5  | V    |
| Logic Input Voltage    | VI     | -          | -0.3 | 5.5  | V    |

### 7.2. DC characteristics

#### (1) TFT-LCD

Ambient Temperature : Ta = 25°C

| ITEM                                     | SYMBOL | MIN. | TYP. | MAX. | UNIT  | Remarks         |         |
|--|--------|------|------|------|-------|-----------------|---------|
| Power Supply Voltages for LCD<br>Note A) | VCC    | 3.0  | 3.3  | 3.6  | V     | for 3.3V system |         |
|  |        | 4.5  | 5.0  | 5.5  | V     | for 5V system   |         |
| Power Supply Currents for LCD<br>Note B) | ICC    | --   | 240  | --   | mA    | for 3.3V system |         |
|  |        | --   | 180  | --   | mA    | for 5V system   |         |
| Permissive input ripple Voltage          | VRP    | --   | --   | 100  | mVp-p | VCC=+3.3V       |         |
|  |        | --   | --   | 100  | mVp-p | VCC=+5.0V       |         |
| Logic Input Voltage                      | High   | VIH  | 2.4  | --   | 5.5   | V               | VCC=MAX |
|  | Low    | VIL  | --   | --   | 0.8   | V               | VCC=MIN |

[Note]

A) VCC-dip conditions:

- 1) When  $2.4\text{ V} \leq VCC < 3.0\text{ V}$  or  $4.5\text{V}$ ,  $t_d \leq 10\text{ ms}$
- 2) When  $VCC < 2.4\text{ V}$

VCC-dip conditions should also follow the power and signals sequence.

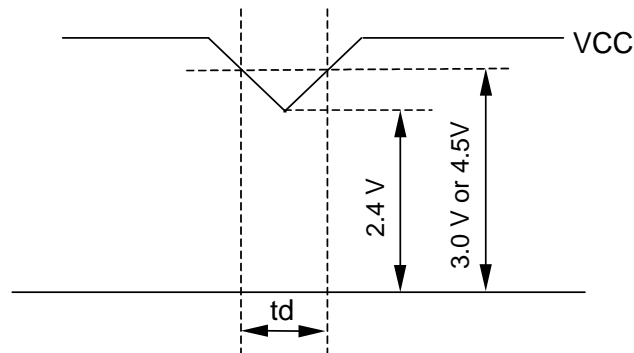

B) Typical current condition:

64- gray- bar-pattern

480 line mode

VCC = +3.3 V,  $f_H=31.5\text{kHz}$ ,  $f_V=60\text{Hz}$ ,  $f_{CLK}= 25\text{MHz}$

VCC = +5.0 V,  $f_H=31.5\text{kHz}$ ,  $f_V=60\text{Hz}$ ,  $f_{CLK}= 25\text{MHz}$



### 7.3.AC Characteristic

| ITEM                            |                        | SYMBOL    | MIN. | TYP. | MAX. | UNIT      |
|---------------------------------|------------------------|-----------|------|------|------|-----------|
| DCLK                            | Frequency              | $f_{CLK}$ | 20   | 25   | 30   | MHz       |
|                                 | Period                 | $t_{CLK}$ | 33.3 | 40   | 50   | ns        |
|                                 | Low Width              | $t_{WCL}$ | 10   | --   | --   | ns        |
|                                 | High Width             | $t_{WCH}$ | 10   | --   | --   | ns        |
| DATA<br>(R,G,B,DENA,<br>HD, VD) | Set up time            | $t_{DS}$  | 5    | --   | --   | ns        |
|                                 | Hold time              | $t_{DH}$  | 5    | --   | --   | ns        |
| DENA                            | Horizontal Active Time | $t_{HA}$  | 640  | 640  | 640  | $t_{CLK}$ |
|                                 | Horizontal Front Porch | $t_{HFP}$ | 0    | --   | --   | $t_{CLK}$ |
|                                 | Horizontal Back Porch  | $t_{HBP}$ | 7    | --   | --   | $t_{CLK}$ |
|                                 | Vertical Active Time   | $t_{VA}$  | 480  | 480  | 480  | $t_H$     |
|                                 | Vertical Front Porch   | $t_{VFP}$ | 1    | 20   | --   | $t_H$     |
|                                 | Vertical Back Porch    | $t_{VBP}$ | 8    | 20   | --   | $t_H$     |
| HD                              | Frequency              | $f_H$     | 27   | 31.5 | 38   | kHz       |
|                                 | Period                 | $t_H$     | 26.3 | 31.7 | 37.0 | $\mu s$   |
|                                 | Low Width              | $t_{WHL}$ | 5    | --   | --   | $t_{CLK}$ |
| VD                              | Frequency              | $f_V$     | 55   | 60   | 70   | Hz        |
|                                 | Period                 | $t_V$     | 14.3 | 16.7 | 18.2 | ms        |
|                                 | Low Width              | $t_{WVL}$ | 3    | --   | --   | $t_H$     |

[Note]

- 1) DATA is latched at fall edge of DCLK in this timing specification.
- 2) Polarities of HD and VD are negative in this specification.
- 3) DENA (Data Enable) should always be positive polarity as shown in the timing specification.
- 4) DCLK should appear during all invalid period, and HD should appear during invalid period of frame cycle.
- 5) Accepted only 640 data and 480 lines.
- 6) REV should be stable during operation.

7) Please consider the influence of the filter circuit which is placed in the Signal Input, DCLK and Data Bus, when designing the circuit. AC Characteristic spec is based on ideal signal driving.

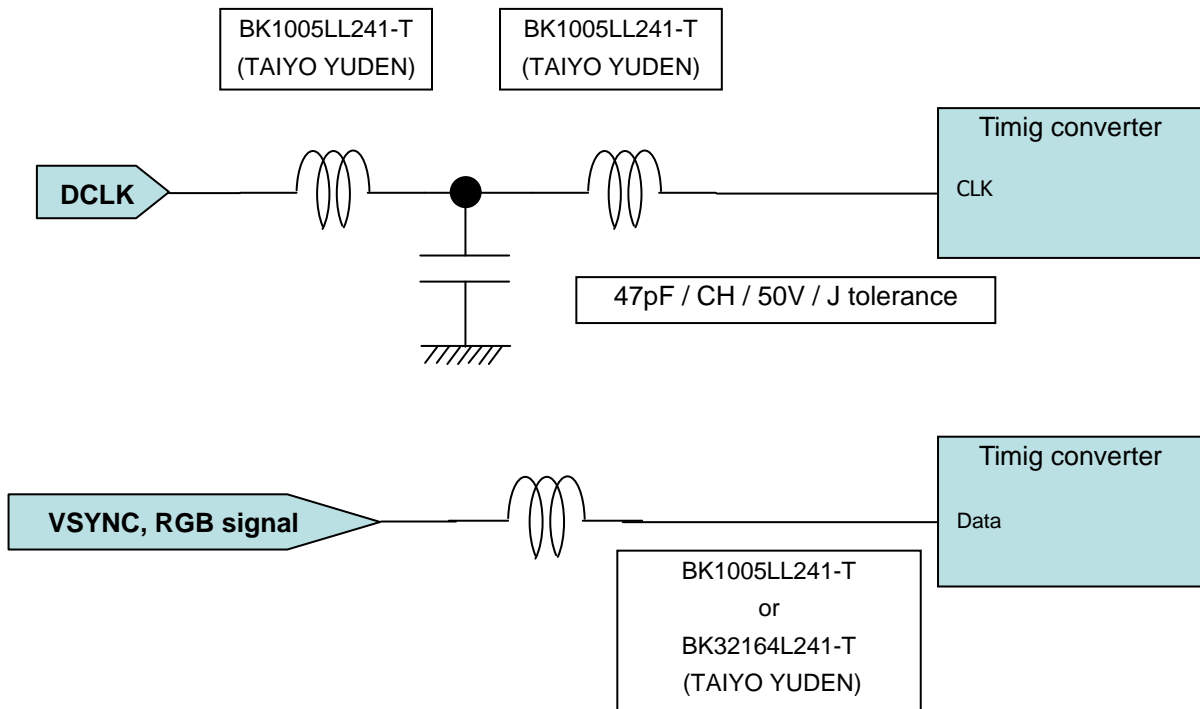

## 7.4. Timing Chart

### a. Pixel Timing Chart

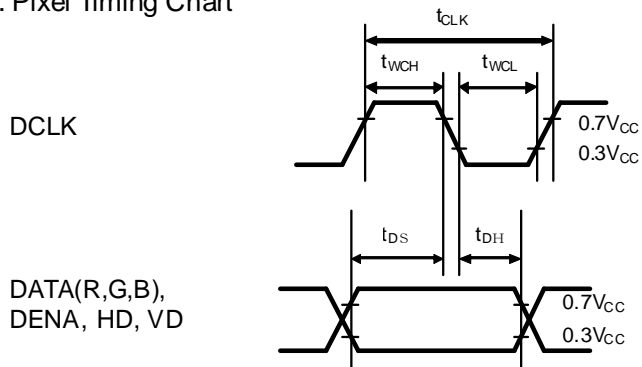

### b. Horizontal Timing Chart

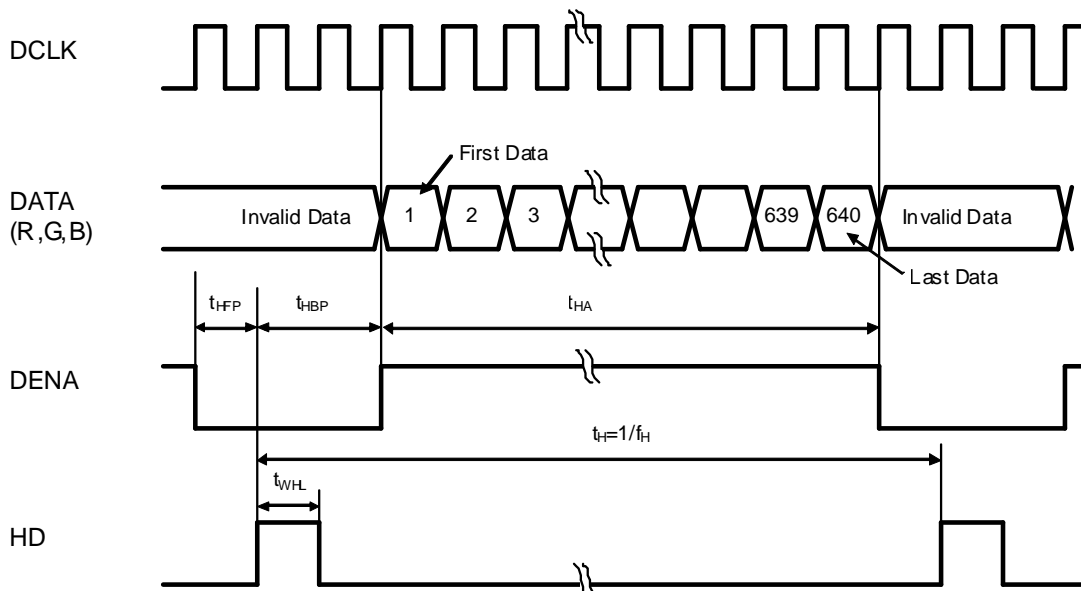

### c. Vertical Timing Chart

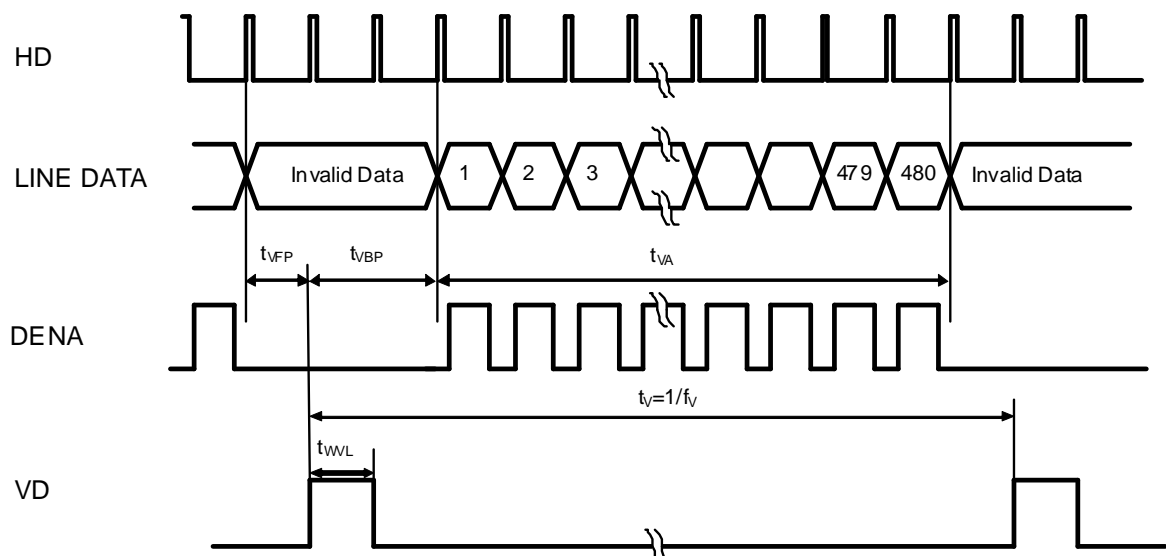

7.5. Power and signals sequence:

- $t1 \leq 10 \text{ ms}$
- $0 < t2 \leq 50 \text{ ms}$
- $0 < t3 \leq 50 \text{ ms}$
- $0 < t4 \leq 50 \text{ ms}$
- $500 \text{ ms} < t5$
- $200 \text{ ms} < t6$
- $0 \leq t7$

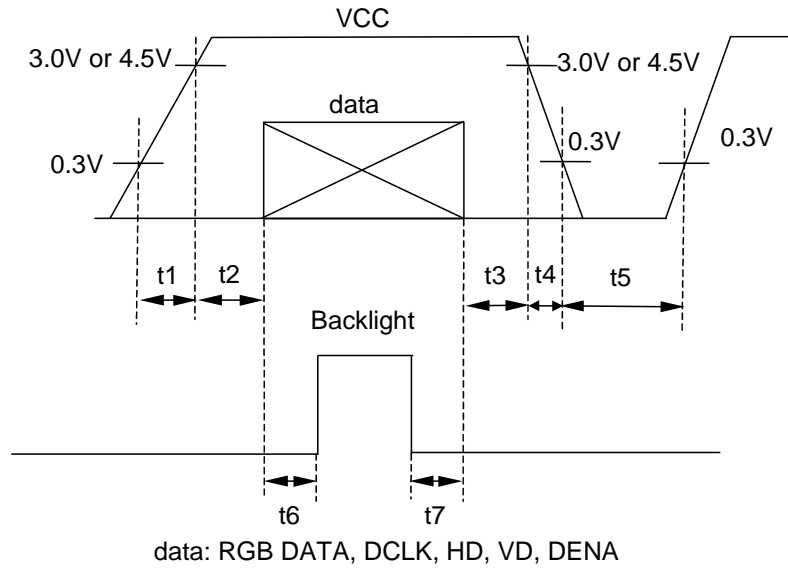

7.6. Pixel Alignment

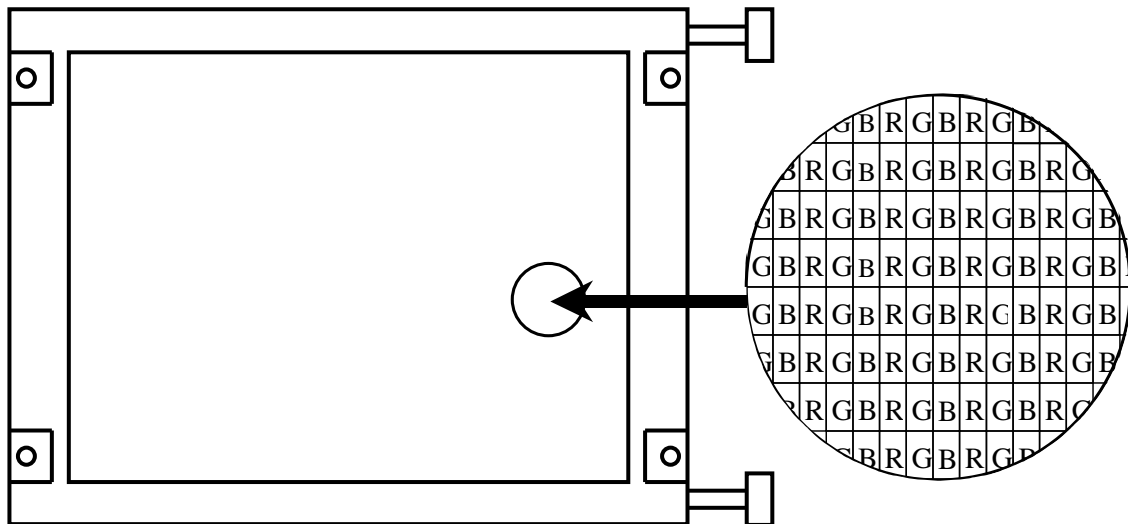

### 7.7.Color Data Assignment

| COLOR       | INPUT DATA | R DATA |    |    |     |    |    | G DATA |    |    |     |    |    | B DATA |    |    |     |    |    |
|-------------|------------|--------|----|----|-----|----|----|--------|----|----|-----|----|----|--------|----|----|-----|----|----|
|             |            | MSB    |    |    | LSB |    |    | MSB    |    |    | LSB |    |    | MSB    |    |    | LSB |    |    |
|             |            | R5     | R4 | R3 | R2  | R1 | R0 | G5     | G4 | G3 | G2  | G1 | G0 | B5     | B4 | B3 | B2  | B1 | B0 |
| BASIC COLOR | BLACK      | 0      | 0  | 0  | 0   | 0  | 0  | 0      | 0  | 0  | 0   | 0  | 0  | 0      | 0  | 0  | 0   | 0  | 0  |
|             | RED (63)   | 1      | 1  | 1  | 1   | 1  | 1  | 0      | 0  | 0  | 0   | 0  | 0  | 0      | 0  | 0  | 0   | 0  | 0  |
|             | GREEN (63) | 0      | 0  | 0  | 0   | 0  | 0  | 1      | 1  | 1  | 1   | 1  | 1  | 0      | 0  | 0  | 0   | 0  | 0  |
|             | BLUE (63)  | 0      | 0  | 0  | 0   | 0  | 0  | 0      | 0  | 0  | 0   | 0  | 0  | 1      | 1  | 1  | 1   | 1  | 1  |
|             | CYAN       | 0      | 0  | 0  | 0   | 0  | 0  | 1      | 1  | 1  | 1   | 1  | 1  | 1      | 1  | 1  | 1   | 1  | 1  |
|             | MAGENTA    | 1      | 1  | 1  | 1   | 1  | 1  | 0      | 0  | 0  | 0   | 0  | 0  | 1      | 1  | 1  | 1   | 1  | 1  |
|             | YELLOW     | 1      | 1  | 1  | 1   | 1  | 1  | 1      | 1  | 1  | 1   | 1  | 1  | 0      | 0  | 0  | 0   | 0  | 0  |
|             | WHITE      | 1      | 1  | 1  | 1   | 1  | 1  | 1      | 1  | 1  | 1   | 1  | 1  | 1      | 1  | 1  | 1   | 1  | 1  |
| RED         | RED (0)    | 0      | 0  | 0  | 0   | 0  | 0  | 0      | 0  | 0  | 0   | 0  | 0  | 0      | 0  | 0  | 0   | 0  | 0  |
|             | RED (1)    | 0      | 0  | 0  | 0   | 0  | 1  | 0      | 0  | 0  | 0   | 0  | 0  | 0      | 0  | 0  | 0   | 0  | 0  |
|             | RED (2)    | 0      | 0  | 0  | 0   | 1  | 0  | 0      | 0  | 0  | 0   | 0  | 0  | 0      | 0  | 0  | 0   | 0  | 0  |
|             |            |        |    |    |     |    |    |        |    |    |     |    |    |        |    |    |     |    |    |
|             |            |        |    |    |     |    |    |        |    |    |     |    |    |        |    |    |     |    |    |
|             | RED (62)   | 1      | 1  | 1  | 1   | 1  | 0  | 0      | 0  | 0  | 0   | 0  | 0  | 0      | 0  | 0  | 0   | 0  | 0  |
|             | RED (63)   | 1      | 1  | 1  | 1   | 1  | 1  | 0      | 0  | 0  | 0   | 0  | 0  | 0      | 0  | 0  | 0   | 0  | 0  |
| GREEN       | GREEN (0)  | 0      | 0  | 0  | 0   | 0  | 0  | 0      | 0  | 0  | 0   | 0  | 0  | 0      | 0  | 0  | 0   | 0  | 0  |
|             | GREEN (1)  | 0      | 0  | 0  | 0   | 0  | 0  | 0      | 0  | 0  | 0   | 0  | 1  | 0      | 0  | 0  | 0   | 0  | 0  |
|             | GREEN (2)  | 0      | 0  | 0  | 0   | 0  | 0  | 0      | 0  | 0  | 0   | 1  | 0  | 0      | 0  | 0  | 0   | 0  | 0  |
|             |            |        |    |    |     |    |    |        |    |    |     |    |    |        |    |    |     |    |    |
|             |            |        |    |    |     |    |    |        |    |    |     |    |    |        |    |    |     |    |    |
|             | GREEN (62) | 0      | 0  | 0  | 0   | 0  | 0  | 1      | 1  | 1  | 1   | 1  | 0  | 0      | 0  | 0  | 0   | 0  | 0  |
|             | GREEN (63) | 0      | 0  | 0  | 0   | 0  | 0  | 1      | 1  | 1  | 1   | 1  | 1  | 0      | 0  | 0  | 0   | 0  | 0  |
| BLUE        | BLUE (0)   | 0      | 0  | 0  | 0   | 0  | 0  | 0      | 0  | 0  | 0   | 0  | 0  | 0      | 0  | 0  | 0   | 0  | 0  |
|             | BLUE (1)   | 0      | 0  | 0  | 0   | 0  | 0  | 0      | 0  | 0  | 0   | 0  | 0  | 0      | 0  | 0  | 0   | 0  | 1  |
|             | BLUE (2)   | 0      | 0  | 0  | 0   | 0  | 0  | 0      | 0  | 0  | 0   | 0  | 0  | 0      | 0  | 0  | 0   | 1  | 0  |
|             |            |        |    |    |     |    |    |        |    |    |     |    |    |        |    |    |     |    |    |
|             |            |        |    |    |     |    |    |        |    |    |     |    |    |        |    |    |     |    |    |
|             | BLUE (62)  | 0      | 0  | 0  | 0   | 0  | 0  | 0      | 0  | 0  | 0   | 0  | 0  | 1      | 1  | 1  | 1   | 1  | 0  |
|             | BLUE (63)  | 0      | 0  | 0  | 0   | 0  | 0  | 0      | 0  | 0  | 0   | 0  | 0  | 1      | 1  | 1  | 1   | 1  | 1  |

[Note]

- 1) Definition of gray scale  
Color (n) --- n indicates gray scale level.  
Higher n means brighter level.
- 2) Data 1:High, 0: Low

## 7.8. Inverted Scan Capability

This module has the capability of inverting scan direction by signaling from controller.

Note that scan direction cannot be changed during operation.

The following figure shows the relation between the display position and the scan direction.

### DISPLAY POSITION

Normal scan: REV = "L"

|           |           |     |           |     |            |            |
|-----------|-----------|-----|-----------|-----|------------|------------|
| D( 1, 1)  | D( 2, 1)  | --- | D( X, 1)  | --- | D(639, 1)  | D(640, 1)  |
| D( 1, 2)  | D( 2, 2)  | --- | D( X, 2)  | --- | D(639, 2)  | D(640, 2)  |
| ⋮         | ⋮         | +   | +         | +   | ⋮          | ⋮          |
| D( 1, Y)  | D( 2, Y)  | --- | D( X, Y)  | --- | D(639, Y)  | D(640, Y)  |
| ⋮         | ⋮         | +   | +         | +   | ⋮          | ⋮          |
| D( 1,479) | D( 2,479) | --- | D( X,479) | --- | D(639,479) | D(640,479) |
| D( 1,480) | D( 2,480) | --- | D( X,480) | --- | D(639,480) | D(640,480) |

Reverse scan: REV = "H"

|            |            |     |           |     |           |           |
|------------|------------|-----|-----------|-----|-----------|-----------|
| D(640,480) | D(639,480) | --- | D( X,480) | --- | D( 2,480) | D( 1,480) |
| D(640,479) | D(639,479) | --- | D( X,479) | --- | D( 2,479) | D( 1,479) |
| ⋮          | ⋮          | +   | +         | +   | ⋮         | ⋮         |
| D(640, Y)  | D(639, Y)  | --- | D( X, Y)  | --- | D( 2, Y)  | D( 1, Y)  |
| ⋮          | ⋮          | +   | +         | +   | ⋮         | ⋮         |
| D(640, 2)  | D(639, 2)  | --- | D( X, 2)  | --- | D( 2, 2)  | D( 1, 2)  |
| D(640, 1)  | D(639, 1)  | --- | D( X, 1)  | --- | D( 2, 1)  | D( 1, 1)  |

The following drawing shows the relationship between the viewing direction and the scan direction.

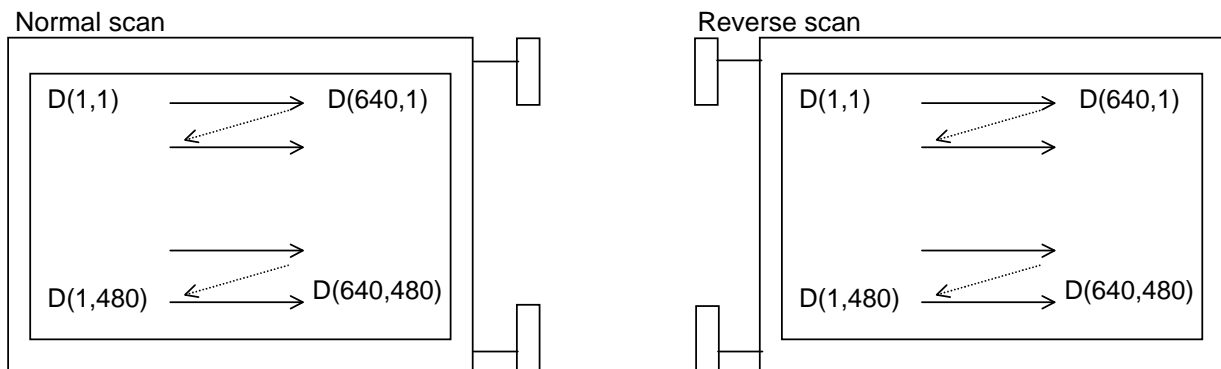

## 7.9. Lighting Specifications

### 7.9.1. Absolute Maximum Ratings

Ta=25°C

| Parameter                 | Symbol         | Conditions | Min. | Typ. | Max. | Units |
|---------------------------|----------------|------------|------|------|------|-------|
| Foward Current            | I <sub>F</sub> | Note 2     | -    | -    | 40   | mA    |
| Allowable Reverse Current | I <sub>R</sub> | -          | -    | -    | 85   | mA    |
| LED Power Dissipation     | P <sub>D</sub> | -          | -    | -    | 1.28 | W     |

Note 1 : Tiis value is for each 1 line.

Note 2 : Refer to the foward current derating curve.

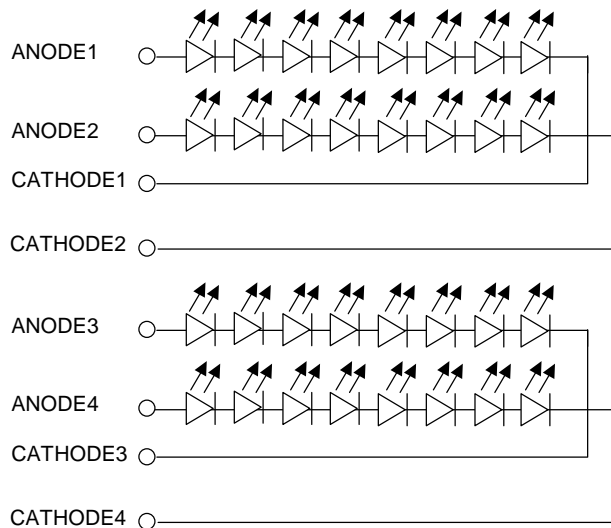
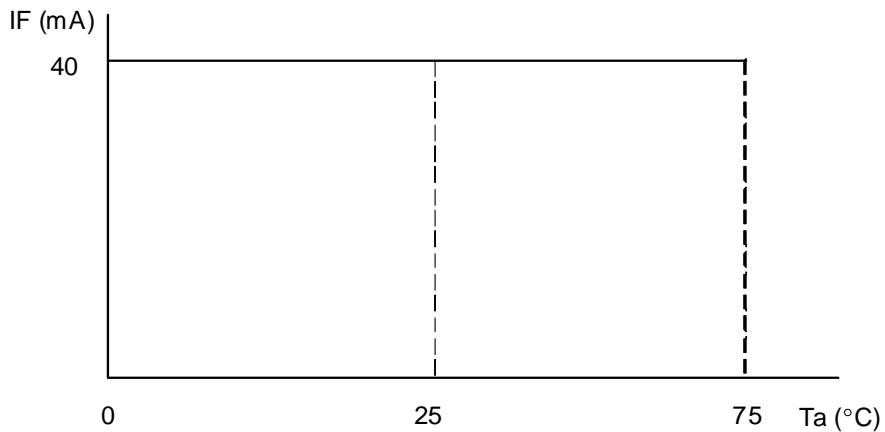

### 7.9.2. Operating Characteristics

Ta=25°C

| Parameter      | Symbol         | Conditions                    | Min. | Typ. | Max. | Units |
|----------------|----------------|-------------------------------|------|------|------|-------|
| Foward Voltage | V <sub>F</sub> | I <sub>F</sub> =35mA / 1 line | -    | 26.4 | 31.2 | V     |

## 7.10. Touch Panel Specifications

### 7.10.1. Touch Panel Characteristics

Ta=-10~60°C

| Parameter                     |       | Min. | Typ. | Max. | Units | Conditions    |
|-------------------------------|-------|------|------|------|-------|---------------|
| Max Voltage                   |       | -    | -    | 5.5  | V     |               |
| Resistor between<br>Terminals | XL-LR | 300  | -    | 1000 | Ω     |               |
|                               | YU-UD | 100  |      | 500  | Ω     |               |
| Line Linearity                |       | -    | -    | ±1.5 | %     | Initial Value |
| Insulation Resistance         |       | 10   | -    | -    | MΩ    | At DC25V      |
| Operation Force               |       | 10   | -    | 100  | g     | Initial Value |



## 8. Optical Specifications

| Item                     | Symbol | Conditions   |        |    | Standard Value |      |      | Unit              | Method of Measure | Remark    |  |
|--------------------------|--------|--------------|--------|----|----------------|------|------|-------------------|-------------------|-----------|--|
|                          |        | $\theta$     | $\phi$ | C  | Min.           | Typ. | Max. |                   |                   |           |  |
| Brightness               | B      | 0°           | 0°     | /  | -              | 800  | -    | cd/m <sup>2</sup> | (Fig.3-1)         | Note3-1   |  |
| Contrast                 | CR     | Best Viewing |        |    | 400            | 800  | -    | -                 |                   |           |  |
| Color Coordinates        | Red    | Rx           | 0°     | 0° | /              | -    | 0.60 | -                 |                   | -         |  |
|                          |        | Ry           | 0°     | 0° | /              | -    | 0.35 | -                 |                   | -         |  |
|                          | Green  | Gx           | 0°     | 0° | /              | -    | 0.33 | -                 |                   | -         |  |
|                          |        | Gy           | 0°     | 0° | /              | -    | 0.59 | -                 |                   | -         |  |
|                          | Blue   | Bx           | 0°     | 0° | /              | -    | 0.16 | -                 |                   | -         |  |
|                          |        | By           | 0°     | 0° | /              | -    | 0.13 | -                 |                   | -         |  |
|                          | White  | Wx           | 0°     | 0° | /              | -    | 0.32 | -                 |                   | -         |  |
| Wy                       |        | 0°           | 0°     | /  | -              | 0.35 | -    | -                 |                   |           |  |
| Brightness Uniformity    | -      | 0°           | 0°     | /  | 0.7            | -    | -    | -                 | (Fig.3-2)         |           |  |
| Vertical Viewing Angle   | Up     | $\theta_U$   | -      | 0° | $\geq 10$      | -    | 50   | -                 | Degree            | (Fig.3-3) |  |
|                          | Down   | $\theta_D$   | -      | 0° | $\geq 10$      | -    | 70   | -                 | Degree            |           |  |
| Horizontal Viewing Angle | Left   | $\phi_L$     | 0°     | -  | $\geq 10$      | -    | 80   | -                 | Degree            |           |  |
|                          | Right  | $\phi_R$     | 0°     | -  | $\geq 10$      | -    | 80   | -                 | Degree            |           |  |
| Response Time            | Rise   | $\tau_r$     | 0°     | 0° | /              | -    | 15   | -                 | ms                | (Fig.3-4) |  |
|                          | Decay  | $\tau_d$     | 0°     | 0° | /              | -    | 16   | -                 | ms                |           |  |
| Haze                     | H      | /            |        |    | -              | 9    | -    | %                 |                   |           |  |

Note3-1: Under the condition of maximum brightness.

- ◆ Conditions for Measuring
  - ◇ Environment: Dark room with no light or close to no light.
  - ◇ Temperature: 25±5°C
  - ◇ Humidity: 40~70%RH
- ◆ Optimal viewing angle (The angle with best contrast)

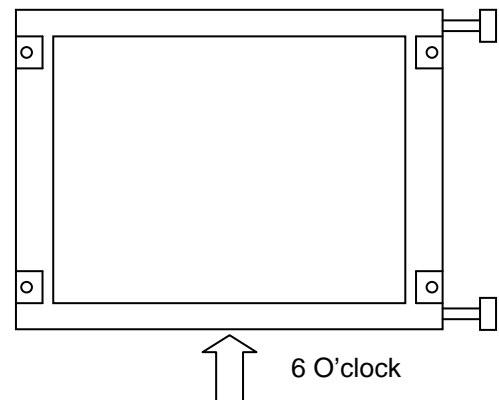

(Fig.3-1)

◆ Method of Brightness Measurement

(1) Measuring Device

TOPCON BM-5, Measuring Field: 1°

(2) Measuring Point

Center of Display  $\theta=0^\circ, \phi=0^\circ$

On condition  $\theta$ : A vertical angle from measuring direction to perpendicular.

$\phi$ : A horizontal angle from measuring direction to perpendicular.

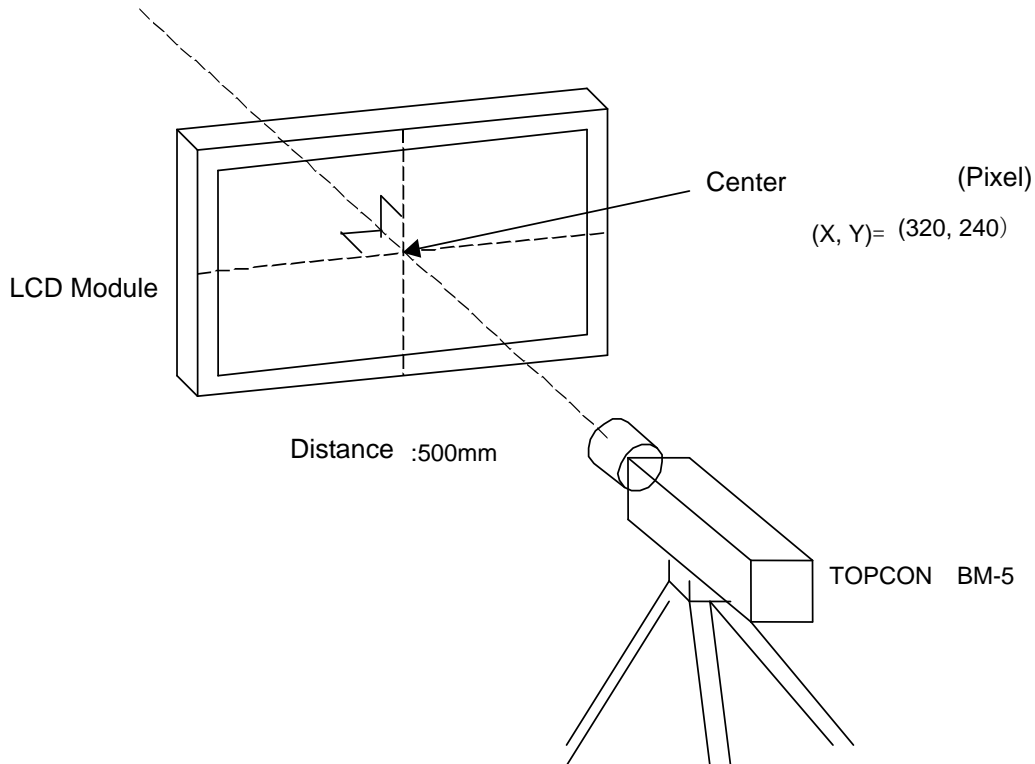

(3) Method of Measuring

Apply signal voltage (displayed in white) to maximize brightness and measure brightness B ( $\text{cd}/\text{m}^2$ ).

The distance between BM-5's front lens to surface panel is 500mm.

Measured after backlight has been lit for more than 30 minutes.

◆ Method of Contrast Measurement

(1) Measuring Device

TOPCON BM-5, Measuring Field: 1°

(2) Measuring Point

Center of display: same as Method of Brightness Measurement

(3) Method of Measuring

- Set LCD module to  $\theta=0^\circ, \phi=0^\circ$ .
- Change signal voltage to measure maximum brightness Y1 and minimum brightness Y2.
- Contrast is derived from  $CR=Y1/Y2$ .

(Fig.3-2)

◆ Definition of Brightness Uniformity

Definition is calculated from the 5 points (S0-S4) on the diagram below.

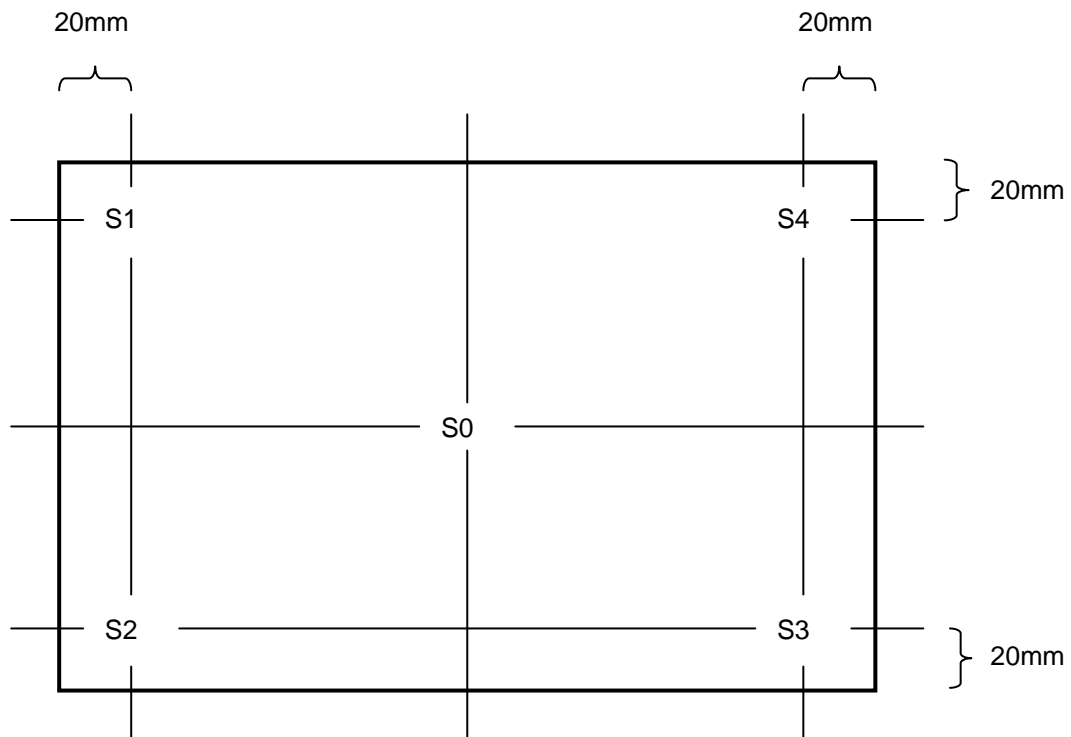

$$\text{Standard Value of Brightness Uniformity} = \frac{\text{Minimum Value of S1-S4}}{S0}$$

(Fig.3-3)

◆ Method of Viewing Angle Measurement

(1) Measuring Device

ELDIM: EZ CONTRAST, Measuring Field: 1°

(2) Measuring Point

Center of display : Same as Method of Brightness Measurement

(3) Angle of Measuring

$\theta$ : An angle vertical to perpendicular line from the viewing direction.

$\phi$ : An angle horizontal to perpendicular from the viewing direction.

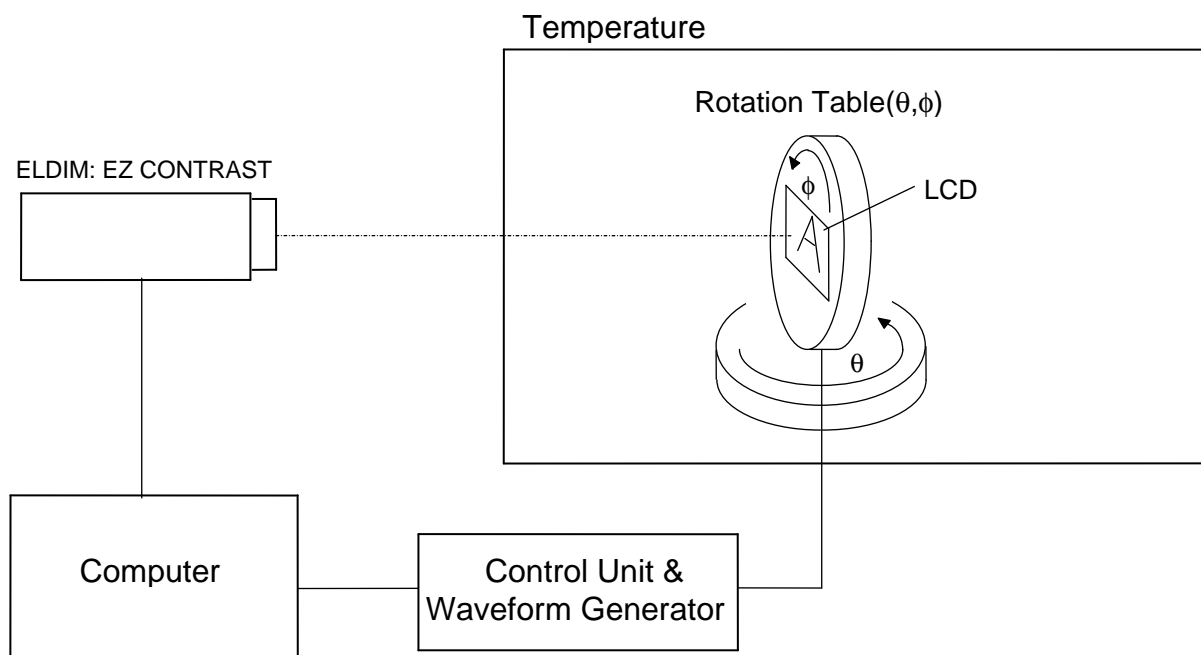

(4) Method of Measuring

Set the module on the rotation table and measure a vertical axis direction in the state that fixed  $\phi = 0$  degrees horizontal axis direction to  $\theta = 90$  degrees.

(Viewing angle is measured automatically by EZ CONTRAST)

(Fig.3-4)

◆ Measuring Response Time

(1) Measuring Device

TOPCON BM-5, Measuring Field: 1°

Tektronix Digital Oscilloscope

(2) Measuring Point

Center of display, same as Method of Brightness Measurement

(3) Method of Measuring

- Set LCD panel to  $\theta=0^\circ$ , and  $\phi=0^\circ$ .
- Input white  $\rightarrow$  black  $\rightarrow$  white to display by switching signal voltage.
- If the luminance is 0% and 100% immediately before the change of signal voltage, then  $\tau_r$  is optical response time during the change from 90% to 10% immediately after rise of signal voltage, and  $\tau_d$  is optical response time during the change from 10% to 90% immediately after decay of signal voltage.

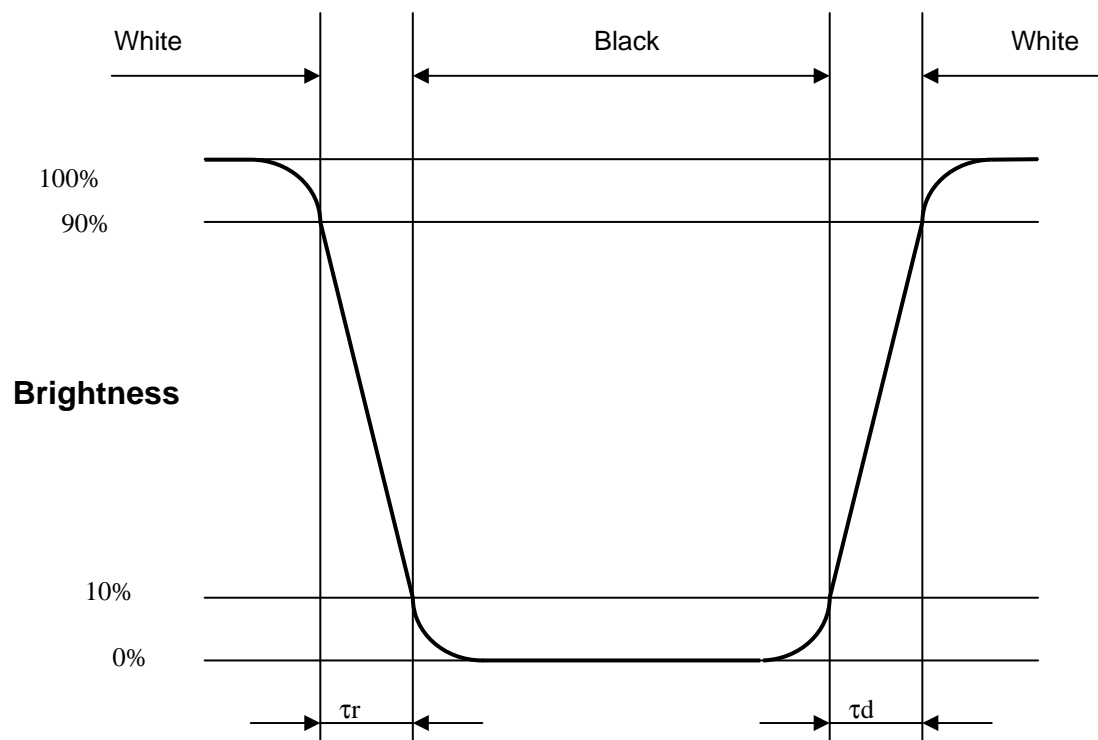

## 9. Test

No abnormal function and appearance are found after the following tests.

Conditions: Unless otherwise specified, tests will be conducted under the following condition.

Temperature:  $20\pm 5^{\circ}\text{C}$

Humidity :  $65\pm 5\% \text{RH}$

tests will be not conducted under functioning state.

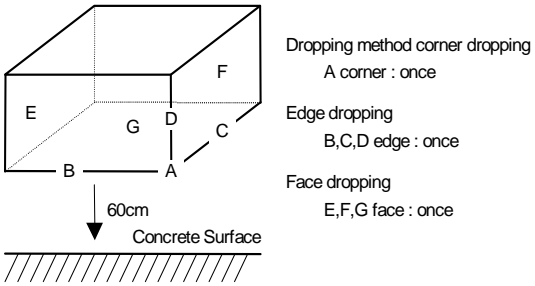
| No. | Parameter                  | Conditions   | Notes |
|-----|----------------------------|--|-------|
| 1   | High Temperature Operating | 70°C, 96hrs (operation state)  |       |
| 2   | High Temperature Storage   | 70°C, 96hrs  | 2     |
| 3   | Low Temperature Storage    | -20°C, 96hrs   | 1,2   |
| 4   | Damp Proof Test            | 40°C, 90~95%RH, 96hrs  | 1,2   |
| 5   | Vibration Test             | Frequency:10-57Hz/Vibration width(one side):0.75mm<br>:58-500Hz/Gravity:9.8m/s <sup>2</sup><br>Sweep time:11minutes<br>Test period:3hrs for each direction of X,Y,Z                                    | 3     |
| 6   | Shock                      | Shock level:490m/s <sup>2</sup><br>Waveform:half sinusoidal wave, 11ms<br>Number of shocks :<br>One shock input in each direction of three mutually perpendicular axis for a total of six shock inputs |       |
| 7   | Shock Test                 | To be measured after dropping from 60cm high on the concrete surface in packing state.<br><br>                     |       |

Note 1: No dew condensation to be observed.

Note 2: The function test shall be conducted after 4 hours storage at the normal Temperature and humidity after removed from the test chamber.

Note 3: Vibration test will be conducted to the product itself without putting it in a container.

## 10. Appearance Standards

### 10.1. Inspection conditions

The LCD shall be inspected under 40W white fluorescent light.

The distance between the eyes and the sample shall be more than 30cm.

All directions for inspecting the sample should be within 45° against perpendicular line.

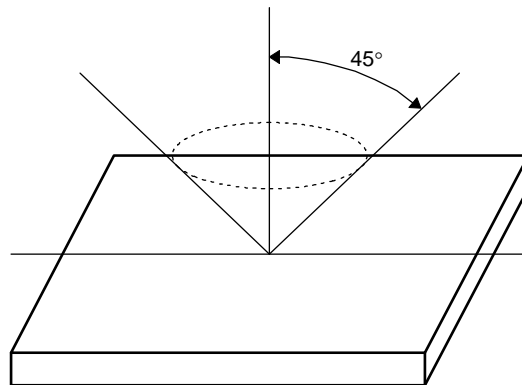

### 10.2. Definition of applicable Zones

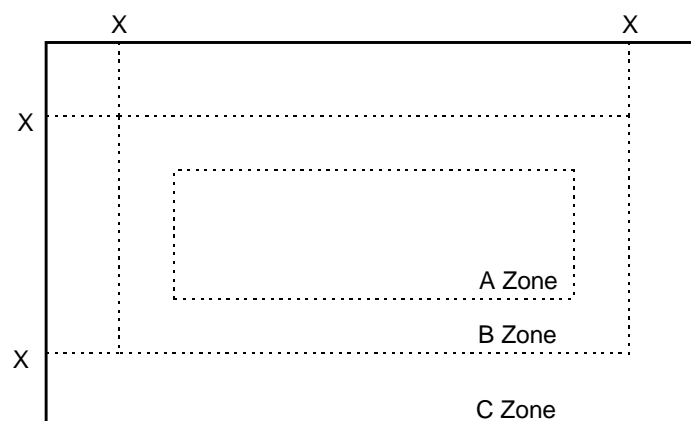

X : Maximum Seal Line

A Zone : Active display area

B Zone : Out of active display area up to viewing area

C Zone : Rest parts

A Zone + B Zone = Viewing area

10.3.Standards

| No.             | Parameter                   | Criteria  |      |   |                   |  |  |   |   |   |                |       |  |  |  |                 |                 |   |  |   |          |          |   |  |   |   |          |                         |  |   |
|-----------------|-----------------------------|---|------|---|-------------------|--|--|---|---|---|----------------|-------|--|--|--|-----------------|-----------------|---|--|---|----------|----------|---|--|---|---|----------|-------------------------|--|---|
| 1               | Polarizer Scratches         | <table border="1"> <thead> <tr> <th colspan="2" rowspan="2">Zone</th> <th colspan="3">Acceptable Number</th> </tr> <tr> <th>A</th> <th>B</th> <th>C</th> </tr> </thead> <tbody> <tr> <td>X(mm)</td> <td>Y(mm)</td> <td></td> <td></td> <td></td> </tr> <tr> <td>L ≤ 15</td> <td>0.01 &lt; W ≤ 0.05</td> <td>4</td> <td></td> <td>*</td> </tr> <tr> <td>L &gt; 15</td> <td>W &gt; 0.01</td> <td>0</td> <td></td> <td>*</td> </tr> <tr> <td>-</td> <td>W &gt; 0.05</td> <td>0</td> <td></td> <td>*</td> </tr> </tbody> </table> <p>X : Length, Y : Width * : Disregard</p>              | Zone |   | Acceptable Number |  |  | A | B | C | X(mm)          | Y(mm) |  |  |  | L ≤ 15          | 0.01 < W ≤ 0.05 | 4 |  | * | L > 15   | W > 0.01 | 0 |  | * | - | W > 0.05 | 0                       |  | * |
| Zone            |                             | Acceptable Number   |      |   |                   |  |  |   |   |   |                |       |  |  |  |                 |                 |   |  |   |          |          |   |  |   |   |          |                         |  |   |
|                 |                             | A   | B    | C |                   |  |  |   |   |   |                |       |  |  |  |                 |                 |   |  |   |          |          |   |  |   |   |          |                         |  |   |
| X(mm)           | Y(mm)                       |   |      |   |                   |  |  |   |   |   |                |       |  |  |  |                 |                 |   |  |   |          |          |   |  |   |   |          |                         |  |   |
| L ≤ 15          | 0.01 < W ≤ 0.05             | 4   |      | * |                   |  |  |   |   |   |                |       |  |  |  |                 |                 |   |  |   |          |          |   |  |   |   |          |                         |  |   |
| L > 15          | W > 0.01                    | 0   |      | * |                   |  |  |   |   |   |                |       |  |  |  |                 |                 |   |  |   |          |          |   |  |   |   |          |                         |  |   |
| -               | W > 0.05                    | 0   |      | * |                   |  |  |   |   |   |                |       |  |  |  |                 |                 |   |  |   |          |          |   |  |   |   |          |                         |  |   |
| 2               | DENT                        | <table border="1"> <thead> <tr> <th colspan="2" rowspan="2">Zone</th> <th colspan="3">Acceptable Number</th> </tr> <tr> <th>A</th> <th>B</th> <th>C</th> </tr> </thead> <tbody> <tr> <td colspan="2">Dimension (mm)</td> <td></td> <td></td> <td></td> </tr> <tr> <td colspan="2">0.30 &lt; D ≤ 0.50</td> <td>4</td> <td></td> <td>*</td> </tr> <tr> <td colspan="2">0.50 &lt; D</td> <td>0</td> <td></td> <td>*</td> </tr> </tbody> </table> <p>D : Average Diameter = (long+short)/2 * : Disregard</p>  | Zone |   | Acceptable Number |  |  | A | B | C | Dimension (mm) |       |  |  |  | 0.30 < D ≤ 0.50 |                 | 4 |  | * | 0.50 < D |          | 0 |  | * |   |          |                         |  |   |
| Zone            |                             | Acceptable Number   |      |   |                   |  |  |   |   |   |                |       |  |  |  |                 |                 |   |  |   |          |          |   |  |   |   |          |                         |  |   |
|                 |                             | A   | B    | C |                   |  |  |   |   |   |                |       |  |  |  |                 |                 |   |  |   |          |          |   |  |   |   |          |                         |  |   |
| Dimension (mm)  |                             |   |      |   |                   |  |  |   |   |   |                |       |  |  |  |                 |                 |   |  |   |          |          |   |  |   |   |          |                         |  |   |
| 0.30 < D ≤ 0.50 |                             | 4   |      | * |                   |  |  |   |   |   |                |       |  |  |  |                 |                 |   |  |   |          |          |   |  |   |   |          |                         |  |   |
| 0.50 < D        |                             | 0   |      | * |                   |  |  |   |   |   |                |       |  |  |  |                 |                 |   |  |   |          |          |   |  |   |   |          |                         |  |   |
| 3               | BLACK and WHITE SPOT BUBBLE | <table border="1"> <thead> <tr> <th colspan="2" rowspan="2">Zone</th> <th colspan="3">Acceptable Number</th> </tr> <tr> <th>A</th> <th>B</th> <th>C</th> </tr> </thead> <tbody> <tr> <td colspan="2">Dimension (mm)</td> <td></td> <td></td> <td></td> </tr> <tr> <td colspan="2">0.30 &lt; D ≤ 0.50</td> <td>5</td> <td></td> <td>*</td> </tr> <tr> <td colspan="2">0.50 &lt; D</td> <td>0</td> <td></td> <td>*</td> </tr> </tbody> </table>   | Zone |   | Acceptable Number |  |  | A | B | C | Dimension (mm) |       |  |  |  | 0.30 < D ≤ 0.50 |                 | 5 |  | * | 0.50 < D |          | 0 |  | * |   |          |                         |  |   |
| Zone            |                             | Acceptable Number   |      |   |                   |  |  |   |   |   |                |       |  |  |  |                 |                 |   |  |   |          |          |   |  |   |   |          |                         |  |   |
|                 |                             | A   | B    | C |                   |  |  |   |   |   |                |       |  |  |  |                 |                 |   |  |   |          |          |   |  |   |   |          |                         |  |   |
| Dimension (mm)  |                             |   |      |   |                   |  |  |   |   |   |                |       |  |  |  |                 |                 |   |  |   |          |          |   |  |   |   |          |                         |  |   |
| 0.30 < D ≤ 0.50 |                             | 5   |      | * |                   |  |  |   |   |   |                |       |  |  |  |                 |                 |   |  |   |          |          |   |  |   |   |          |                         |  |   |
| 0.50 < D        |                             | 0   |      | * |                   |  |  |   |   |   |                |       |  |  |  |                 |                 |   |  |   |          |          |   |  |   |   |          |                         |  |   |
| 4               | LINT                        | <table border="1"> <thead> <tr> <th colspan="2" rowspan="2">Zone</th> <th colspan="3">Acceptable Number</th> </tr> <tr> <th>A</th> <th>B</th> <th>C</th> </tr> </thead> <tbody> <tr> <td>X(mm)</td> <td>Y(mm)</td> <td></td> <td></td> <td></td> </tr> <tr> <td>L ≤ 3.0</td> <td>W ≤ 0.15</td> <td>4</td> <td></td> <td>*</td> </tr> <tr> <td>L &gt; 3.0</td> <td>W ≤ 0.15</td> <td>0</td> <td></td> <td>*</td> </tr> <tr> <td>-</td> <td>W &gt; 0.15</td> <td colspan="2">According to BLACK SPOT</td> <td>*</td> </tr> </tbody> </table> <p>X : Length, Y : Width * : Disregard</p> | Zone |   | Acceptable Number |  |  | A | B | C | X(mm)          | Y(mm) |  |  |  | L ≤ 3.0         | W ≤ 0.15        | 4 |  | * | L > 3.0  | W ≤ 0.15 | 0 |  | * | - | W > 0.15 | According to BLACK SPOT |  | * |
| Zone            |                             | Acceptable Number   |      |   |                   |  |  |   |   |   |                |       |  |  |  |                 |                 |   |  |   |          |          |   |  |   |   |          |                         |  |   |
|                 |                             | A   | B    | C |                   |  |  |   |   |   |                |       |  |  |  |                 |                 |   |  |   |          |          |   |  |   |   |          |                         |  |   |
| X(mm)           | Y(mm)                       |   |      |   |                   |  |  |   |   |   |                |       |  |  |  |                 |                 |   |  |   |          |          |   |  |   |   |          |                         |  |   |
| L ≤ 3.0         | W ≤ 0.15                    | 4   |      | * |                   |  |  |   |   |   |                |       |  |  |  |                 |                 |   |  |   |          |          |   |  |   |   |          |                         |  |   |
| L > 3.0         | W ≤ 0.15                    | 0   |      | * |                   |  |  |   |   |   |                |       |  |  |  |                 |                 |   |  |   |          |          |   |  |   |   |          |                         |  |   |
| -               | W > 0.15                    | According to BLACK SPOT   |      | * |                   |  |  |   |   |   |                |       |  |  |  |                 |                 |   |  |   |          |          |   |  |   |   |          |                         |  |   |



| No.        | Parameter                      | Criteria   |                        |                   |   |  |   |   |   |            |                  |  |   |          |         |  |   |       |    |  |  |
|------------|--------------------------------|--|------------------------|-------------------|---|--|---|---|---|------------|------------------|--|---|----------|---------|--|---|-------|----|--|--|
| 5          | (a) Bright Dot<br>(b) Dark Dot | <table border="1"> <thead> <tr> <th rowspan="2">Zone<br/>Dimension (mm)</th> <th colspan="3">Acceptable Number</th> </tr> <tr> <th>A</th> <th>B</th> <th>C</th> </tr> </thead> <tbody> <tr> <td>Bright Dot</td> <td colspan="2">7 (<math>G \leq 3</math>)</td> <td>*</td> </tr> <tr> <td>Dark Dot</td> <td colspan="2">7</td> <td>*</td> </tr> <tr> <td>TOTAL</td> <td colspan="3">10</td> </tr> </tbody> </table> | Zone<br>Dimension (mm) | Acceptable Number |   |  | A | B | C | Bright Dot | 7 ( $G \leq 3$ ) |  | * | Dark Dot | 7       |  | * | TOTAL | 10 |  |  |
|            |                                | Zone<br>Dimension (mm)   |                        | Acceptable Number |   |  |   |   |   |            |                  |  |   |          |         |  |   |       |    |  |  |
|            |                                |  | A                      | B                 | C |  |   |   |   |            |                  |  |   |          |         |  |   |       |    |  |  |
|            |                                | Bright Dot   | 7 ( $G \leq 3$ )       |                   | * |  |   |   |   |            |                  |  |   |          |         |  |   |       |    |  |  |
| Dark Dot   | 7                              |  | *                      |                   |   |  |   |   |   |            |                  |  |   |          |         |  |   |       |    |  |  |
| TOTAL      | 10                             |  |                        |                   |   |  |   |   |   |            |                  |  |   |          |         |  |   |       |    |  |  |
| 6          | TWO Adjacent Dot               | <table border="1"> <thead> <tr> <th rowspan="2">Zone<br/>Dimension (mm)</th> <th colspan="3">Acceptable Number</th> </tr> <tr> <th>A</th> <th>B</th> <th>C</th> </tr> </thead> <tbody> <tr> <td>Bright Dot</td> <td colspan="2">3 PAIRS</td> <td>*</td> </tr> <tr> <td>Dark Dot</td> <td colspan="2">3 PAIRS</td> <td>*</td> </tr> </tbody> </table>   | Zone<br>Dimension (mm) | Acceptable Number |   |  | A | B | C | Bright Dot | 3 PAIRS          |  | * | Dark Dot | 3 PAIRS |  | * |       |    |  |  |
|            |                                | Zone<br>Dimension (mm)   |                        | Acceptable Number |   |  |   |   |   |            |                  |  |   |          |         |  |   |       |    |  |  |
|            |                                |  | A                      | B                 | C |  |   |   |   |            |                  |  |   |          |         |  |   |       |    |  |  |
| Bright Dot | 3 PAIRS                        |  | *                      |                   |   |  |   |   |   |            |                  |  |   |          |         |  |   |       |    |  |  |
| Dark Dot   | 3 PAIRS                        |  | *                      |                   |   |  |   |   |   |            |                  |  |   |          |         |  |   |       |    |  |  |
| 7          | Three or More Adjacent Dot     | NOT ALLOWED  |                        |                   |   |  |   |   |   |            |                  |  |   |          |         |  |   |       |    |  |  |
| 8          |                                | <table border="1"> <thead> <tr> <th rowspan="2">Zone<br/>Dimension (mm)</th> <th colspan="3">Acceptable Number</th> </tr> <tr> <th>A</th> <th>B</th> <th>C</th> </tr> </thead> <tbody> <tr> <td>Bright Dot</td> <td colspan="2">5 mm</td> <td>*</td> </tr> <tr> <td>Dark Dot</td> <td colspan="2">5 mm</td> <td>*</td> </tr> </tbody> </table>   | Zone<br>Dimension (mm) | Acceptable Number |   |  | A | B | C | Bright Dot | 5 mm             |  | * | Dark Dot | 5 mm    |  | * |       |    |  |  |
|            |                                | Zone<br>Dimension (mm)   |                        | Acceptable Number |   |  |   |   |   |            |                  |  |   |          |         |  |   |       |    |  |  |
|            |                                |  | A                      | B                 | C |  |   |   |   |            |                  |  |   |          |         |  |   |       |    |  |  |
| Bright Dot | 5 mm                           |  | *                      |                   |   |  |   |   |   |            |                  |  |   |          |         |  |   |       |    |  |  |
| Dark Dot   | 5 mm                           |  | *                      |                   |   |  |   |   |   |            |                  |  |   |          |         |  |   |       |    |  |  |
| 9          | Line Defect                    | NOT ALLOWED  |                        |                   |   |  |   |   |   |            |                  |  |   |          |         |  |   |       |    |  |  |

Note 1: Bright Dot is defined as follows:

Visible through 5% transmission ND filter under the condition that black image (color 0) is on the display.

Note 2: Dark Dot is defined as follows:

Recognizable darker than around under the condition that each R(63), G(63), B(63) image is on the display.

Note 3: Definition of adjacent

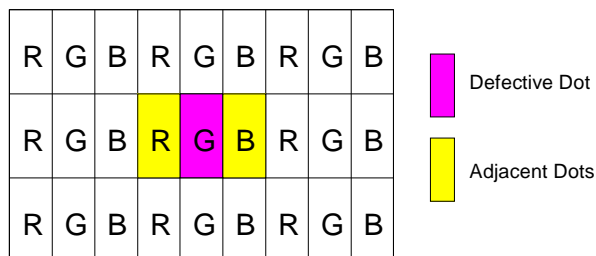

The defects that are not defined above and considered to be problem shall be reviewed and discussed by both parties.

10.4 Standards on Touch panel

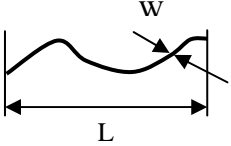
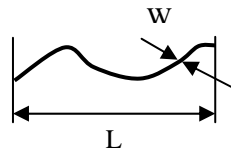
| No. | Item                                    | Criteria  |   | Note  |
|-----|---|---|---|---|
| 1   | Dot type foreign material, Dent         | Dimension (mm)  |   | D(mm): average diameter=(Long dia.+ short dia.)/2                                     |
|     |   | Judgment  |   |   |
|     |   | $D \leq 0.15$   | Disregard   |   |
|     |   | $0.15 < D < 0.25$   | Distance from any other foreign object<br>>20mm : Ignore<br><20mm : less than 2pcs    |   |
|     |   | $D > 0.25$  | Nothing   |   |
| 2   | Linear foreign material, Linear scratch | Dimension (mm)  |   |    |
|     |   | Judgment  |   |   |
|     |   | $W < 0.025$   | Disregard   |   |
|     |   | $0.025 < W < 0.035$ $L \leq 2.5$  | Distance from any other foreign object<br>>20mm : Ignore<br><20mm : less than 2pcs    |   |
|     |   | $0.035 < W < 0.05$ $L \leq 1.5$   | less than 2pcs  |   |
|     |   | $W > 0.05$ $L < 5$ mm   | Nothing   |   |
| 3   | Glass chipping                          | <b>Corner</b><br>1) $X \leq 3.0$ mm, $Y \leq 3.0$ mm, $Z \leq$ Glass thickness : Ignore<br>2) the chipping on the terminal : Not allowable<br>3) the chipping on the Circuit : Not allowable<br><b>Without corner</b><br>1) $X < 4.0$ mm, $Y < 2.0$ mm, $Z <$ Glass thickness : Ignore<br>2) the chipping on the terminal : Not allowable<br>3) the chipping on the Circuit : Not allowable |   |   |
| 4   | Scratch                                 | Dimension (mm)  |   |  |
|     |   | Judgment  |   |   |
|     |   | $W < 0.03$ , $L \leq 10$  | Ignore  |   |
|     |   | $0.03 < W < 0.05$ , $L \leq 10$   | Distance from any other scratch object<br>>20mm : Ignore<br><20mm : 1pcs is allowable |   |
|     |   | $0.03 < W < 0.05$ , $L > 10$  | Nothing   |   |
|     |   | $W > 0.05$  | Nothing   |   |

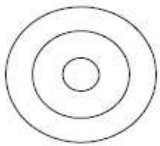
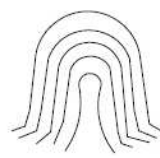
| 5 | Fish eye on film, Dent on film and Air bubble | Dimension (mm)   | Judgment 判定    | D(mm): average diameter=(Long dia.+ short dia.)/2   |
|---|---|--|----------------|---|
|   |   | $D \leq 0.2$   | Disregard      |   |
|   |   | $0.2 < D \leq 0.4$   | Less than 5pcs |   |
|   |   | $0.4 < D \leq 0.5$   | Less than 2pcs |   |
|   |   | $D > 0.5$  | Nothing        |   |
| 6 | Newton's ring                                 | <p>Visual inspection shall be done at a distance of 0.3 m between eyes and a product with an angles of <math>60^\circ \pm 10^\circ</math> to the surface of the product under a ceiling fluorescent light (40W, natural color).</p> <p><b>1. Regular</b><br/> A) When Newton ring dimension is more than 1/3 of sample dimension; it is regarded as a defect.<br/> B) When Newton ring dimension that is less than 1/3 of sample dimension and is not affect font effect and line distortion under a ceiling fluorescent light, it is acceptable.</p> <p><b>2. Irregular</b><br/> A) Newton ring dimension is more than 1/2 without lighting; it is regarded as a defect.<br/> B) As long as Newton ring affects font effect and line distortion under a ceiling fluorescent light, it is regarded as a defect.<br/> C) When Newton ring dimension is less than 1/2 of sample dimension and is not affect font effect and line distortion under a ceiling fluorescent light, it is acceptable.</p> |                |  <p>Regular</p>  <p>Irregular</p> |
| 7 | Miss matching of film and plastic board.      | All round of film is inside of plastic board.  |                |   |

## 11. Code System of Production Lot

The production lot of module is specified as follows.

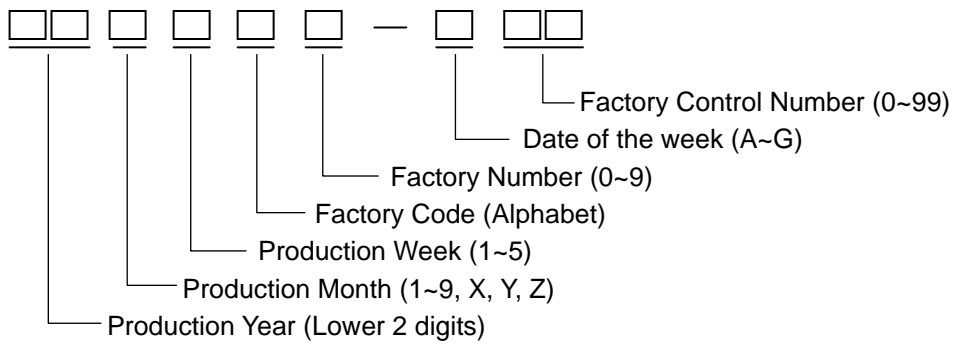

## 12. Type Number

The type number of module is specified as follows.

T-51750GD065J-LW-BHN

## 13. Applying Precautions

Please contact us when questions and/or new problems not specified in this Specifications arise.

## 14. Precautions Relating Product Handling

The Following precautions will guide you in handling our product correctly.

1) Liquid crystal display devices

1. The liquid crystal display device panel used in the liquid crystal display module is made of plate glass. Avoid any strong mechanical shock. Should the glass break handle it with care.
2. The polarizer adhering to the surface of the LCD is made of a soft material. Guard against scratching it.



2) **Care of the liquid crystal display module against static electricity discharge.**

1. **When working with the module, be sure to ground your body and any electrical equipment you may be using. We strongly recommend the use of anti static mats ( made of rubber ), to protect work tables against the hazards of electrical shock.**
2. **Avoid the use of work clothing made of synthetic fibers. We recommend cotton clothing or other conductivity-treated fibers.**
3. **Slowly and carefully remove the protective film from the LCD module, since this operation can generate static electricity.**

3) When the LCD module alone must be stored for long periods of time:

1. Protect the modules from high temperature and humidity.
2. Keep the modules out of direct sunlight or direct exposure to ultraviolet rays.
3. Protect the modules from excessive external forces.

4) Use the module with a power supply that is equipped with an over current protector circuit, since the module is not provided with this protective feature.

5) Do not ingest the LCD fluid itself should it leak out of a damaged LCD module. Should hands or clothing come in contact with LCD fluid, wash immediately with soap.

6) Conductivity is not guaranteed for models that use metal holders where solder connections between the metal holder and the PCB are not used. Please contact us to discuss appropriate ways to assure conductivity.

7) For models which use CFL:

1. High voltage of 1000V or greater is applied to the CFL cable connector area. Care should be taken not to touch connection areas to avoid burns.
2. Protect CFL cables from rubbing against the unit and thus causing the wire jacket to become worn.
3. The use of CFLs for extended periods of time at low temperatures will significantly shorten their service life.

8) For models which use touch panels:

1. Do not stack up modules since they can be damaged by components on neighboring modules.
2. Do not place heavy objects on top of the product. This could cause glass breakage.

9) For models which use COG, TAB, or COF:

1. The mechanical strength of the product is low since the IC chip faces out unprotected from the rear. Be sure to protect the rear of the IC chip from external forces.
2. Given the fact that the rear of the IC chip is left exposed, in order to protect the unit from electrical damage, avoid installation configurations in which the rear of the IC chip runs the risk of making any electrical contact.

- 10) Models which use flexible cable, heat seal, or TAB:
  1. In order to maintain reliability, do not touch or hold by the connector area.
  2. Avoid any bending, pulling, or other excessive force, which can result in broken connections.
  
- 11) In case of buffer material such as cushion / gasket is assembled into LCD module, it may have an adverse effect on connecting parts ( LCD panel-TCP / HEAT SEAL / FPC / etc., PCB-TCP / HEAT SEAL / FPC etc., TCP-HEAT SEAL, TCP-FPC, HEAT SEAL-FPC, etc.,) depending on its materials.  
Please check and evaluate these materials carefully before use.
  
- 12) In case of acrylic plate is attached to front side of LCD panel, cloudiness ( very small cracks ) can occur on acrylic plate, being influenced by some components generated from polarizer film.. Please check and evaluate those acrylic materials carefully before use.
  
- 13) Flickering due to optical interference may occur by combination of a) LCD driving frame frequency decided by either internal oscillator in driver IC or external clock input by the customer and b) lighting frequency of either backlight or other light sources.  
Please evaluate enough at the environment of actual use, and decide the driving condition that does not cause flickering.

## 15. Warranty

This product has been manufactured to your company's specifications as a part for use in your company's general electronic products. It is guaranteed to perform according to delivery specifications. For any other use apart from general electronic equipment, we cannot take responsibility if the product is used in medical devices, nuclear power control equipment, aerospace equipment, fire and security systems, or any other applications in which there is a direct risk to human life and where extremely high levels of reliability are required. If the product is to be used in any of the above applications, we will need to enter into a separate product liability agreement.

1. We cannot accept responsibility for any defect, which may arise from additional manufacturing of the product (including disassembly and reassembly), after product delivery.
  
2. We cannot accept responsibility for any defect, which may arise after the application of strong external force to the product.
  
3. We cannot accept responsibility for any defect, which may arise due to the application of static electricity after the product has passed your company's acceptance inspection procedures.
  
4. When the product is in CFL models, CFL service life and brightness will vary according to the performance of the inverter used, leaks, etc. We cannot accept responsibility for product performance, reliability, or defect, which may arise.
  
5. We cannot accept responsibility for intellectual property of a third party, which may arise through the application of our product to your assembly with exception to those issues relating directly to the structure or method of manufacturing of our product.
  
6. We will not be held responsible for any quality guarantee issue for defect products judged as our-origin in 2 (two) years from our production or 1(one) year from KYOCERA Display Group delivery which ever is shorter.

## X-ON Electronics

Largest Supplier of Electrical and Electronic Components

*Click to view similar products for [TFT Displays & Accessories category](#):*

*Click to view products by [Kyocera Display manufacturer](#):*

Other Similar products are found below :

[HDA430T-3G1H](#) [NB7W-KBA04](#) [NB5Q-ATT01](#) [NB5Q-KBA04](#) [NB-CN001](#) [OAI-80038AA-2008-A](#) [315-U004B15300](#) [EIC-LCD-1080P](#) [T-55619GD065J-LW-ABN](#) [TCG104SVLPEANN-AN30](#) [NL6448BC20-30D](#) [NL10276BC16-06](#) [NL192108AC10-01D](#) [NL8060BC26-35BA](#) [NL8060BC31-50F](#) [TM070DDHG03-40](#) [PTPW16-070WV1S02](#) [PTPW16-084SV1S02](#) [MTD0300ECP06DF-1](#) [DEM 320240T VMX-PW-N \(A-TOUCH\)](#) [DEM 480128B TMH-PW-N \(A-TOUCH\)](#) [DEM 480272P VMX-PW-N \(C-TOUCH\)](#) [DEM 480272Q VMX-PW-N \(A-TOUCH\)](#) [DEM 480272Q VMX-PW-N \(C-TOUCH\)](#) [DEM 640480E TMH-PW-N \(A-TOUCH\)](#) [DEM 800480K1 TMH-PW-N \(A-TOUCH\)](#) [DEM 800480K1 TMH-PW-N \(C-TOUCH\)](#) [DEM 800480K2 TMH-PW-N \(A-TOUCH\)](#) [DEM 800480K3 TMH-PW-N \(C-TOUCH\)](#) [DEM 800480K4 TMH-PW-N \(A-TOUCH\)](#) [DEM 800480K4 TMH-PW-N \(C-TOUCH\)](#) [4DLCD-35480320-CTP-IPS](#) [4DLCD-35480320-IPS](#) [4DLCD-35480320-RTP-IPS](#) [4DLCD-50800480-CTP-IPS](#) [RFA6400E-AWH-DNG](#) [RFA6400E-AWH-MNN](#) [RFE430V-AZW-DNS](#) [RFF70VA2-1IW-DHS](#) [RFH700A8-AYH-MNN](#) [RFK101VF-1YH-LHG](#) [RFS390C-AIW-DNN](#) [RFS390C-AIW-DNS](#) [RFS52VA-1ZH-DHN](#) [SM-RVT101HVHFWN00](#) [SM-RVT101HVHNWCA0](#) [SM-RVT101HVHNWN00](#) [SM-RVT101HVLFWCA0](#) [SM-RVT101HVLNWCA0](#) [SM-RVT35HHTFWCA0](#)