

SPEC for Mass Production

Spec No.	TQ3C-8EAF0-E1YAF115-00
Date	September 20, 2023

TYPE : TCG084SVLRGVNN-AN41

< 8.4 inch SVGA transmissive color TFT

with LED backlight and constant current circuit for LED backlight>

CONTENTS

1. Application
2. Construction and outline
3. Mechanical specifications
4. Absolute maximum ratings
5. Electrical characteristics
6. Optical characteristics
7. Interface signals
8. Input timing characteristics
9. Lot number identification
10. Warranty
11. Precautions for use
12. Reliability test data
13. Outline drawing



KYOCERA CORPORATION

This specification is subject to change without notice.
Consult Kyocera before ordering.

Original Issue Date	Designed by: Engineering dept.			Confirmed by: QA dept.
	Prepared	Checked	Approved	Approved
September 20, 2023	<i>Y. Takakura</i>	<i>T. Fukui</i>	<i>A. Iwasaki</i>	<i>T. Sawada</i>

Spec No. TQ3C-8EAF0-E1YAF115-00	Part No. TCG084SVLRGVNN-AN41	Page -
------------------------------------	---------------------------------	-----------

Warning

1. This Kyocera LCD module has been specifically designed for use only in electronic devices and industrial machines in the area of audio control, office automation, industrial control, home appliances, etc. The module should not be used in applications where the highest level of safety and reliability are required and module failure or malfunction of such module results in physical harm or loss of life, as well as enormous damage or loss. Such fields of applications include, without limitation, medical, aerospace, communications infrastructure, atomic energy control. Kyocera expressly disclaims any and all liability resulting in any way to the use of the module in such applications.

2. Customer agrees to indemnify, defend and hold Kyocera harmless from and against any and all actions, claims, damages, liabilities, awards, costs, and expenses, including legal expenses, resulting from or arising out of Customer's use, or sale for use, or Kyocera modules in applications.

Caution

1. Kyocera shall have the right, which Customer hereby acknowledges, to immediately scrap or destroy tooling for Kyocera modules for which no Purchase Orders have been received from the Customer in a two-year period.

2. Please note that we may not be able to respond to new environmental regulations after receiving the final mass production order for this product.

Spec No. TQ3C-8EAF0-E1YAF115-00	Part No. TCG084SVLRGVNN-AN41	Page -
------------------------------------	---------------------------------	-----------

Revision record

Date		Designed by : Engineering dept.			Confirmed by : QA dept.
		Prepared	Checked	Approved	Approved
Rev.No.	Date	Page	Descriptions		

1. Application

This document defines the specification of TCG084SVLRGVNN-AN41. (RoHS Compliant)

2. Construction and outline

LCD	: Transmissive color dot matrix type TFT
Backlight system	: LED
Polarizer	: Anti-Glare treatment
Interface	: LVDS
Additional circuit	: Timing controller, Power supply (3.3V input) With Constant current circuit for LED Backlight (12V input)

3. Mechanical specifications

Item	Specification	Unit
Outline dimensions 1)	199.5(W)×149(H)×11.5(D)	mm
Active area	170.4(W)×127.8(H) (21.3cm/8.4 inch (Diagonal))	mm
Dot format	800×(R,G,B)(W)×600(H)	dot
Dot pitch	0.071(W)×0.213(H)	mm
Base color 2)	Normally Black	-
Mass	360	g

1) Projection not included. Please refer to outline for details.

2) Due to the characteristics of the LCD material, the color varies with environmental temperature.

4. Absolute maximum ratings

4-1. Electrical absolute maximum ratings

Item		Symbol	Min.	Max.	Unit
Supply voltage(+3.3V)		V _{DD}	-0.3	4.0	V
Supply voltage(+12V)		V _{IN}	-0.3	14.0	V
Input signal voltage 2)	RxINi+, RxINi- 1)	V _{I1}	-0.3	2.8	V
	CK IN+, CK IN-	V _{I2}	-0.3	2.8	V
	SELLVDS, SC	V _{I3}	-0.3	V _{DD} +0.5	V
	BLBRT, BLEN	V _{I4}	-0.3	V _{IN}	V

- 1) i=0,1,2,3
- 2) V_{DD} must be supplied correctly within the range described in 5-1.

4-2. Environmental absolute maximum ratings

Item		Symbol	Min.	Max.	Unit
Operating temperature (Ambient) 1)		T _{OP} (Ambient)	-30	80	°C
Operating temperature (Panel) 2)		T _{OP} (Panel)	-30	80	°C
Storage temperature 3)		T _{STO}	-30	80	°C
Operating humidity 4)		H _{OP}	10	5)	%RH
Storage humidity 4)		H _{STO}	10	5)	%RH
Vibration		-	6)	6)	-
Shock		-	7)	7)	-

- 1) Operating temperature means a temperature which operation shall be guaranteed. Since display performance is evaluated at 25°C, another temperature range should be confirmed.
- 2) Panel surface temperature (all the surface)
- 3) Temp. = -30°C < 48h , Temp. = 80°C < 168h
Store LCD at normal temperature/humidity. Keep them free from vibration and shock.
An LCD that is kept at a low or a high temperature for a long time can be defective due to other conditions, even if the low or high temperature satisfies the standard.
(Please refer to “Precautions for Use” for details.)
- 4) Non-condensing
- 5) Temp. ≤ 40°C, 85%RH Max.
Temp. > 40°C, Absolute humidity shall be less than 85%RH at 40°C.
- 6)

Frequency	10~55 Hz	Acceleration value (0.3~9 m/s ²)
Vibration width	0.15mm	
Interval	10-55-10 Hz	1minute

2 hours in each direction X, Y, Z (6 hours total)

EIAJ ED-2531

- 7) Acceleration: 490 m/s², Pulse width: 11 ms
3 times in each direction: ±X, ±Y, ±Z
EIAJ ED-2531

5. Electrical characteristics

5-1. LCD

Temp. = -30~80°C

Item	Symbol	Condition	Min.	Typ.	Max.	Unit
Supply voltage 1)	V_{DD}	-	3.0	3.3	3.6	V
Current consumption	I_{DD}	2)	-	230	300	mA
Permissible input ripple voltage	V_{RP}	$V_{DD}=3.3V$	-	-	100	mVp-p
Input signal voltage 3)	V_{IL}	"Low" level	0	-	0.8	V
	V_{IH}	"High" level	2.0	-	V_{DD}	V
Input leak current	I_{IL}	$V_{I3}=0V$	-10	-	10	μA
	I_{IH}	$V_{I3}=3.3V$	-	-	400	μA
LVDS input voltage 4)	V_L	-	0	-	1.9	V
Differential input voltage 4)	V_{ID}	-	100	-	600	mV
Differential input threshold voltage 4) 5)	V_{TL}	"Low" level	$V_{CM}-100$	-	-	mV
	V_{TH}	"High" level	-	-	$V_{CM}+100$	mV
Terminator	R_1	-	-	100	-	Ω
V_{DD} -turn-on conditions 1)	t_1	-	0.1	-	10	ms
	t_2	-	0	-	-	ms
	t_3	-	0	-	-	ms
	t_4	-	1.0	-	-	s
	t_5	-	200	-	-	ms
	t_6	-	200	-	-	ms

1) V_{DD} -turn-on conditions

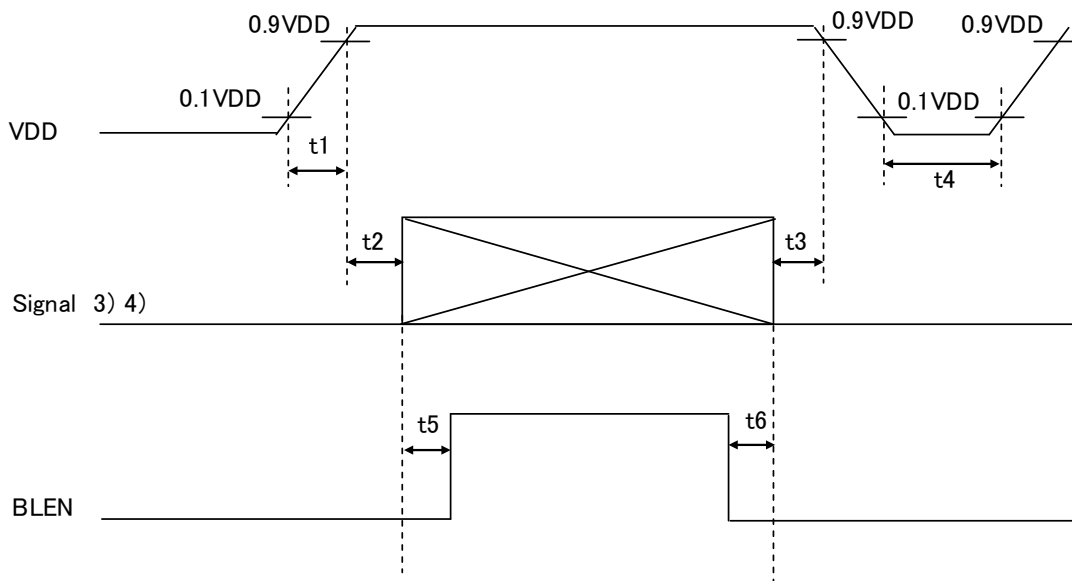

2) Display pattern:

$V_{DD} = 3.3V$, Temp. = 25°C

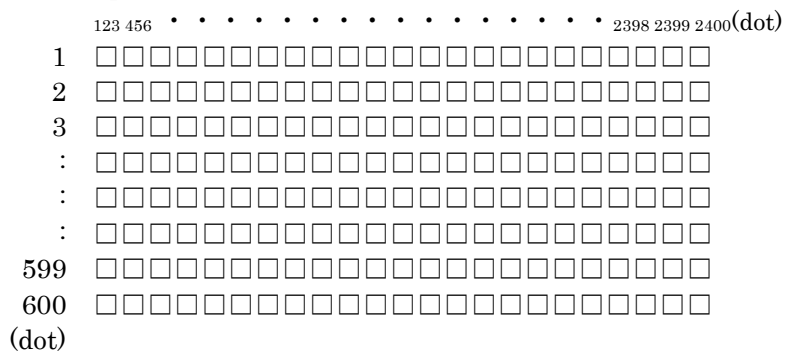

3) Input signal : SELLVDS, SC

4) Input signal : RxIN3+, RxIN3-, RxIN2+, RxIN2-, RxIN1+, RxIN1-, RxIN0+, RxIN0-, CK IN+, CK IN-

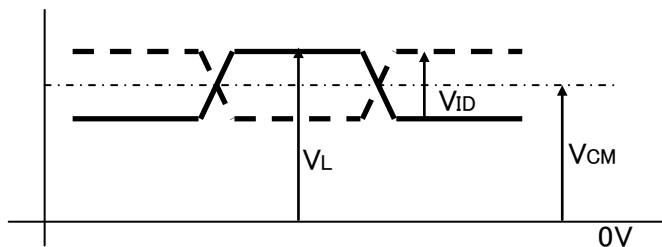

5) V_{CM} : LVDS Common mode voltage ($V_{CM}=1.25V$)

5-2. Constant current circuit for LED Backlight

Temp. = -30~80°C

Item	Symbol	Condition	Min.	Typ.	Max.	Unit
Supply voltage 1)	V_{IN}	-	10.8	12.0	13.2	V
Current consumption	I_{IN}	2)	-	315	360	mA
Permissive input ripple voltage	V_{RP_BL}	$V_{IN}=12.0V$	-	-	100	mVp-p
BLBRT Input signal voltage	V_{IL_BLBRT}	"Low" level	0	-	0.8	V
	V_{IH_BLBRT}	"High" level	2.3	-	V_{IN}	V
BLBRT Input pull-down resistance	R_{IN_BLBRT}	-	100	300	500	k Ω
BLEN Input signal voltage	V_{IL_BLEN}	"Low" level	0	-	0.8	V
	V_{IH_BLEN}	"High" level	2.3	-	V_{IN}	V
BLEN Input pull-down resistance	R_{IN_BLEN}	-	100	300	500	k Ω
PWM Frequency 3)	f_{PWM}	-	200	-	10k	Hz
PWM Duty ratio	D_{PWM}	$f_{PWM}=200Hz$	1	-	100	%
		$f_{PWM}=2kHz$	10	-	100	%
		$f_{PWM}=10kHz$	50	-	100	%
Operating life time 4), 5)	T	Temp.=25°C	-	50,000	-	h

1) V_{IN} -turn-on conditions

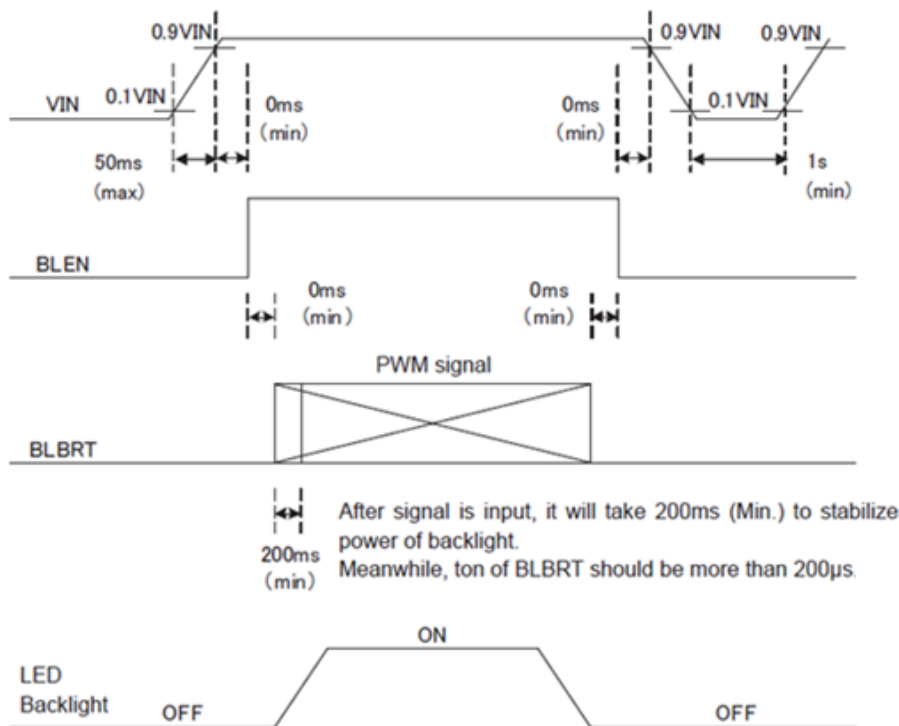

2) $V_{IN} = 12V$, Temp. = 25°C, $D_{PWM} = 100\%$

3) PWM timing diagram

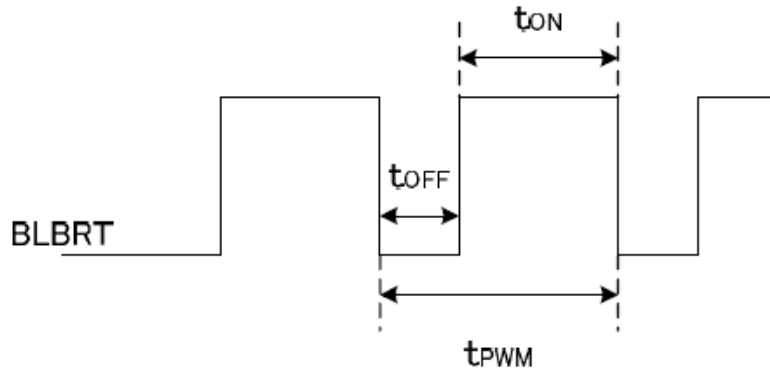

Please do not set t_{OFF} with $0 \mu s < t_{OFF} < 1 \mu s$.

In case of lower frequency, the deterioration of the display quality, flicker etc., may occur.

- 4) When brightness decrease 50% of minimum brightness.
The average life of a LED will decrease when the LCD is operating at higher temperatures.
- 5) Life time is estimated data. (Condition : $D_{PWM} = 100\%$, $T_a = 25^\circ C$ in chamber).

6. Optical characteristics

Measuring spot = ϕ 6.0mm, Temp. = 25°C

Item	Symbol	Condition	Min.	Typ.	Max.	Unit	
Response time	Rise	τ_r	$\theta = \phi = 0^\circ$	-	18	-	ms
	Down	τ_d	$\theta = \phi = 0^\circ$	-	12	-	ms
Viewing angle range	θ UPPER	$CR \geq 10$	-	85	-	deg.	
	θ LOWER		-	85	-		
	ϕ LEFT		-	85	-	deg.	
	ϕ RIGHT		-	85	-		
Contrast ratio	CR	$\theta = \phi = 0^\circ$	500	750	-	-	
Brightness	L	DPWM = 100%	1000	1200	-	cd/m ²	
Chromaticity coordinates	Red	x	$\theta = \phi = 0^\circ$	0.525	0.575	0.625	-
		y		0.240	0.290	0.340	
	Green	x	$\theta = \phi = 0^\circ$	0.285	0.335	0.385	
		y		0.520	0.570	0.620	
	Blue	x	$\theta = \phi = 0^\circ$	0.105	0.155	0.205	
		y		0.075	0.125	0.175	
	White	x	$\theta = \phi = 0^\circ$	0.240	0.290	0.340	
		y		0.275	0.325	0.375	

6-1. Definition of contrast ratio

$$CR(\text{Contrast ratio}) = \frac{\text{Brightness with all pixels "White"}}{\text{Brightness with all pixels "Black"}}$$

6-2. Definition of response time

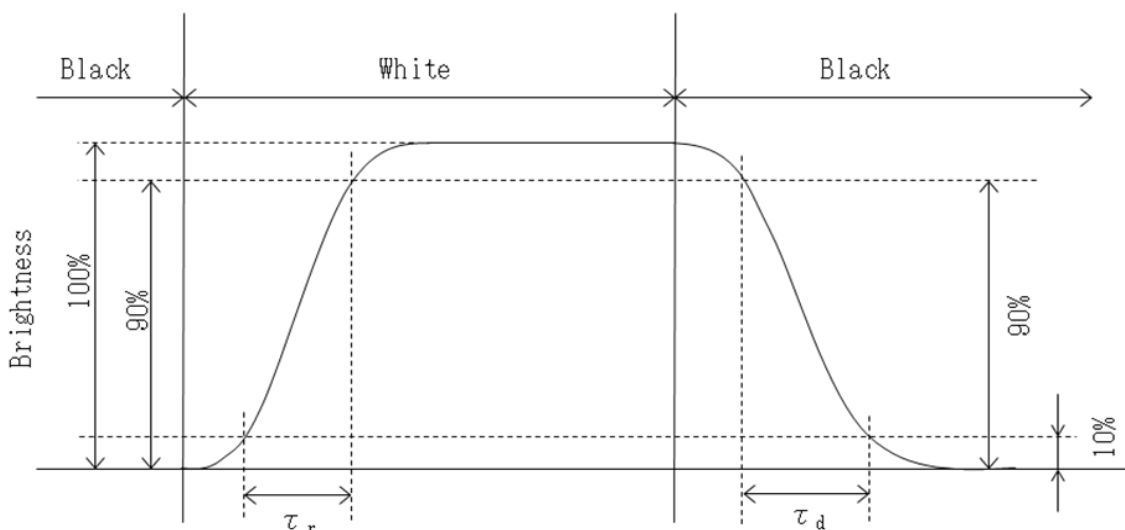

6-3. Definition of viewing angle

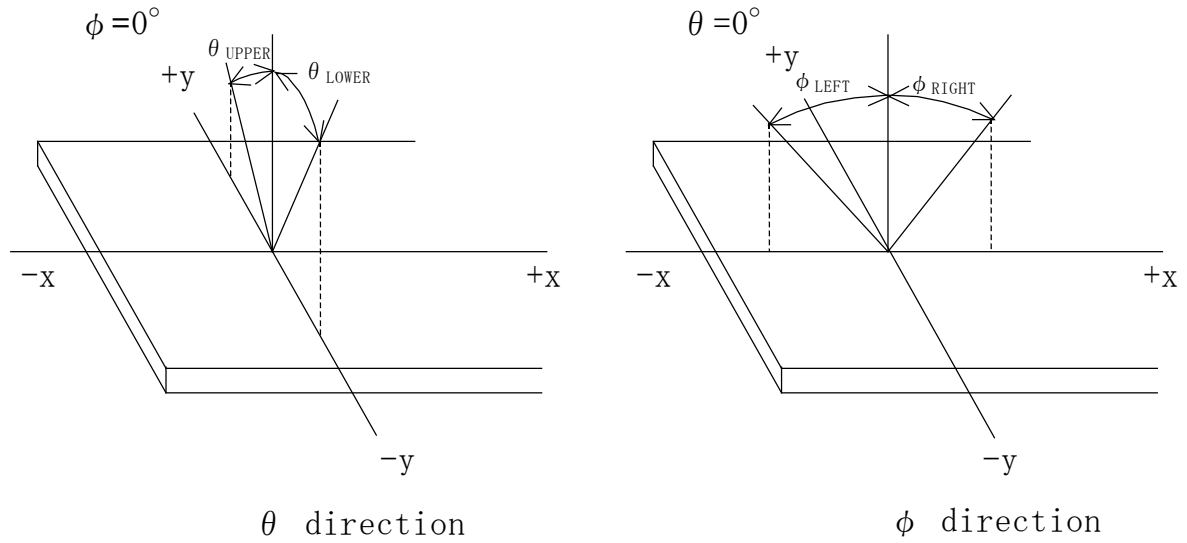

6-4. Brightness measuring point

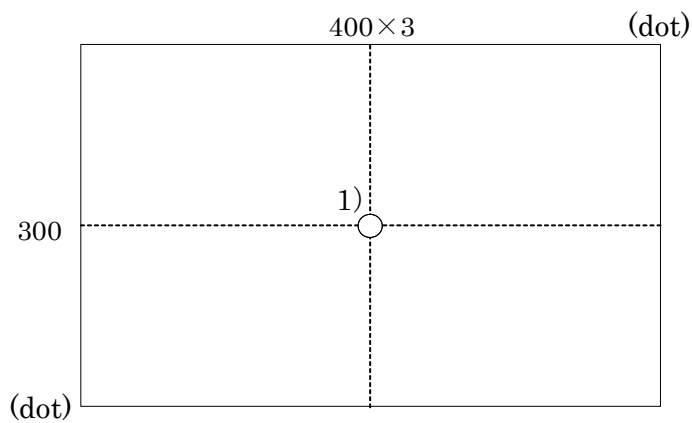

- 1) Rating is defined as the white brightness at center of display screen.
- 2) 5 minutes after LED is turned on. (Ambient Temp.=25°C)

7. Interface signals

7-1. LCD

No.	Symbol	Description	Note
1	GND	GND	
2	SELLVDS	Mode select signal (LVDS Data mapping)	
3	GND	GND	
4	GND	GND	
5	RxIN3+	LVDS receiver signal CH3(+)	LVDS
6	RxIN3-	LVDS receiver signal CH3(-)	LVDS
7	GND	GND	
8	CK IN+	LVDS receiver signal CK(+)	LVDS
9	CK IN-	LVDS receiver signal CK(-)	LVDS
10	GND	GND	
11	RxIN2+	LVDS receiver signal CH2(+)	LVDS
12	RxIN2-	LVDS receiver signal CH2(-)	LVDS
13	GND	GND	
14	RxIN1+	LVDS receiver signal CH1(+)	LVDS
15	RxIN1-	LVDS receiver signal CH1(-)	LVDS
16	GND	GND	
17	RxIN0+	LVDS receiver signal CH0(+)	LVDS
18	RxIN0-	LVDS receiver signal CH0(-)	LVDS
19	GND	GND	
20	GND	GND	
21	V _{DD}	+3.3V power supply	
22	V _{DD}	+3.3V power supply	
23	SC	Scan direction control (GND or Open: Normal, High: Reverse)	1)
24	BLBRT	PWM signal (Brightness adjustment)	
25	BLEN	ON/OFF terminal voltage	
26	GND	GND	
27	V _{IN}	+12V power supply	
28	V _{IN}	+12V power supply	
29	GND	GND	
30	GND	GND	

LCD connector : FI-X30SSLA-HF (JAE)
 Matching connector : FI-X30HL (JAE)
 : FI-X30C-NPB (JAE)
 : FI-X30MA1 (JAE)

LVDS receiver : Embedded in ASIC
 Matching LVDS transmitter : THC63LVDM83D(THine Electronics) or compatible

1) Scan direction

SC : GND or Open

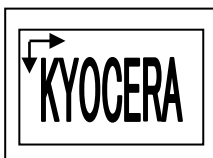

SC : High

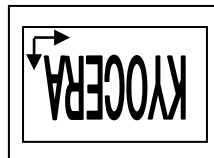

7-2. Data mapping (6bit RGB input)

1) Location of SELLVDS (THC63LVDM83D (THine Electronics) or compatible)

Transmitter		SELLVDS	
Pin No.	Data	L(GND) or OPEN	H(3.3V)
51	TA0	—	R0(LSB)
52	TA1	—	R1
54	TA2	—	R2
55	TA3	—	R3
56	TA4	—	R4
3	TA5	—	R5(MSB)
4	TA6	—	G0(LSB)
6	TB0	—	G1
7	TB1	—	G2
11	TB2	—	G3
12	TB3	—	G4
14	TB4	—	G5(MSB)
15	TB5	—	B0(LSB)
19	TB6	—	B1
20	TC0	—	B2
22	TC1	—	B3
23	TC2	—	B4
24	TC3	—	B5(MSB)
27	TC4	—	(HS)
28	TC5	—	(VS)
30	TC6	—	DE
50	TD0	—	GND
2	TD1	—	GND
8	TD2	—	GND
10	TD3	—	GND
16	TD4	—	GND
18	TD5	—	GND
25	TD6	—	GND

SELLVDS=H (3.3V)

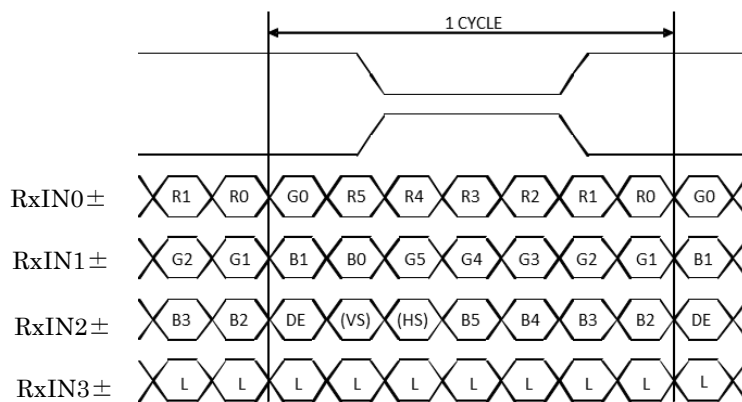

DE : DATA ENABLE

HS : H_{SYNC}

VS : V_{SYNC}

2) Block diagram

SELLVDS=H (3.3V)

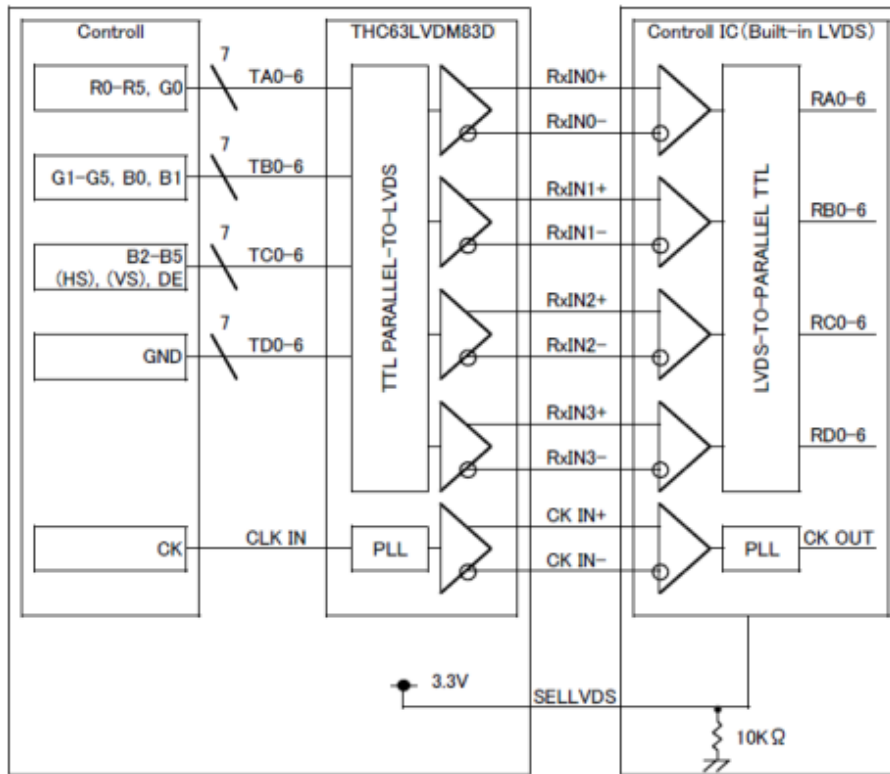

*SELLVDS signal line has 10 k Ω pull-down resistor.

When using “6-bit Transmitter”, please connect the unused channel of the control IC receiver as described in the diagram below.

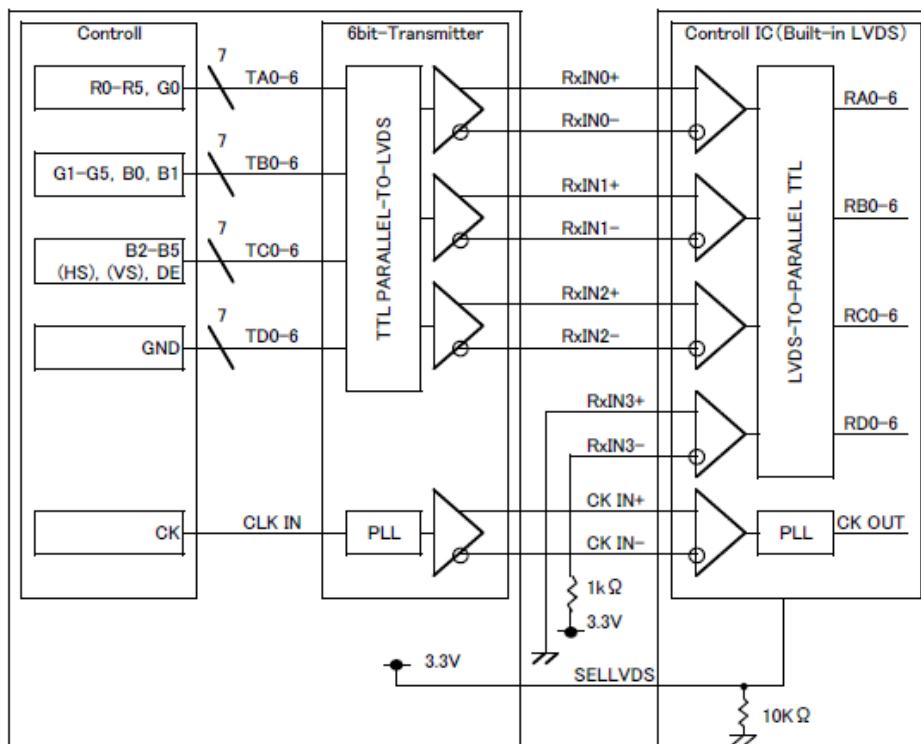

*SELLVDS signal line has 10 k Ω pull-down resistor.

7-3. Data mapping (8bit RGB input)

1) Location of SELLVDS (THC63LVDM83D (THine Electronics) or compatible)

Transmitter		SELLVDS	
Pin No.	Data	L(GND) or OPEN	H(3.3V)
51	TA0	R0(LSB)	R2
52	TA1	R1	R3
54	TA2	R2	R4
55	TA3	R3	R5
56	TA4	R4	R6
3	TA5	R5	R7(MSB)
4	TA6	G0(LSB)	G2
6	TB0	G1	G3
7	TB1	G2	G4
11	TB2	G3	G5
12	TB3	G4	G6
14	TB4	G5	G7(MSB)
15	TB5	B0(LSB)	B2
19	TB6	B1	B3
20	TC0	B2	B4
22	TC1	B3	B5
23	TC2	B4	B6
24	TC3	B5	B7(MSB)
27	TC4	(HS)	(HS)
28	TC5	(VS)	(VS)
30	TC6	DE	DE
50	TD0	R6	R0(LSB)
2	TD1	R7(MSB)	R1
8	TD2	G6	G0(LSB)
10	TD3	G7(MSB)	G1
16	TD4	B6	B0(LSB)
18	TD5	B7(MSB)	B1
25	TD6	(NA)	(NA)

SELLVDS=L (GND) or OPEN

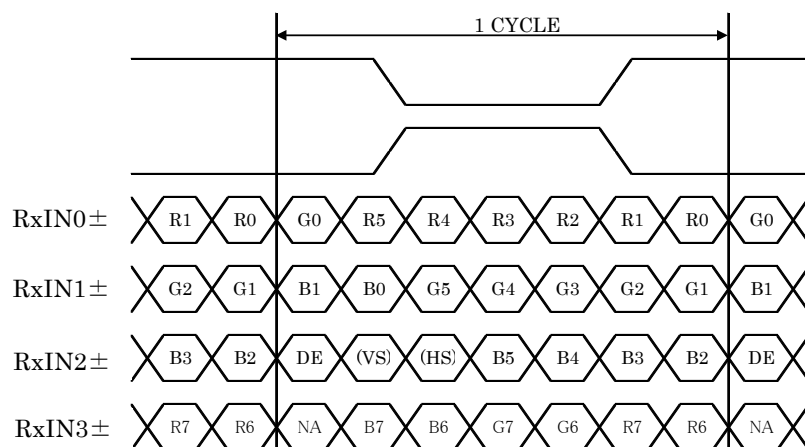

DE : DATA ENABLE

HS : H_{SYNC}

VS : V_{SYNC}

SELLVDS=H (3.3V)

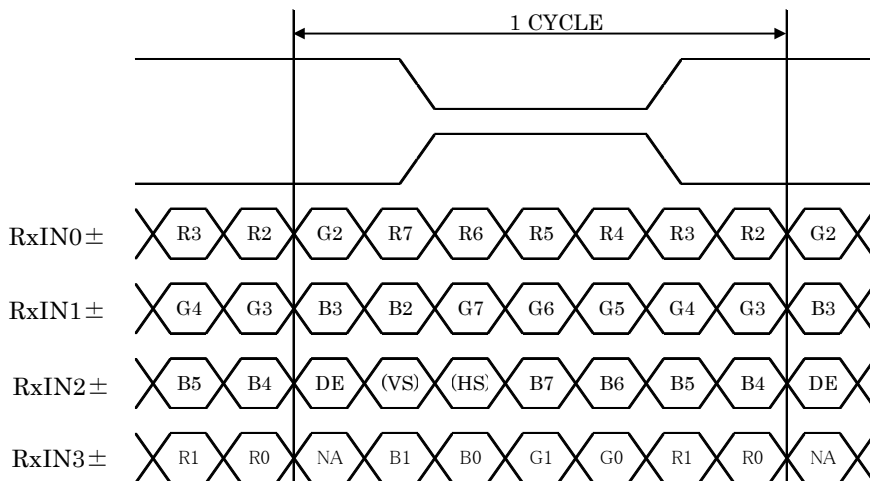

DE : DATA ENABLE
 HS : H_{SYNC}
 VS : V_{SYNC}

2) Block diagram

SELLVDS=L (GND) or OPEN

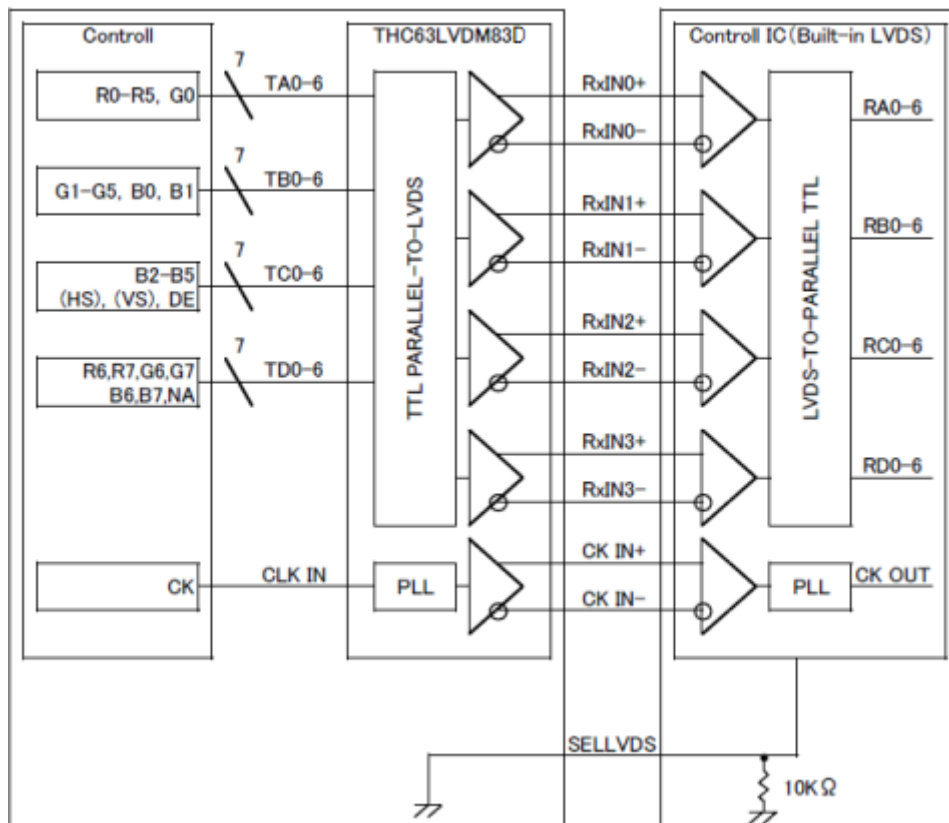

*SELLVDS signal line has 10 k Ω pulldown resistor.

SELLVDS=H (3.3V)

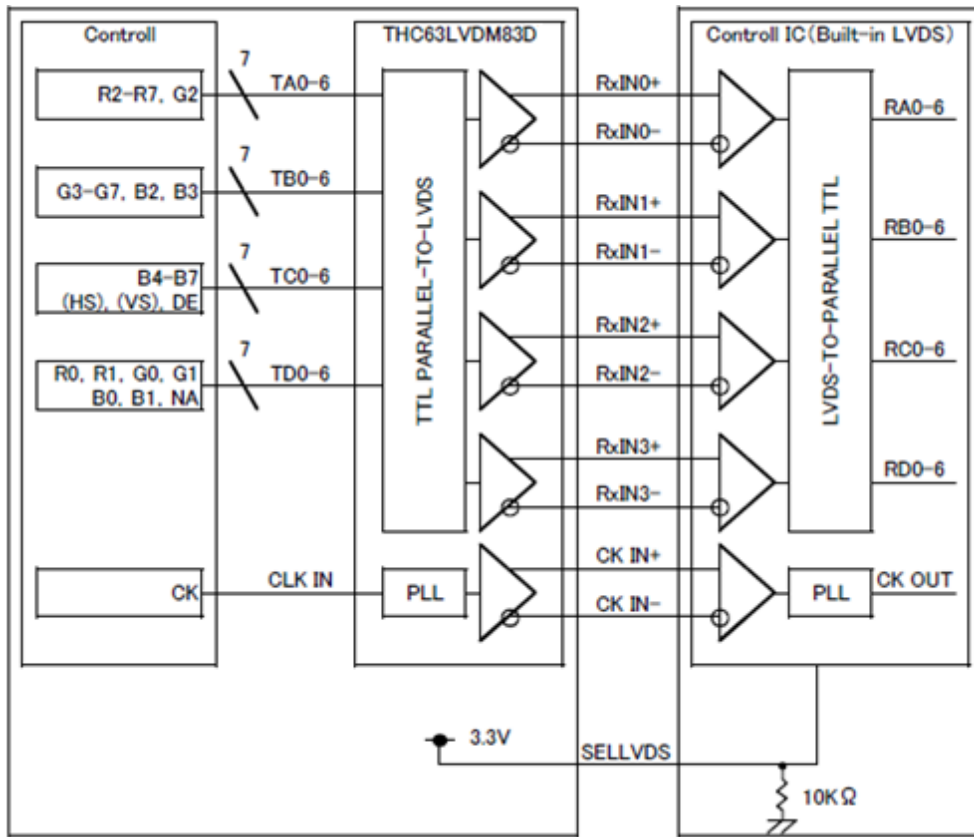

*SELLVDS signal line has 10 k Ω pulldown resistor.

8. Input timing characteristics

8-1. Timing characteristics 1)

Item		Symbol	Min.	Typ.	Max.	Unit	Note
Clock (CK)	Frequency	1/Tc	30	40	48	MHz	
Enable signal (DE)	Horizontal Period	Th	860	1056	1395	Tc	2)
			24.0	26.4	-	μ s	
	Horizontal display period	Thd	800			Tc	
	Vertical Period	Tv	610	628	1024	Th	
	Vertical display period	Tvd	600			Th	
Refresh rate		fv	50	60	70	Hz	3)

- 1) If the display is used under the condition which is out of specifications such as higher clock frequency than specified value, there is a possibility phenomenon such as display error including white display, malfunction and no image may occur. Please use the display under the conditions written in the specification.
- 2) Please set a clock frequency, a vertical blank period, and the horizontal blank period so that the Horizontal Period should not reach less than Min. value.
- 3) If the refresh rate reach less than Min. value, the deterioration of the display quality, flicker etc., may occur. ($fv=1/Tv$)

Vertical Timing Diagram

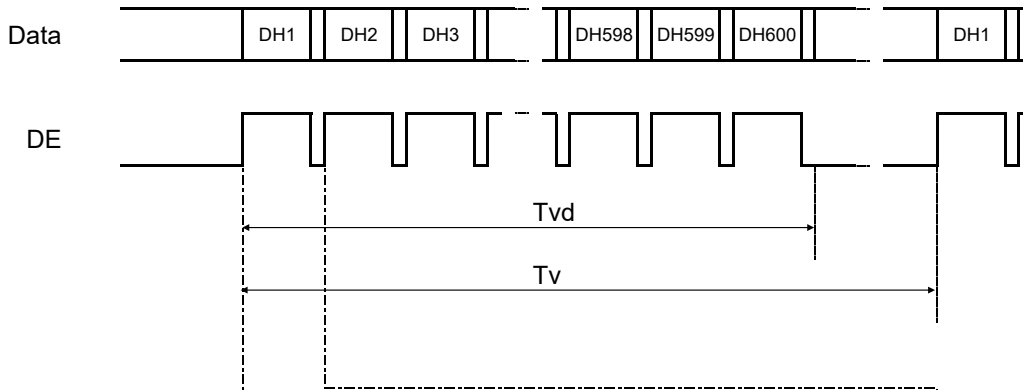

Horizontal Timing Diagram

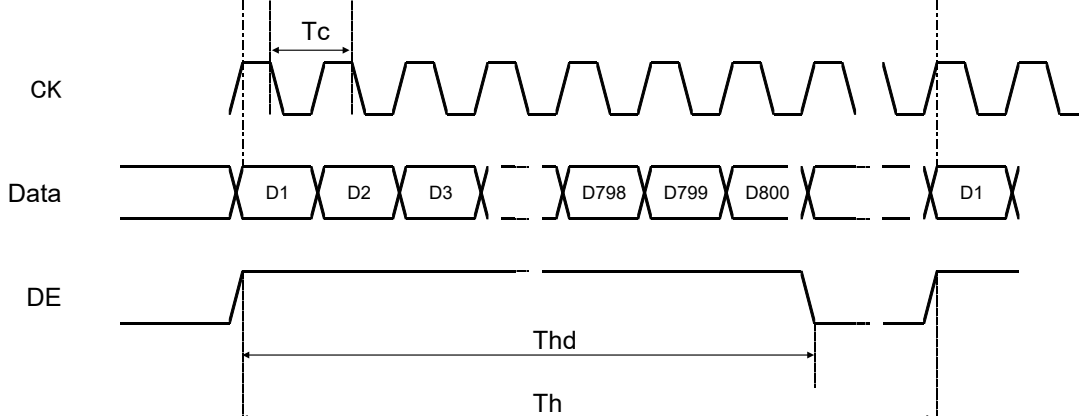

8-2. Input data signals and display position on the screen

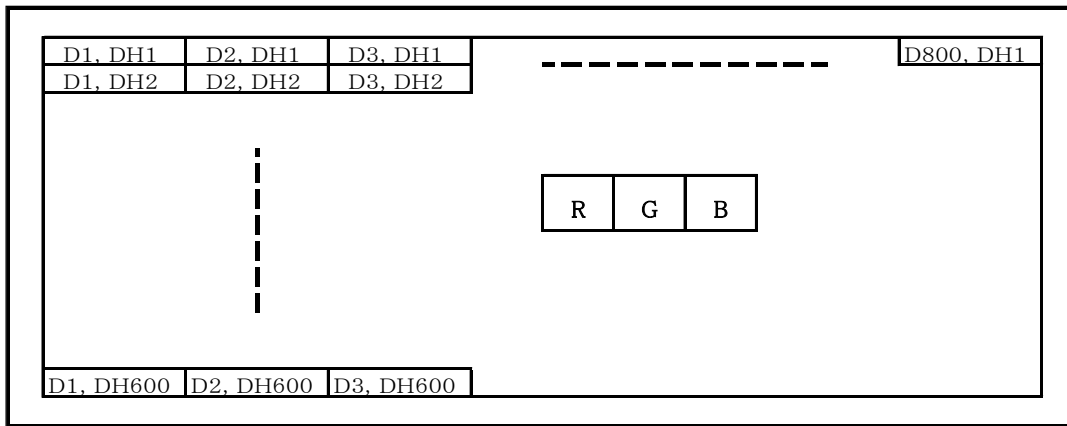

9. Lot number identification

The production lot of module is specified as follows.

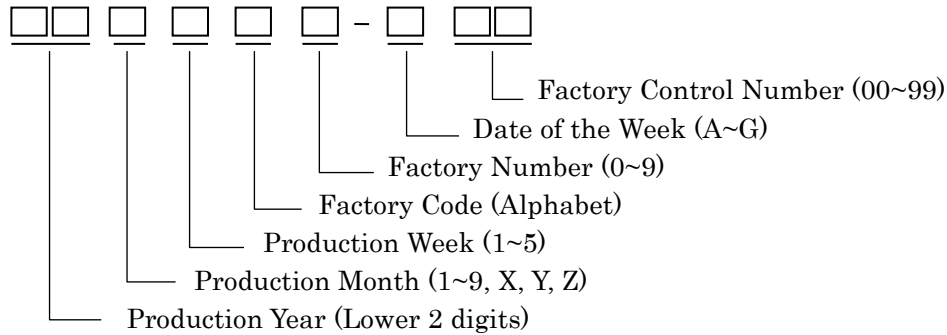

QR code label (For internal control purpose only)

- Character indication contents : Model name, Lot number, Panel ID, Country of origin
- QR code contents : Model name, Panel ID

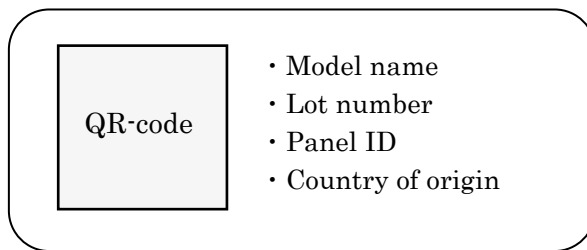

10. Warranty

10-1. Incoming inspection

Please inspect the LCD within one month after your receipt.

10-2. Production warranty

Kyocera warrants the LCDs for a period of 12 months from the ship date. Kyocera shall, by mutual agreement, replace or re-work defective LCDs that are shown to be Kyocera's responsibility.

11. Precautions for use

11-1. Installation of the LCD

- 1) Please ground either of the mounting (screw) holes of LCD, in order to stabilize brightness and display quality.
- 2) A transparent protection plate shall be added to protect the LCD and its polarizer.
- 3) The LCD shall be installed so that there is no pressure on the LSI chips.
- 4) Since this product is wide viewing product, occurrence level of in-plane unevenness by the external stress is different compared to current normal viewing product. So there is a possibility that in-plane unevenness will be occurred by over twist, strain giving by attaching to LCD, and over pressure to touch panel. Please be careful of stress when designing the housing.
- 5) A transparent protection film is attached to the polarizer. Please remove the protection film slowly before use, paying attention to static electricity.

11-2. Static electricity

- 1) Since CMOS ICs are mounted directly onto the LCD glass, protection from static electricity is required.
- 2) Workers should use body grounding. Operator should wear ground straps.

11-3. LCD operation

- 1) The LCD shall be operated within the limits specified. Operation at values outside of these limits may shorten life, and/or harm display images.
- 2) Please select the best display pattern based on your evaluation because flicker, lines or nonuniformity or unevenness can be visible depending on display patterns.

11-4. Storage

- 1) The LCD shall be stored within the temperature and humidity limits specified.
Store in a dark area, and protect the LCD from direct sunlight or fluorescent light.
- 2) Always store the LCD so that it is free from external pressure onto it.

11-5. Usage

- 1) **DO NOT** store in a high humidity environment for extended periods. Polarizer degradation bubbles, and/or peeling off of the polarizer may result.
- 2) The front polarizer is easily scratched or damaged. Prevent touching it with any hard material, and from being pushed or rubbed.
- 3) The LCD screen may be cleaned by wiping the screen surface with a soft cloth or cotton pad using a little Ethanol.
- 4) Water may cause damage or discoloration of the polarizer. Clean condensation or moisture from any source immediately.
- 5) Always keep the LCD free from condensation during testing. Condensation may permanently spot or stain the polarizer.
- 6) Do not disassemble LCD because it will result in damage.
- 7) This Kyocera LCD has been specifically designed for use in general electronic devices, but not for use in a special environment such as usage in an active gas. Hence, when the LCD is supposed to be used in a special environment, evaluate the LCD thoroughly beforehand and do not expose the LCD to chemicals such as an active gas.
- 8) Please do not use solid-base image pattern for long hours because a temporary afterimage may appear. We recommend using screen saver etc. in cases where a solid-base image pattern must be used.
- 9) Liquid crystal may leak when the LCD is broken. Be careful not to let the fluid go into your eyes and mouth. In the case the fluid touches your body; rinse it off right away with water and soap.

12. Reliability test data

Test item	Test condition	Test time	Judgement
High temp. atmosphere	80°C	240h	Display function : No defect Display quality : No defect Current consumption : No defect
Low temp. atmosphere	-30°C	240h	Display function : No defect Display quality : No defect Current consumption : No defect
High temp. humidity atmosphere	40°C 90% RH	240h	Display function : No defect Display quality : No defect Current consumption : No defect
Temp. cycle	-30°C 0.5h R.T. 0.5h 80°C 0.5h	10cycles	Display function : No defect Display quality : No defect Current consumption : No defect
High temp. operation	80°C	500h	Display function : No defect Display quality : No defect Current consumption : No defect
ESD 1), 2)	Contact Discharge 150pF, 330Ω, ±10kV 15mm from A.A. corner, Center (Total 5 points)	10 times each	Display function : No defect Display quality : No defect Current consumption : No defect

- 1) LCD MODULE Power off
- 2) LCD MODULE is not connected to GND.
- 3) Each test item uses a test LCD only once. The tested LCD is not used in any other tests.
- 4) The LCD is tested in circumstances in which there is no condensation.
- 5) The reliability test is not an out-going inspection.
- 6) The result of the reliability test is for your reference purpose only, and the reliability test is conducted only to examine the LCD's capability.

No	Description	Drawn	Checked	Checked	Approved
△	·Add Matching Connector. (適合コネクタ追加)	'21.10.08 蔭山	'21.10.14 張		'21.10.14 宇佐美

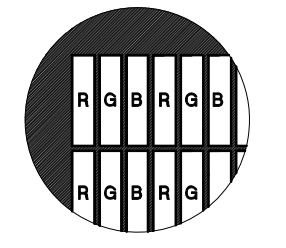
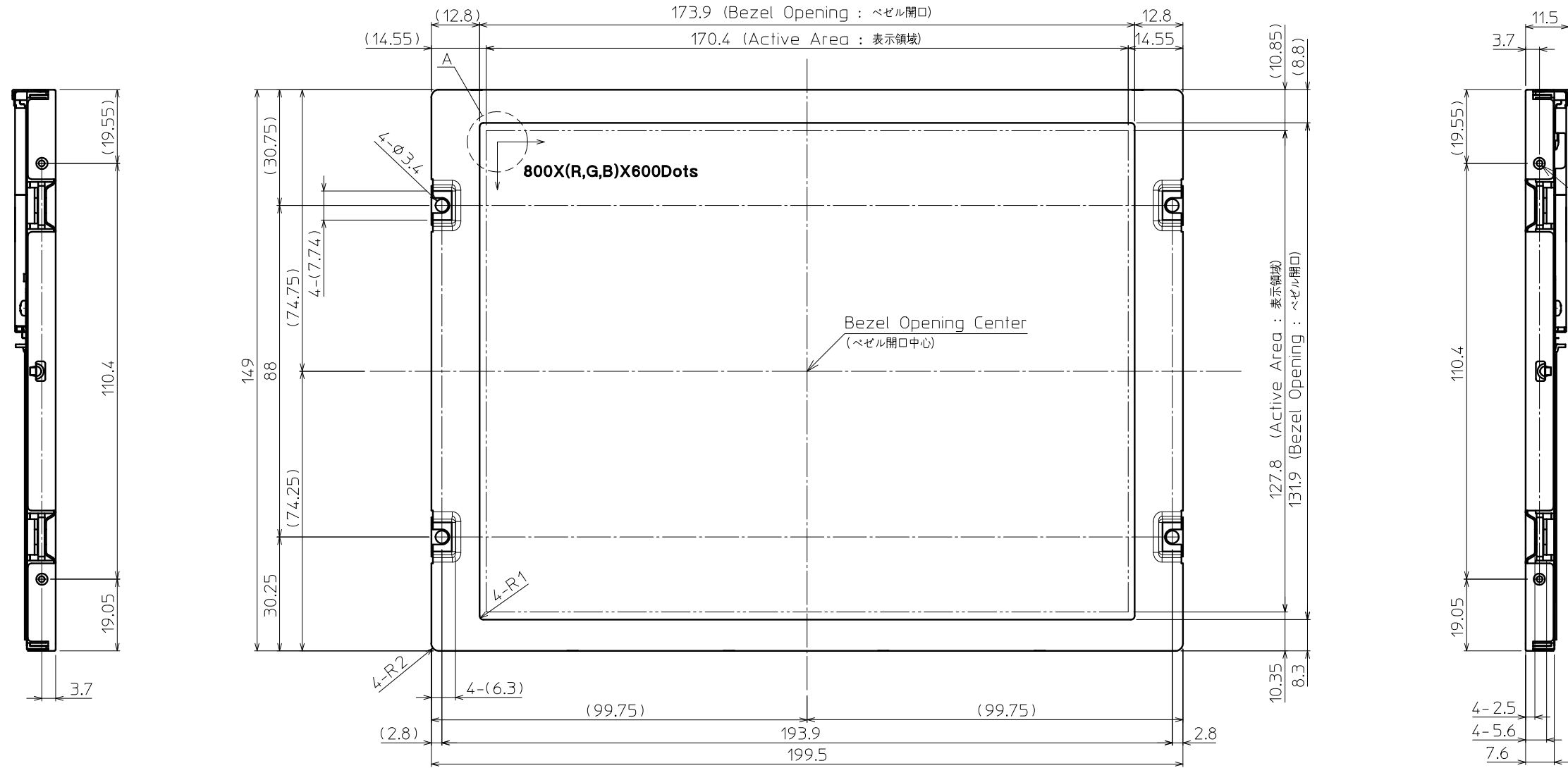



- Note. (注記)
- Connector CN1: FI-X30SSLA-HF (JAE)
(コネクタ)
 - Matching Connector CN1: FI-X30HL,
(適合コネクタ) FI-X30C-NPB,
FI-X30MA1 (JAE)
 - The Information of LCD is displayed starting at the upper left hand corner, moving right then down to the lower right hand corner.
(LCDにおいて、画像データの表示は左上コーナーから始まり、右へ進み下へ送られ右下コーナーへ向かう。)

- Tolerance without indication : ±0.5
(指示無き公差)
- There is a possibility that in-plane unevenness will be occurred by over twist, stress giving by attaching to LCD, and over pressure to touch panel.
Please be careful of stress when designing the housing.
(過度な捻じり(ひずみ)、LCD固定時での応力発生、タッチパネルでの過度な押し圧によっては、パネル面内にムラが発生することがありますので、筐体設計において、事前に十分確認願います。)
- Max screw length : (3mm)
(最大ネジ長)
- Max screw torque : (0.2N·m)
(最大ネジ締め付けトルク)

Material 材質	Treatment 処理	Approved '21.06.11	Checked	Checked '21.06.11	Drawn 蔭山	Scale 1:1	Title TCG084SVLRGVNN	KYOCERA Drawing No. 121A9018400-1	Year-Month-Day '21.06.03	Size 2
Quantity 製作数	Description; 備考	RoHS 17083-08060-3	宇佐美	本間		Outline Dimensions			1/2	

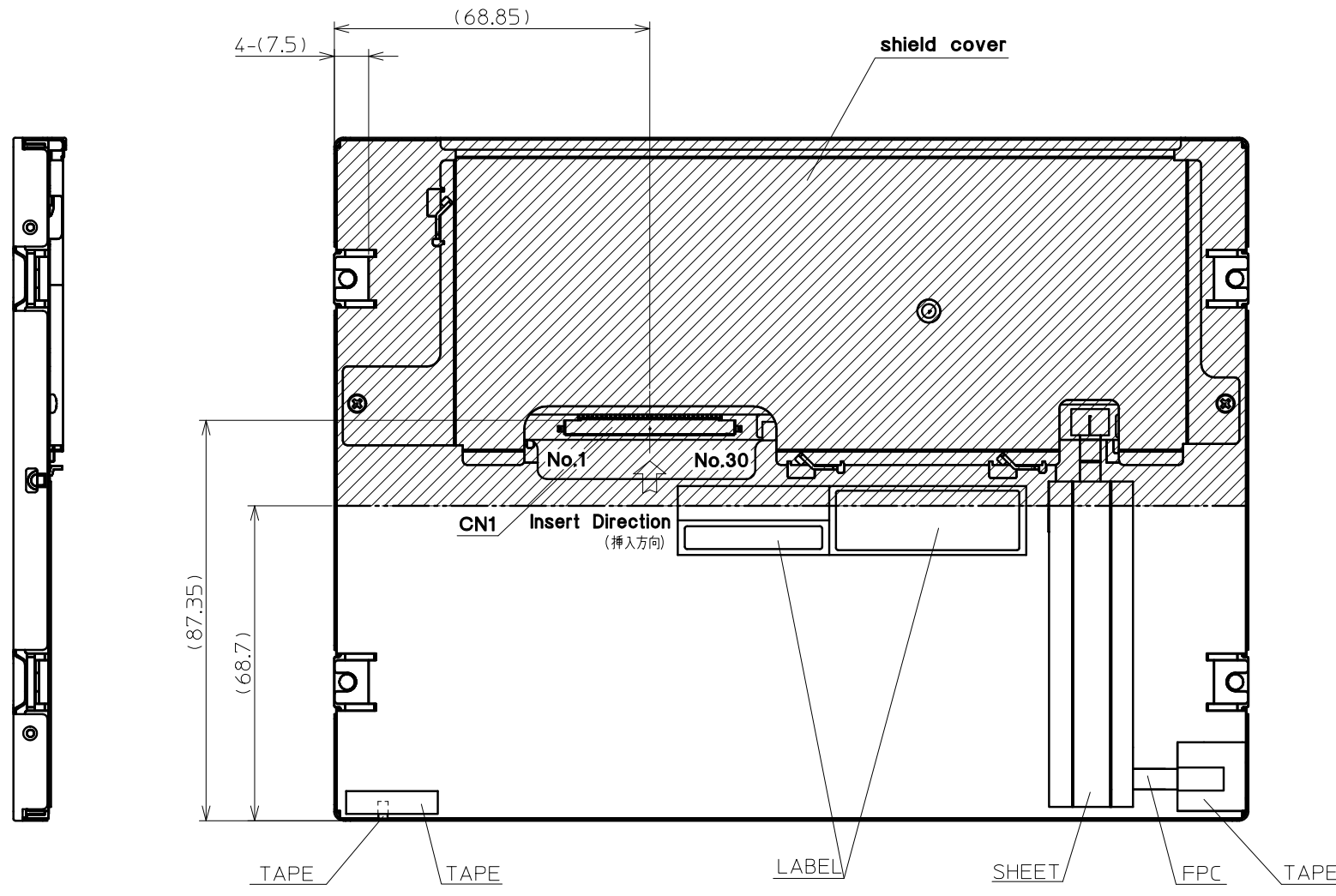
No	Description	Drawn	Checked	Checked	Approved
△	·1/2 Rev.UP	'21.10.08 蔭山	'21.10.14 張		'21.10.14 宇佐美

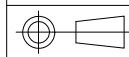

 :Projected part is 11.5mm thickness.
(厚≠11.5mm)

Material 材質	Treatment 処理	Approved '21.06.11 宇佐美	Checked	Checked '21.06.11 本間	Drawn 蔭山	Scale 1:1	Title TCG084SVLRGVNN	 Year-Month-Day '21.06.03 Drawing No. 121A9018400-1	Size 2
Quantity 製作数	Description; 備考 RoHS 17083-08060-3						Outline Dimensions		2 2

Spec No.	TQ3C-8EAF0-E2YAF115-00
Date	September 20, 2023

KYOCERA INSPECTION STANDARD

TYPE : TCG084SVLRGVNN-AN41

KYOCERA CORPORATION

Original Issue Date	Designed by: Engineering dept.			Confirmed by: QA dept.
	Prepared	Checked	Approved	Approved
September 20, 2023	<i>Y. Takakura</i>	<i>T. Fukui</i>	<i>A. Iwasaki</i>	<i>T. Sawada</i>

Spec No.
TQ3C-8EAF0-E2YAF115-00

Part No.
TCG084SVLRGVNN-AN41

Page
-

Revision record

Date		Designed by : Engineering dept.			Confirmed by : QA dept.
		Prepared	Checked	Approved	Approved
Rev. No.	Date	Page	Descriptions		

Visuals specification

1) Note

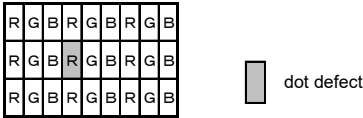
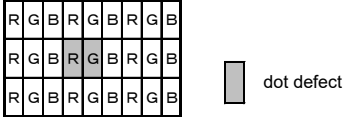
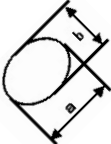
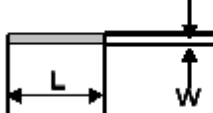
		Note	
General	<p>1. Customer identified anomalies not defined within this inspection standard shall be reviewed by Kyocera, and an additional standard shall be determined by mutual consent.</p> <p>2. This inspection standard about the image quality shall be applied to any defect within the active area and shall not be applicable to outside of the area.</p> <p>3. Inspection conditions</p> <p>Luminance : 500 Lux min.</p> <p>Inspection distance : 300 mm.</p> <p>Temperature : 25 ± 5°C</p> <p>Direction : Directly above</p>		
Definition of inspection item	Dot defect	Bright dot defect	<p>The dot is constantly “on” when power applied to the LCD, even when all “Black” data sent to the screen.</p> <p>Inspection tool: 5% Transparency neutral density filter.</p> <p>Count dot: If the dot is visible through the filter.</p> <p>Don't count dot: If the dot is not visible through the filter.</p> 
		Black dot defect	<p>The dot is constantly “off” when power applied to the LCD, even when all “White” data sent to the screen.</p> <p>Similar size compared to bright dot.</p>
		White dot (Circular/foreign particle)	<p>Pixel works electrically, however, circular/foreign particle makes dot appear to be “on” even when all “Black” data is sent to the screen.</p>
		Dark dot (Circular/foreign particle)	<p>Pixel works electrically, however, circular/foreign particle makes dot appear to be “off” even when all “White” data is sent to the screen.</p>
		Adjacent dot	<p>Adjacent dot defect is defined as two or more bright dot defects or black dot defects.</p> 
	External inspection	Bubble, Scratch, Foreign particle (Polarizer, Cell, Backlight)	Visible operating (all pixels “Black” or “White”) and non operating.
	Appearance inspection		Does not satisfy the value at the spec.
Definition of size	<p>Definition of circle size</p>  <p>a: major axis, b: minor axis</p> <p>$d = (a + b) / 2$</p>	<p>Definition of linear size</p> 	

2) Standard

Classification		Inspection item		Judgement standard																
Defect (in LCD glass)	Single dot	Bright dot defect		Acceptable number	: 4															
		Black dot defect		Bright dot spacing	: 5 mm or more															
	Adjacent dot	2 dots	Bright dot defect	Acceptable number	: 5															
			Black dot defect	Black dot spacing	: 5 mm or more															
		3 or more dots		Acceptable number	: 0															
	Total dot defects		Acceptable number		: 5 Max															
	Others	White dot, Dark dot (Circle)		<table border="1"> <thead> <tr> <th>Size (mm)</th> <th colspan="2">Acceptable number</th> </tr> </thead> <tbody> <tr> <td>$d \leq 0.2$</td> <td colspan="2">(Neglected)</td> </tr> <tr> <td>$0.2 < d \leq 0.4$</td> <td colspan="2">5</td> </tr> <tr> <td>$0.4 < d \leq 0.5$</td> <td colspan="2">3</td> </tr> <tr> <td>$0.5 < d$</td> <td colspan="2">0</td> </tr> </tbody> </table>			Size (mm)	Acceptable number		$d \leq 0.2$	(Neglected)		$0.2 < d \leq 0.4$	5		$0.4 < d \leq 0.5$	3		$0.5 < d$	0
Size (mm)	Acceptable number																			
$d \leq 0.2$	(Neglected)																			
$0.2 < d \leq 0.4$	5																			
$0.4 < d \leq 0.5$	3																			
$0.5 < d$	0																			
External inspection (Defect on Polarizer or between Polarizer and LCD glass)	Polarizer (Scratch)	<table border="1"> <thead> <tr> <th>Width (mm)</th> <th>Length (mm)</th> <th>Acceptable number</th> </tr> </thead> <tbody> <tr> <td>$W \leq 0.1$</td> <td>—</td> <td>(Neglected)</td> </tr> <tr> <td rowspan="2">$0.1 < W \leq 0.3$</td> <td>$L \leq 5.0$</td> <td>(Neglected)</td> </tr> <tr> <td>$5.0 < L$</td> <td>0</td> </tr> <tr> <td>$0.3 < W$</td> <td>—</td> <td>0</td> </tr> </tbody> </table>			Width (mm)	Length (mm)	Acceptable number	$W \leq 0.1$	—	(Neglected)	$0.1 < W \leq 0.3$	$L \leq 5.0$	(Neglected)	$5.0 < L$	0	$0.3 < W$	—	0		
		Width (mm)	Length (mm)	Acceptable number																
		$W \leq 0.1$	—	(Neglected)																
		$0.1 < W \leq 0.3$	$L \leq 5.0$	(Neglected)																
	$5.0 < L$		0																	
	$0.3 < W$	—	0																	
	Polarizer (Bubble)	<table border="1"> <thead> <tr> <th>Size (mm)</th> <th colspan="2">Acceptable number</th> </tr> </thead> <tbody> <tr> <td>$d \leq 0.2$</td> <td colspan="2">(Neglected)</td> </tr> <tr> <td>$0.2 < d \leq 0.3$</td> <td colspan="2">5</td> </tr> <tr> <td>$0.3 < d \leq 0.5$</td> <td colspan="2">3</td> </tr> <tr> <td>$0.5 < d$</td> <td colspan="2">0</td> </tr> </tbody> </table>			Size (mm)	Acceptable number		$d \leq 0.2$	(Neglected)		$0.2 < d \leq 0.3$	5		$0.3 < d \leq 0.5$	3		$0.5 < d$	0		
		Size (mm)	Acceptable number																	
		$d \leq 0.2$	(Neglected)																	
		$0.2 < d \leq 0.3$	5																	
$0.3 < d \leq 0.5$	3																			
$0.5 < d$	0																			
Foreign particle (Circular shape)	<table border="1"> <thead> <tr> <th>Size (mm)</th> <th colspan="2">Acceptable number</th> </tr> </thead> <tbody> <tr> <td>$d \leq 0.2$</td> <td colspan="2">(Neglected)</td> </tr> <tr> <td>$0.2 < d \leq 0.4$</td> <td colspan="2">5</td> </tr> <tr> <td>$0.4 < d \leq 0.5$</td> <td colspan="2">3</td> </tr> <tr> <td>$0.5 < d$</td> <td colspan="2">0</td> </tr> </tbody> </table>			Size (mm)	Acceptable number		$d \leq 0.2$	(Neglected)		$0.2 < d \leq 0.4$	5		$0.4 < d \leq 0.5$	3		$0.5 < d$	0			
	Size (mm)	Acceptable number																		
	$d \leq 0.2$	(Neglected)																		
	$0.2 < d \leq 0.4$	5																		
$0.4 < d \leq 0.5$	3																			
$0.5 < d$	0																			
Foreign particle (Linear shape) Scratch	<table border="1"> <thead> <tr> <th>Width (mm)</th> <th>Length (mm)</th> <th>Acceptable number</th> </tr> </thead> <tbody> <tr> <td>$W \leq 0.03$</td> <td>—</td> <td>(Neglected)</td> </tr> <tr> <td rowspan="2">$0.03 < W \leq 0.1$</td> <td>$L \leq 2.0$</td> <td>(Neglected)</td> </tr> <tr> <td>$2.0 < L \leq 4.0$</td> <td>3</td> </tr> <tr> <td>$0.1 < W$</td> <td>$4.0 < L$</td> <td>0</td> </tr> <tr> <td colspan="2"></td> <td>(According to circular shape)</td> </tr> </tbody> </table>			Width (mm)	Length (mm)	Acceptable number	$W \leq 0.03$	—	(Neglected)	$0.03 < W \leq 0.1$	$L \leq 2.0$	(Neglected)	$2.0 < L \leq 4.0$	3	$0.1 < W$	$4.0 < L$	0			(According to circular shape)
	Width (mm)	Length (mm)	Acceptable number																	
	$W \leq 0.03$	—	(Neglected)																	
	$0.03 < W \leq 0.1$	$L \leq 2.0$	(Neglected)																	
$2.0 < L \leq 4.0$		3																		
$0.1 < W$	$4.0 < L$	0																		
		(According to circular shape)																		
Color variation (Mura)	Not to be significantly visible.																			
	Consultation shall be held as necessary.																			

X-ON Electronics

Largest Supplier of Electrical and Electronic Components

Click to view similar products for [TFT Displays & Accessories](#) category:

Click to view products by [Kyocera Display](#) manufacturer:

Other Similar products are found below :

[OAI-80038AA-2013-A](#) [HDA430T-3G1H](#) [NB-ATT01](#) [NL8060BC26-35C](#) [TCG104SVLQAPNN-AN20](#) [OAI-80038AA-2008-A](#) [315-U004B15300](#) [EIC-LCD-1080P](#) [NL10276BC20-18C](#) [DEM 128160D](#) [TMH-PW-N](#) [RFE43BU-AIW-DNG](#) [EA WF050-40S](#) [EA WF050-40ST](#) [RFC350X-AWW-DNG](#) [RFS390E-AWW-DNN](#) [DEM 480272G2](#) [VMX-PW-N \(A-TOUCH\)](#) [PH800480T013-ICA](#) [DEM 1024600N](#) [VMX-PW-N \(C-TOUCH\)](#) [DEM 1024600P](#) [VMH-PW-N \(C-TOUCH\)](#) [SM-RVT50HQHNWCA0](#) [DEM 240280A](#) [VMH-PW-N](#) [DEM 170320A](#) [VMH-PW-N](#) [PH240320T068-LAB08](#) [DEM 800480T1](#) [TMH-PW-N](#) [PH128128T041-LAA07](#) [PH480272T005-IAC02](#) [DEM 1024600P](#) [VMH-PW-N \(A-TOUCH\)](#) [DEM 800480T1](#) [TMH-PW-N \(C-TOUCH\)](#) [DEM 800480Q4](#) [VMX-PW-N](#) [DEM 800480T1](#) [TMH-PW-N \(A-TOUCH\)](#) [PH320240T-023-I02Q](#) [PH128800T004-ZZA01](#) [RFE430W-1YW-DBS](#) [DEM 1024600N](#) [VMX-PW-N \(A-TOUCH\)](#) [PH240320T074-ZAA01](#) [DEM 480480D](#) [VMX-PW-N \(C-TOUCH\)](#) [SM-RVT50HQSNNWN00](#) [SM-RVT50HQHNWC00](#) [PH800480T033-ICB01](#) [RFE430W-AWW-DNN](#) [DEM 096096A](#) [VMH-PW-N](#) [RL0F00050000FGAAASA01](#) [PH320480T009-LAA01](#) [SM-RVT50HQSNNWCA0](#) [SM-RVT50HQSNNWC00-B](#) [PH320240T028-ZEA01](#) [RFE430W-1YW-DBN](#) [SM-RVT50HQHNWC00-B](#) [DEM 120240A](#) [VMH-PW-N](#) [DEM 268800A](#) [VMH-PW-N](#)