



深圳市凯越翔实业

石英谐振器规格书

| | |
|-----------|-------------------|
| 产品名称: | 石英晶体谐振器 |
| 产品型号: | 49USSMD/16.000MHZ |
| 产品参数: | 12PF/±20ppm |
| 原厂型号: | KBD160001220 |
| 尺寸图: | P. 4 |
| 凯越翔实业技术部: | 董宗全 |

客 户 确 认 栏

| | |
|-------|-------|
| 认证印章 | 负责人印章 |
| 年 月 日 | 年 月 日 |

本规格章程连同本页共 5 页

产品规格书

| | |
|-----------------------------------|--|
| 1.GENERAL | |
| 1.1 HOLDER TYPE | 49USSMD |
| 1.2 MODE OF VIBRATION | AT CUT |
| 1.3 OSCILLATION MODE | FUND |
| 1.4 TEST FACILITIES | S&A KH-1240 |
| 1.5 STORAGE TEMPERATURE | -40℃ TO +85℃ |
| 1.6 DRIVER LEVEL | 100 μ W |
| 2.ELECTRICAL PARAMETER | |
| 2.1 NORMAL FREQUENCY | 16.000MHz |
| 2.2 FREQUENCY TOLERANCE (25℃ ±2℃) | ±20ppm |
| 2.3 TEMPERATURE STABILITY | ±20ppm |
| 2.4 OPERATING TEMPERATURE RANGE | -20℃ TO + 70℃ |
| 2.5 LOAD CAPACITANCE | 12PF |
| 2.6 MOTIONAL CAPACITANCE | |
| 2.7 SHUNT CAPACITANCE | 7PF MAX |
| 2.8 EFFECTIVE SERIES RESISTANCE | 40 Ω MAX |
| 2.9 INSULATION RESISTANCE | 500M OHMS MIN AT DC 100V |
| 3.MECHANICAL PARAMETER | |
| 3.1 SOLDERABILITY | 95%COVERAGE BY USING 90/10 SOLD AT 245℃ FOR 5 SEC. DIPPING AFTER IMMERSION IN ALPHA 611 FLUX FOR 5 SEC. |

| | | | | | | | | | | | | | | | | |
|---|-------|---------------------------------|------|---------|--------------------|-----|--------|---------------|-------|-----------|--------------|------|-------|---------|------|---------------------------------|
| | | | | | | | | | | | | | | | | |
| <p>I MECHANICAL ENDURANCE 机械特性</p> <p>Provided that measurement shall be carried out after letting it alone in the room temperature for 1 hour. 试验产品应在室温下放置 1 小时后方可进行以下试验。</p> <p>①SHOCK 抗击测试</p> <p>Electrical characteristics shall be satisfied after dropping three time from the height of 50 cm onto Hard wooden board . 产品从 50 cm 高度自由落下到硬木板 3 次电气参数仍符合要求。</p> <p>②VIBRATION 抗振测试</p> <p>Electrical characteristics shall be satisfied after supplying following Vibration . 电气性能应满足以下的振动要求。</p> <table border="0"> <tr> <td>(1)VIBRATION FREQUENCY</td> <td>振动频率</td> <td>10—55Hz</td> </tr> <tr> <td>(2)REPEATED PERIOD</td> <td>周 期</td> <td>1—2min</td> </tr> <tr> <td>(3)FULL CYCLE</td> <td>全 振 幅</td> <td>1.5mm P—P</td> </tr> <tr> <td>(4)DIRECTION</td> <td>振动方向</td> <td>X.Y.Z</td> </tr> <tr> <td>(5)TIME</td> <td>振动时间</td> <td>2hours/each direction 2 小时/每个方向</td> </tr> </table> <p>③STRENGTH OF TERMINALS/LEAD—WIRES 引脚与基座底部的强度测试</p> <p>-1 PULLING 拉力测试</p> <p>a)Body of specimen shall be fixed, and 900g of tension weight shall be supplied gradually to axial direction of terminals/lead-wires for 30 sec . 产品应固定在 900g 的拉力的情况下逐渐延基座底部/引线脚中轴方向拉 30 秒钟。</p> <p>b)After above test a), there is no observation of any visual damages on the specimen. 经过 a)的测试, 产品应没有任何可以目测到的损坏。</p> <p>-2 BENDING 弯曲度测试</p> <p>a)Body of specimen shall be fixed, and 90degree bending shall be given, being supplied 225gs tension weight . After that, terminals/lead-wires shall be straightened gradually . Then the same bending and straightening shall be supplied to the opposite direction in the same axial . (Refer to Fig-1) 产品固定后, 以 90° 的弯曲并供以 225g 的拉力, 然后沿同一轴线并与相反的方向 90° 的弯曲及伸直。(产品结构如图 1 所示)</p> <p>b)After above test a), there is no observation of any visual damages on the specimen . 通过 a)测试后, 晶体上应没有任何可以目测到的损坏。</p> | | (1)VIBRATION FREQUENCY | 振动频率 | 10—55Hz | (2)REPEATED PERIOD | 周 期 | 1—2min | (3)FULL CYCLE | 全 振 幅 | 1.5mm P—P | (4)DIRECTION | 振动方向 | X.Y.Z | (5)TIME | 振动时间 | 2hours/each direction 2 小时/每个方向 |
| (1)VIBRATION FREQUENCY | 振动频率 | 10—55Hz | | | | | | | | | | | | | | |
| (2)REPEATED PERIOD | 周 期 | 1—2min | | | | | | | | | | | | | | |
| (3)FULL CYCLE | 全 振 幅 | 1.5mm P—P | | | | | | | | | | | | | | |
| (4)DIRECTION | 振动方向 | X.Y.Z | | | | | | | | | | | | | | |
| (5)TIME | 振动时间 | 2hours/each direction 2 小时/每个方向 | | | | | | | | | | | | | | |



④ SEALING TIGHTNESS 气密性测试

There is no observation of gas bubble after specimen put in hot water at +90°C—+95°C for 5 min .

晶体置于+90°C—+95°C的热水中 5 分钟，应没有气泡产生。

⑤ SOLDERING DIP 浸锡测试

Terminals/lead-wires of specimen shall be dipped into solder melted tank at +230°C—±5°C for 3sec . Dipping depth shall be 2mm from the bottom of specimens body . (After applying ROSIN flux) Soldering portion shall be covered in over 90% of terminals/lead-wires dipped .

将晶体引线脚置于+230°C—±5°C的锡桶中 3 分钟，基座底部离锡表面 2mm，（加上松香焊剂后）引线脚的沾锡率为 90%以上。

⑥ SOLDER HEATING 沾锡耐热性测试

Terminals/lead-wires of specimen shall be dipped into solder melted tank at

+350°C—±10°C for $\frac{1}{3}$ ₋₀ sec .

Electrical characteristics shall be satisfied after dipping depth shall be 2mm from edge of terminals/lead-wires .

将已沾锡的产品的引线脚置于+350°C—±10°C的锡桶中 3-4 秒钟后 基座底部离锡表面 2mm，电气性能仍符合要求。

II ENVIRONMENTAL ENDURANCE 环境特性

Provided that measurement shall be carried out after letting it alone in the room temperature for 1 hour .

必须将试验产品在室温下放置 1 小时后方可进行测试。

①HUMIDITY 耐湿测试

Electrical characteristics shall be satisfied after letting it alone at 60°C—±2°C in humidity of 90—95% for 250 hours .

试验产品在温度为 60°C—±2°C，相对湿度 90—95%的试验箱内放置 250 小时后电气性能仍符合要求。

②STORAGE IN LOW TEMPERATURE 低温储存测试

Electrical characteristics shall be satisfied after letting it alone at -30°C—±2°C for 250 hours .

试验产品在温度为-30°C—±2°C的试验箱中放置 250 小时后电气性能仍符合要求。

③STORAGE IN HIGH TEMPERATURE 高温储存测试

Electrical characteristics shall be satisfied after letting it alone at +85°C—±2°C for 250 hours .

试验产品在温度为+85°C—±2°C的试验箱中放置 250 小时后电气性能仍符合要求。

④TEMPERATURE CYCLE 温度变换测试

Electrical characteristics shall be satisfied after supplying the following temperature cycle (3cycles) .

Temperature shift from low to high, high to low shall be done in 1°C/min (Refer to Fig-2) .

电气性能应满足以下温度周期要求（3 个周期）

温度变换从低到高，从高到低变化量为 1°C/分。（如图 2 所示）

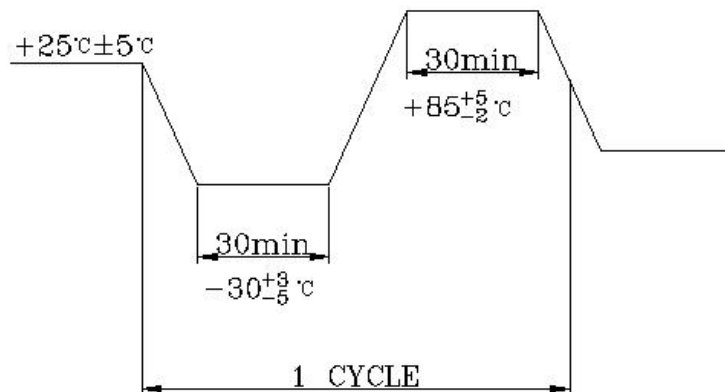

PIG — 2

| | | | | | |
|-----|-----|-----|-----|-----|-----|
| 拟 制 | 成望生 | 审 核 | 董宗全 | 批 准 | 赵庸桓 |
|-----|-----|-----|-----|-----|-----|

X-ON Electronics

Largest Supplier of Electrical and Electronic Components

Click to view similar products for [Crystals](#) category:

Click to view products by [KYX](#) manufacturer:

Other Similar products are found below :

[CX3225GB25000M0PPSZ1](#) [718-13.2-1](#) [MC405](#) [32.0000K-R3:PURE SN](#) [7A-40.000MAAE-T](#) [FL2000085](#) [99-BU](#) [9B-15.360MBBK-B](#) [9C-7.680MBBK-T](#) [H10S-12.000-18-EXT-TR](#) [ABC2-6.000MHZ-D4Z-T](#) [ABLS-20.000MHZ-D2-T](#) [ABS071-32.768KHZ-6-T](#) [R38-32.768-12.5-5PPM-NPB](#) [BTD1062E05A-513](#) [21U15A-21.4MHZ](#) [RTX-781DF1-S-20.950](#) [LFXTAL066198Cutt](#) [9C-14.31818MBBK-T](#) [A-11.000MHZ-27](#) [ABL-27.000MHZ-B4Y-T](#) [ABM11-132-24.000MHZ-T3](#) [ABM3B1-25.000MHZ-D2Y-T](#) [SPT2A-.032768B](#) [SPT2A.032768G](#) [SSPT7F-9PF20-R](#) [FX325BS-38.88EEM1201](#) [LFXTAL065253Cutt](#) [LFXTAL066431Cutt](#) [XT9S20ANA14M7456](#) [XT9SNLANA16M](#) [646G-24-2](#) [7A-24.576MBBK-T](#) [7B-30.000MBBK-T](#) [7A-14.31818MBBK-T](#) [6504-202-1501](#) [6526-202-1501](#) [ABLS-12.000MHZ-B2Y-T](#) [7A-10.000MBBK-T](#) [SG636PCE-20.000MC](#) [3404](#) [E1SAA18-25.000M TR](#) [CM315D32768EZFT](#) [C1E-24.000-7-2020-R](#) [C1E-19.200-12-1530-X-R](#) [C1E-16.000-12-1530-X-R](#) [ABM11-16.000MHZ-9-B1U-T](#) [FL5000014](#) [EUCA18-3.1872M](#) [FX0800015](#) [425F35E027M0000](#)