



深圳市凯越翔电子有限公司

石英谐振器规格书

产品名称:	石英晶振谐振器
产品型号:	MC-306/32.768KHZ
产品参数:	12.5PF/±20ppm
原厂型号:	KMA3276812520
凯越翔技部:	董宗全

客户确认印栏

认证印章	负责人印章
年 月 日	年 月 日

本规格章程连同本页共 6 页

工厂地址: 深圳市龙华区观澜人民路蔡发工业城 1 栋 4 层, TEL: 0755-89315823 89315866
FAX:0755-89315223 官网: www.kaiyuexiang.com

承 认 书
SPECIFICATION FOR APPROVAL

Customer Name : _____

Customer Part No : _____

Product Name : TUNING FORK CRYSTAL _____

Part Description : MC-306 **32.768KHZ** **12.5PF** **±20PPM** ROHS _____

Date : _____

CUSTOMER APPROVED BY

- 1.ELECTRIC CHARAC:**
- 1. Frequency: **32.768** KHZ
 - 2. Holder Type: MC306
 - 3. Frequency Tolerance: **±20**ppm at 25°C ±5°C
 - 4. Equivalent Series Resistance: **70** KΩ Max
 - 5. Storage Temperature Range: -40°C T0 + 85°C
 - 6. Operating Temperature Range: -40°C T0 + 85°C
 - 7. Frequency Characteistics Over Temperatnre:
±20ppm -40°C T0 +85°C
 - 8. Load Capacitance (CL): **12.5** PF
 - 9. Drive Level: 1.0uW MAX
 - 10. Shunt Capacitance: 1.35PF MAX
 - 11. Insulation Resistance: 500MΩ Min at D. C. 100 V

12. Capacitance ratio

650 max

13. Aging:

 ± 5 ppm/Year

14. Marking

32.768

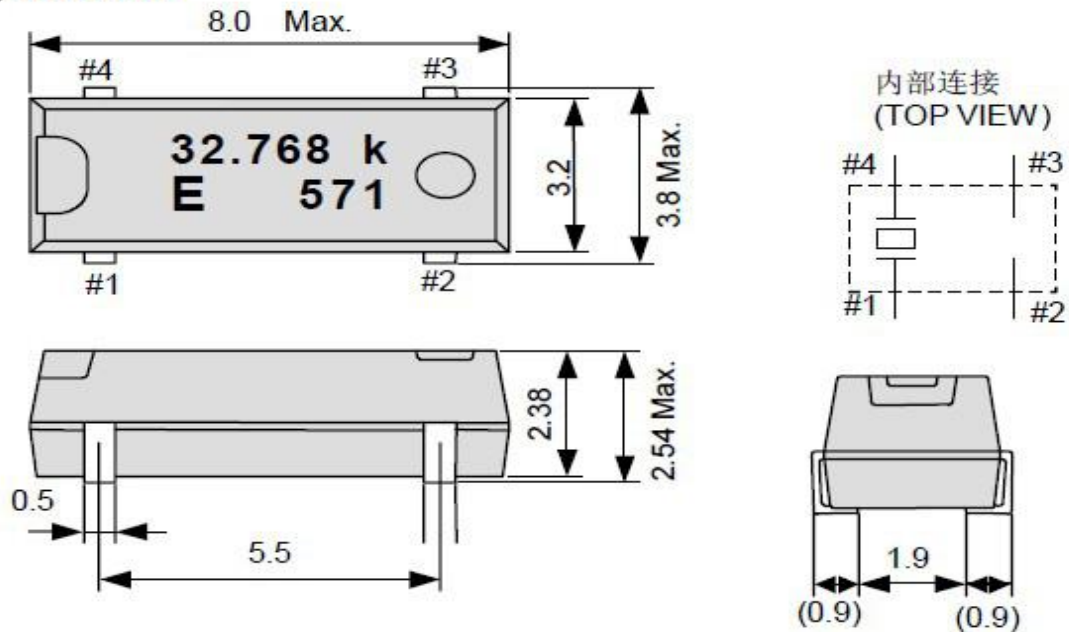
2.DIMENSION (MM)**● MC-306**

请勿连接#2 与#3 到外部器件。

在该产品顶部或底部可能暴露着金属材料。但这不影响任何规格性能。

3. PHYSICAL AND ENVIRONMENTAL CHARACTERISTICS**3-1. Humidity**

Subject the crystal at $40^{\circ}\text{C} \pm 2^{\circ}\text{C}$ and 90% - 95% RH for 96 ± 4 hours

Then release the crystal into the room conditions for 1hour prior to the measurement .

3-2. High Temperature Exposure

Subject the crystal to $85^{\circ}\text{C} \pm 5^{\circ}\text{C}$ for 96 ± 4 hours . Then release the

crystal into the room conditions for 1hour prior to the measurement .

3-3. Low Temperature

Subject the crystal to $-20^{\circ}\text{C} \pm 5^{\circ}\text{C}$ for 96 ± 4 hours . Then release the

crystal into the room conditions for 1hour prior to the measurement

3-4. Mechanical Shock

Drop the crystal randomly onto a concrete floor from the height of 75cm 3 times .

3-5. Temperature Cycling

Subject the crystal to -30°C for 30 min. followed by a high temperature of +85°C for 30 min. Cycling shall be repeated 5times with a transfer time of 15sec. at the room condition . Then release the resonator into the room temperature for 2hours prior to the measurement .

3-6. Vibration

Subject the crystal to vibration for 2hours each in x, y, and z axes with the amplitude of 1.5mm, the frequency shall be varied uniformly between the limits of 10-55 Hz .

3-7. Resistance to Solder Heat

Dip the crystal terminals no closer than 2 mm into the solder bath 260°C±5°C for 5±1 sec; Then release the crystal into the room temperature for 1hour prior to the measurement .

3-8. Solder Ability

Dip the crystal terminals no closer than 2 mm into the solder bath at 235°C± 5°C for 3±0.5 sec .more than 95% of the erminal surface of the crystal shall be covered with fresh solder.

3-9. Lead Fatigue

1) Pulling Test

Weight along with the direction of terminals without any shock 0.5kg for 10±1sec.; The crystal shall no evidence of damage and shall fulfill all the initial electric characteristics。

2) Bending Test

Lead shall be subject to withstand against 90 degree bending at its stem. This operation shall be done towards both direction; The crystal shall no evidence of damage and shall fulfill all the initial electric characteristics。

4. REVIEW OF SPECIFICATION

When something get doubtful with this specifications, we shall jointly work to get an agreement。

拟制	成望生	审核	董宗全	批准	谢为亮
----	-----	----	-----	----	-----

X-ON Electronics

Largest Supplier of Electrical and Electronic Components

Click to view similar products for [Crystals](#) category:

Click to view products by [KYY](#) manufacturer:

Other Similar products are found below :

[CX3225GB25000M0PPSZ1](#) [718-13.2-1](#) [7A-40.000MAAE-T](#) [FL2000085](#) [99-BU](#) [9B-15.360MBBK-B](#) [9C-7.680MBBK-T](#) [H10S-12.000-18-EXT-TR](#) [ABC2-6.000MHZ-D4Z-T](#) [ABLS-20.000MHZ-D2-T](#) [ABS071-32.768KHZ-6-T](#) [R38-32.768-12.5-5PPM-NPB](#) [BTD1062E05A-513](#) [21U15A-21.4MHZ](#) [RTX-781DF1-S-20.950](#) [LFXTAL066198Cutt](#) [9C-14.31818MBBK-T](#) [A-11.000MHZ-27](#) [ABL-27.000MHZ-B4Y-T](#) [ABM11-132-24.000MHZ-T3](#) [ABM3B1-25.000MHZ-D2Y-T](#) [SPT2A-.032768B](#) [SPT2A.032768G](#) [LFXTAL065253Cutt](#) [LFXTAL066431Cutt](#) [XT9S20ANA14M7456](#) [XT9SNLANA16M](#) [7A-24.576MBBK-T](#) [7B-30.000MBBK-T](#) [CX2520DB16000H0HPQCC](#) [MMCC2R32.7680KHZ](#) [6504-202-1501](#) [6526-202-1501](#) [ABLS-12.000MHZ-B2Y-T](#) [7A-10.000MBBK-T](#) [SG636PCE-20.000MC](#) [3404](#) [CM315D32768EZFT](#) [C1E-24.000-7-2020-R](#) [C1E-19.200-12-1530-X-R](#) [C1E-16.000-12-1530-X-R](#) [ABM11-16.000MHZ-9-B1U-T](#) [FL5000014](#) [EUCA18-3.1872M](#) [FX0800015](#) [425F35E027M0000](#) [FP0800018](#) [MS3V-T1R-32.768kHz-7pF-20PPM-TA-QC-Au](#) [VXM7-1C1-16M000](#) [MS3V-T1R-32.768kHz-9pF-20PPM-TA-QC-Au](#)