

**PHYSICAL DIMENSIONS:**

A	11.05	[.435]	+ 0.13	[.005]
B	10.03	[.395]	+ 0.15	[.006]
B <sub>1</sub>	11.05	[.435]	MAX	
C	9.32	[.367]	+ 0.15	[.006]
C <sub>1</sub>	10.49	[.413]	MAX.	
D	4.06	[.160]	+ 0.13	[.005]
E	2.54	[.100]	+ 0.13	[.005]

**WIRE:**

T <sub>1</sub>	3.56	[.140]	+ 0.25	[.010]
T <sub>2</sub>	0.76	[.030]	TYP.	
T <sub>3</sub>	0.76	[.030]	TYP.	

# CM4440Z111R-10

**UNCONTROLLED DOCUMENT**

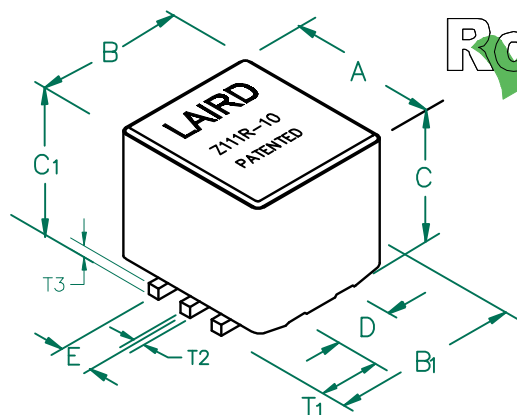

**ELECTRICAL CHARACTERISTICS:**

Z @ 100MHz (Ω)	DCR (Ω)	Rated Current
Nominal	110	
Minimum	83	
Maximum	-	.001
		20,000mA

NOTES: UNLESS OTHERWISE SPECIFIED

1. TAPED AND REELED per CURRENT EIA SPECIFICATIONS 13" REELS, 375 PCS/REEL, EMBOSSED PLASTIC TAPE.
2. COMPONENTS SHOULD BE ADEQUATELY PREHEATED BEFORE SOLDERING.
3. TERMINATION FINISH IS 100% TIN.
4. THIS PART HAS NO PIN POLARITY.

Z vs. FREQUENCY (C,N,O)

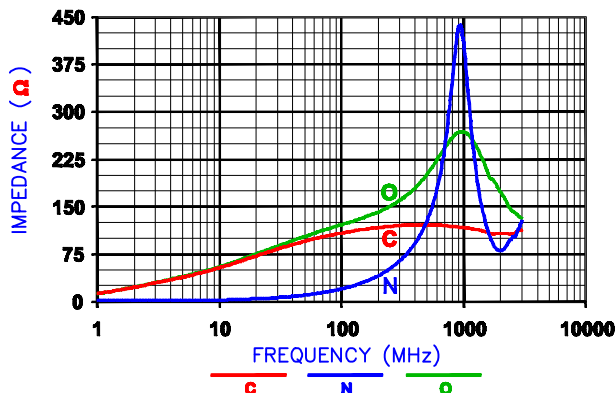

Z, R, XL vs. FREQUENCY

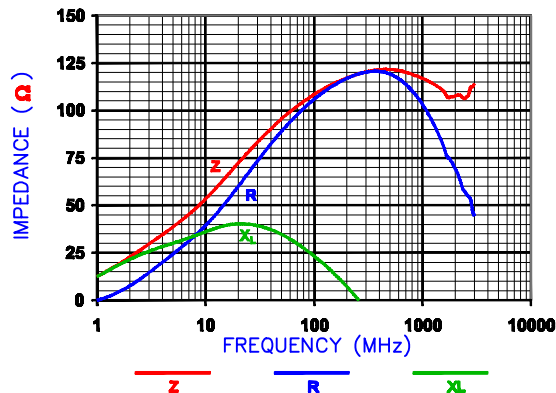

**LAND PATTERNS FOR REFLOW SOLDERING**

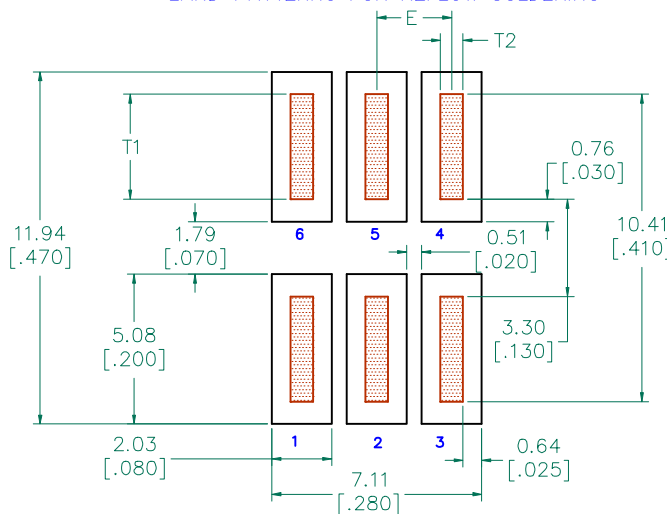

**RECOMMENDED SOLDERING CONDITIONS**

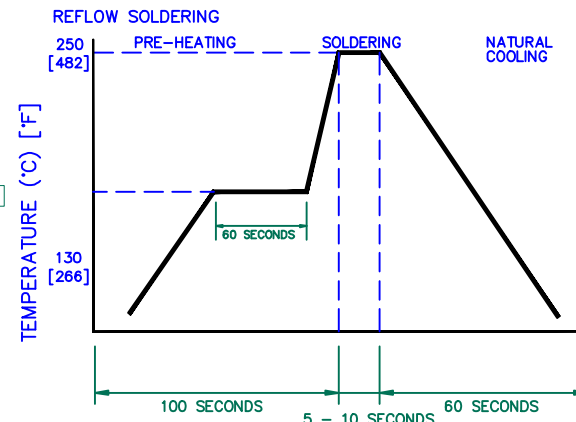

**EQUIVALENT CIRCUIT**

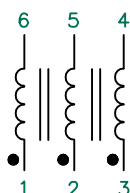

DIMENSIONS ARE IN mm [INCHES].

This print is the property of Laird Tech. and is loaned in confidence subject to return upon request and with the understanding that no copies shall be made without the written consent of Laird Tech. All rights to design or invention are reserved.



PROJECT/PART NUMBER:		REV		PART TYPE:		DRAWN BY:	
CM4440Z111R-10		B		ASSEMBLY		TMB	
B	UPDATE COMPANY LOGO & KAPTON LABEL	11/12/08	JRK	DATE:	12/07/07	SCALE:	NTS
A	ORIGINAL DRAFT	12/07/07	TMB	CAD #	CM4440Z111R-10-B-2	SHEET:	2 of 3
REV	DESCRIPTION	DATE	INT				

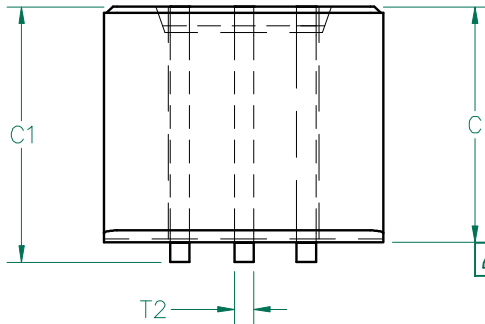
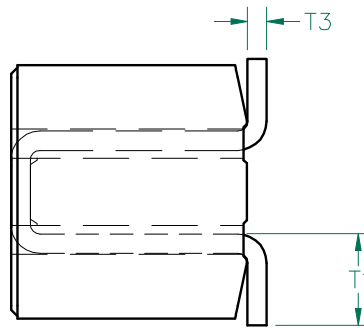
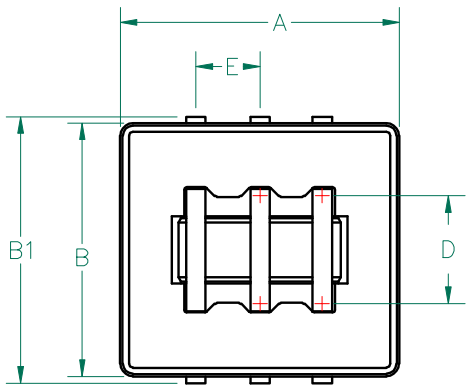

0.10 (.004)  
SEATING PLANE  
(CO-PLANARITY)

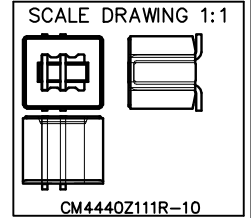

**ELECTRICAL TESTING**

TEST:	GROSS	GROSS
	Z	Z
# TURNS	1	1
AWG	22	22
FREQUENCY	25 MHz	100 MHz
NOMINAL	- Ω	110 Ω
MINIMUM	- Ω	83 Ω

WEIGHT/1000 4.42 kgs. 9.75 lbs.



**UNCONTROLLED DOCUMENT**

NOTES: UNLESS OTHERWISE SPECIFIED

1. WIRE: REFERENCE STEWARD WIRE PURCHASE SPEC. W0040-61.
2. IMPEDANCE VALUES ARE GROSS, MEASURED USING W0040-61 WIRE PLACED AGAINST END OF SLOT w/ NO D.C. BIAS.
3. REFERENCE STEWARD CORE 24H0435-200.
4. NO MORE THAN 0.18 [.007] DIFFERENCE FROM THE LONGEST TO THE SHORTEST CONDUCTOR ON ONE SIDE.
5. TERMINATION FINISH IS 100% TIN.
6. THIS PART HAS NO PIN POLARITY.

**DIMENSIONS:**

A	11.05 [.435]	+ 0.13 [.005]
B	10.03 [.395]	+ 0.15 [.006]
B <sub>1</sub>	11.05 [.435]	MAX
C	9.32 [.367]	+ 0.15 [.006]
C <sub>1</sub>	10.49 [.413]	MAX.
D	4.06 [.160]	+ 0.13 [.005]
E	2.54 [.100]	+ 0.13 [.005]

**WIRE DIMENSIONS:**

T <sub>1</sub>	3.56 [.140]	+ 0.25 [.010]
T <sub>2</sub>	0.76 [.030]	TYP.
T <sub>3</sub>	0.76 [.030]	TYP.

DIMENSIONS ARE IN mm [INCHES].				This print is the property of Laird Tech. and is loaned in confidence subject to return upon request and with the understanding that no copies shall be made without the written consent of Laird Tech. All rights to design or invention are reserved.			
PROJECT/PART NUMBER:				REV	PART TYPE:	DRAWN BY:	
CM4440Z111R-10				B	ASSEMBLY	TMB	
B	UPDATE COMPANY LOGO & KAPTON LABEL	11/12/08	JRK	DATE:	12/07/07	SCALE:	3.5:1
A	ORIGINAL DRAFT	12/07/07	TMB	CAD #	CM4440Z111R-10-B-3	TOOL #	-
REV	DESCRIPTION	DATE	INT	SHEET: 3 of 3			



## X-ON Electronics

Largest Supplier of Electrical and Electronic Components

*Click to view similar products for [Common Mode Chokes / Filters](#) category:*

*Click to view products by [Laird](#) manufacturer:*

Other Similar products are found below :

[PE-64683](#) [RD5122-6-9M6](#) [RGCMF1210900H3T](#) [ST6118T-R](#) [FE3X025-10-7NL](#) [T8114NLT](#) [TCM0806G-350-2P-T](#) [TCM0806G-650-2P-T](#)  
[IND-0110](#) [UAL21VR0802000](#) [UALSC023000000](#) [UALSC1020JH000](#) [UALSU10VR15019](#) [UALSU9VD070100](#) [36-00037](#) [5701610000](#)  
[UALW21HS072450](#) [UALSU9HF050500](#) [UALSU9H0208000](#) [UAL24VK06450CH](#) [PLT10HH501100PNB](#) [PLT10HH401100PNB](#)  
[PLT10HH1026R0PNB](#) [PE-67531](#) [TLH10UB](#) [113 OR5](#) [2752045447](#) [CM8663Z161B-10](#) [7351V](#) [CMF16-153131](#) [T8116NLT](#) [CMS2-10-R](#)  
[FE2X10-4-2NL](#) [T8003NLT](#) [CTX66-19521-R](#) [RC212-0.5-10M](#) [RC112-0.4-15M](#) [RC212-0.6-6M8](#) [RC212-0.4-15M](#) [RC112-0.3-30M](#) [4534-3](#)  
[WTCF2012Z0M751PB](#) [PH9408.814NLT](#) [B82498B3221J000](#) [PAC6006.364NLT](#) [PAC6006.444NLT](#) [PAC6006.204NLT](#) [PH9407.204NLT](#)  
[PAC6006.264NLT](#) [PH9408.105NLT](#) [PH9408.494NLT](#)