

PHYSICAL DIMENSIONS:

A	11.38 [.448]	± 0.18 [.007]
B	11.38 [.448]	± 0.18 [.007]
B1	14.10 [.555]	MAX
C	9.32 [.367]	± 0.18 [.007]
C1	10.16 [.400]	MAX
D	7.62 [.300]	± 0.10 [.004]
E	2.54 [.100]	± 0.13 [.005]

T ₁	2.90 [.114]	± 0.25 [.010]
T ₂	0.84 [.033]	TYP.
T ₃	0.46 [.018]	TYP.

CM4545Z131R-10

UNCONTROLLED DOCUMENT

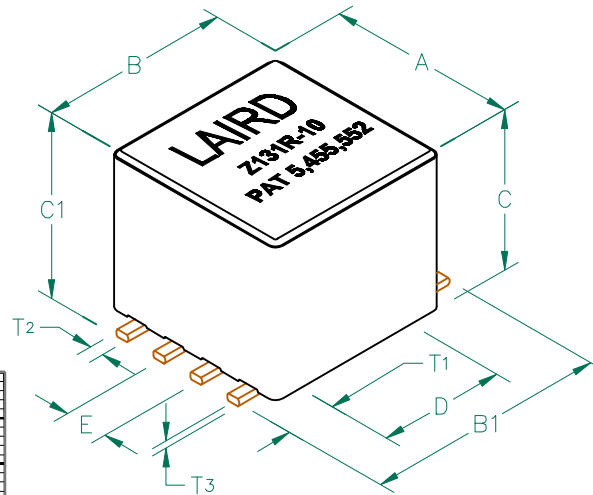

ELECTRICAL CHARACTERISTICS:			
Z @ 100MHz (Ω)	DCR (Ω)	Rated Current	Rated Voltage (VDC)
Nominal	130		
Minimum	98		
Maximum	163	0.01	10,000 mA
			140

NOTES: UNLESS OTHERWISE SPECIFIED

1. TAPED AND REELED per CURRENT EIA SPECIFICATIONS 13" REELS, 400 PCS/REEL.
2. COMPONENTS SHOULD BE ADEQUATELY PREHEATED BEFORE SOLDERING.
3. REF. CARRIER TAPE SPECIFICATION CART449-63.
4. TERMINATION FINISH IS 100% TIN.
5. THIS PART HAS NO PIN POLARITY.
6. OPERATION TEMPERATURE (INCLUDING SELF-HEATING): -40 ~ +125°C.

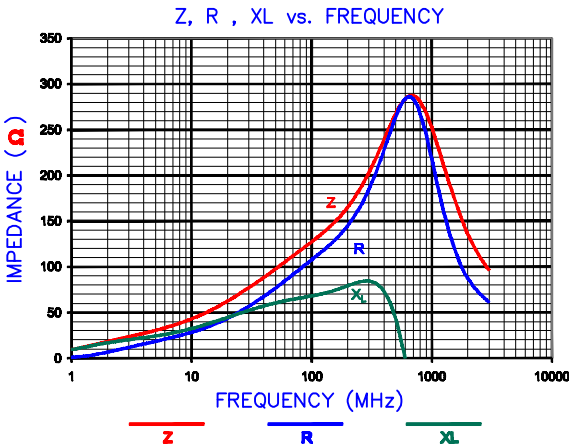
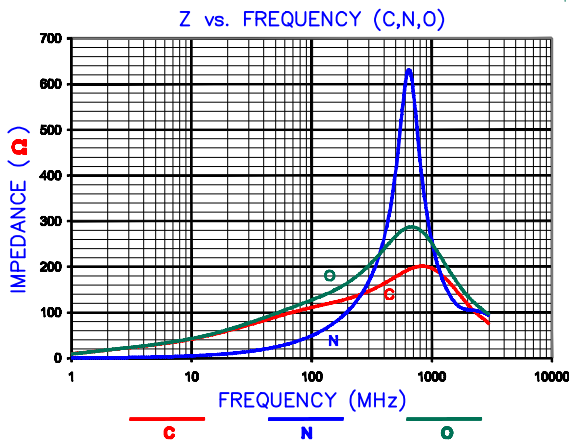

LAND PATTERN FOR REFLOW SOLDERING

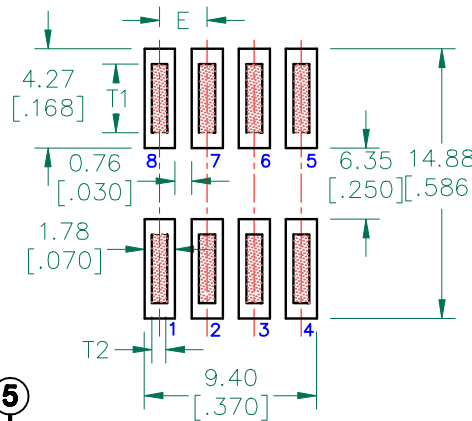

RECOMMENDED SOLDERING CONDITIONS

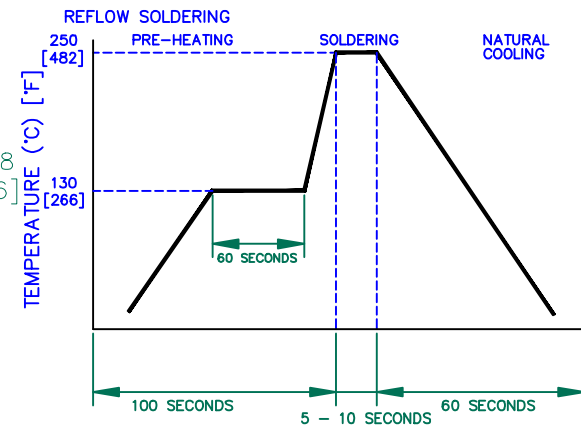

EQUIVALENT CIRCUIT

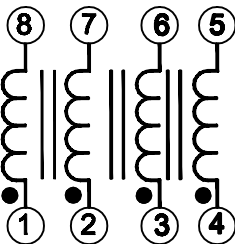

DIMENSIONS ARE IN mm [INCHES].				This print is the property of Laird Tech. and is loaned in confidence subject to return upon request and with the understanding that no copies shall be made without the written consent of Laird Tech. All rights to design or invention are reserved.	
D	ADD RATED VOLTAGE AND NOTE 6	08/30/12	QIU	PROJECT/PART NUMBER:	REV
C	UPDATE LOGO & KAPTON LABEL ADD EC	11/11/08	JRK	CM4545Z131R-10	D
B	UPDATE COMPANY LOGO	12/10/07	JRK	DATE:	06/02/04
A	ORIGINAL DRAFT	06/02/04	JRK	SCALE:	NTS
REV	DESCRIPTION	DATE		CAD #	CM4545Z131R-10-D-2
				TOOL #	H0449-600
				SHEET:	2 of 3

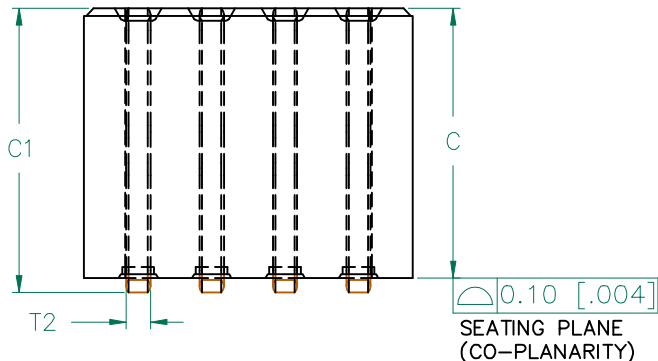
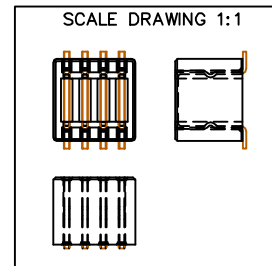
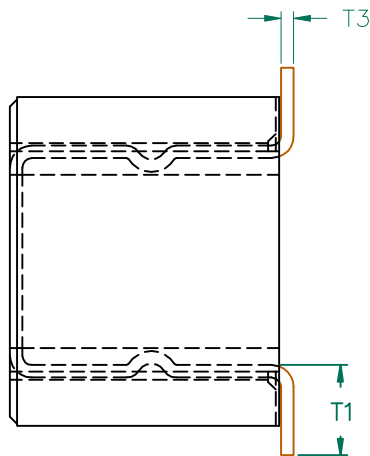
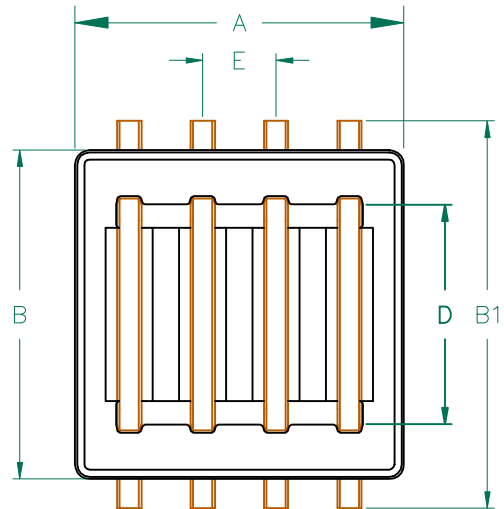

LAIRD
Z131R-10
PAT 5,455,552

LABEL

UNCONTROLLED DOCUMENT

ELECTRICAL TESTING

TEST:	Z	Z
# TURNS	1	1
AWG	22	22
FREQUENCY	25 MHz	100 MHz
NOMINAL	70 Ω	130 Ω
MINIMUM	53 Ω	98 Ω
MAXIMUM	- Ω	163 Ω
WEIGHT/1000	5.13 kgs.	11.32 lbs.

NOTES: UNLESS OTHERWISE SPECIFIED

1. WIRE: REFERENCE STEWARD WIRE PURCHASE SPEC. W0449-61.
2. IMPEDANCE VALUES ARE GROSS, MEASURED USING W0449-61 WIRE PLACED AGAINST END OF SLOT w/ NO D.C. BIAS.
3. REFERENCE STEWARD CORE P/N 29H0449-600.
4. PROTECTED BY U.S. PATENT NO. 5,455,552.
5. TERMINATION FINISH IS 100% TIN.
6. THIS PART HAS NO PIN POLARITY.

DIMENSIONS:

A	11.38 [.448]	+	0.18 [.007]
B	11.38 [.448]	+	0.18 [.007]
B1	14.10 [.555]	+	MAX
C	9.32 [.367]	+	0.18 [.007]
C1	10.16 [.400]	+	MAX
D	7.62 [.300]	+	0.10 [.004]
E	2.54 [.100]	+	0.13 [.005]

WIRE DIMENSIONS:

T1	2.90 [.114]	+	0.25 [.010]
T2	0.84 [.033]	+	TYP.
T3	0.46 [.018]	+	TYP.



DIMENSIONS ARE IN mm [INCHES].				This print is the property of Laird Tech. and is loaned in confidence subject to return upon request and with the understanding that no copies shall be made without the written consent of Laird Tech. All rights to design or invention are reserved.	
D	ADD RATED VOLTAGE AND NOTE 6	08/30/12	QIU	PROJECT/PART NUMBER:	REV
C	UPDATE LOGO & KAPTON LABEL ADD EC	11/11/08	JRK	CM4545Z131R-10	D
B	UPDATE COMPANY LOGO	12/10/07	JRK	DATE: 06/02/04	SCALE: NTS
A	ORIGINAL DRAFT	06/02/04	JRK	GAD #	SHEET: 3 of 3
REV	DESCRIPTION	DATE		CM4545Z131R-10-D-3	TOOL # H0449-600



X-ON Electronics

Largest Supplier of Electrical and Electronic Components

Click to view similar products for [Common Mode Chokes / Filters](#) category:

Click to view products by [Laird](#) manufacturer:

Other Similar products are found below :

[PE-64683](#) [RD5122-6-9M6](#) [RGCMF1210900H3T](#) [ST6118T-R](#) [FE3X025-10-7NL](#) [T8114NLT](#) [TCM0806G-350-2P-T](#) [TCM0806G-650-2P-T](#)
[IND-0110](#) [UAL21VR0802000](#) [UALSC023000000](#) [UALSC1020JH000](#) [UALSU10VR15019](#) [UALSU9VD070100](#) [36-00037](#) [5701610000](#)
[UALW21HS072450](#) [UALSU9HF050500](#) [UALSU9H0208000](#) [UAL24VK06450CH](#) [PLT10HH501100PNB](#) [PLT10HH401100PNB](#)
[PLT10HH1026R0PNB](#) [PE-67531](#) [TLH10UB](#) [113 OR5](#) [2752045447](#) [CM8663Z161B-10](#) [7351V](#) [CMF16-153131](#) [T8116NLT](#) [CMS2-10-R](#)
[FE2X10-4-2NL](#) [T8003NLT](#) [CTX66-19521-R](#) [RC212-0.5-10M](#) [RC112-0.4-15M](#) [RC212-0.6-6M8](#) [RC212-0.4-15M](#) [RC112-0.3-30M](#) [4534-3](#)
[WTCTF2012Z0M751PB](#) [PH9408.814NLT](#) [B82498B3221J000](#) [PAC6006.364NLT](#) [PAC6006.444NLT](#) [PAC6006.204NLT](#) [PH9407.204NLT](#)
[PAC6006.264NLT](#) [PH9408.105NLT](#) [PH9408.494NLT](#)