

# Datasheet

WB50NBT

*Version 1.15*

---

## REVISION HISTORY

Version	Date	Notes	Approver
1.0	07 April 2015	Initial Release	Chris Cole
1.1	07 April 2015	Added Current Consumption data	Chris Cole
1.2	02 May 2015	Fixed BT chip data in specs table	Jay White
1.3	08 July 2016	Updated mechanical drawing with pin indicators (pin 1 and pin 120) Changed from HIG to Datasheet	Chris Cole
1.4	01 Sept 2016	Adding Declaration of Conformity Added numbered headings	Sue White
1.5	03 Nov 2016	Updated Tx power numbers to the following: <b>802.11a (UNII-1, UNII-2A, UNII-2C) or CH 36 – CH140</b> 6 Mbps 17 dBm (50.1 mW) 54 Mbps 14 dBm (25.1 mW) <b>802.11a (UNII-3) or CH 148 – CH 165</b> 6 Mbps 15 dBm (31.6 mW) 54 Mbps 14 dBm (25.1 mW) <b>802.11n (5 GHz) (UNII-1, UNII-2A, UNII-2C) or CH 36 – CH140</b> 6.5 Mbps (MCS0; HT20) 17 dBm (50.1 mW) 65 Mbps (MCS7;HT20) 13 dBm (20 mW) (MCS0; HT40) 14 dBm (25.1 mW) (MCS7; HT40) 11 dBm (12.5 mW) <b>802.11n (5 GHz) (UNII-3) or CH 148 – CH 165</b> 6.5 Mbps (MCS0; HT20) 15 dBm (31.6 mW) 65 Mbps (MCS7;HT20) 12 dBm (15.8 mW) (MCS0; HT40) 14 dBm (25.1 mW) (MCS7; HT40) 11 dBm (12.5 mW)	Andrew Chen
1.6	09 Dec 2016	Removed <i>Preliminary</i> references	Jay White
1.7	27 Feb 2017	Changed pin 28 (PWDN) from an Input to and Output	Mark Calhoun
1.8	10 Mar 2017	Updated 5 GHz frequency bands and operating channels info.	Kris Sidle
1.9	19 Apr 2017	Fixed FCC frequency range.	Miles Chung
1.10	24 May 2017	Updated EU DoC for new RED standards	Maggie Teng
1.11	15 June 2017	Updated EU DoC for latest RED standard (including EN 301 893 v2.1.1)	Maggie Teng
1.12		Removed <i>SPI slave</i> references	Chris Cole
1.13	18 Aug 2017	Removed 802.11r references	Jay White
1.14	01 May 2018	Updated product photo Updated Industry Canada statement Updated to new Laird template	Maggie Teng
1.15	06 Mar 2019	Updated logos and URLs	Sue White

## CONTENTS

1	Scope.....	4
2	Operational Description.....	4
3	Block Diagram .....	5
4	Specifications .....	5
4.1	Absolute Maximum Ratings .....	11
4.2	Recommended Operating Conditions and DC Power Electrical Characteristics .....	11
4.3	Power on Sequence.....	12
4.3.1	DC Electrical Characteristics (3.3 V signal level) .....	12
5	Pin Definitions.....	13
6	Mechanical Specification .....	18
7	Regulatory.....	18
7.1	Certified Antennas.....	18
8	FCC and IC Regulatory.....	18
8.1	FCC.....	19
8.1.1	Federal Communication Commission Interference Statement .....	19
8.1.2	End Product Labeling.....	20
8.1.3	Manual Information to the End User.....	20
8.2	Industry Canada .....	20
8.2.1	Industry Canada Statement.....	20
8.2.2	Antenna Information .....	20
8.2.3	Radiation Exposure Statement.....	<b>Error! Bookmark not defined.</b>
8.2.4	Déclaration d'exposition aux radiations .....	<b>Error! Bookmark not defined.</b>
8.2.5	End Product Labeling.....	<b>Error! Bookmark not defined.</b>
8.2.6	Plaque signalétique du produit final.....	<b>Error! Bookmark not defined.</b>
8.2.7	Manual Information to the End User.....	<b>Error! Bookmark not defined.</b>
8.2.8	Manuel d'information à l'utilisateur final.....	<b>Error! Bookmark not defined.</b>
9	European Union Regulatory.....	21
9.1	EU Declarations of Conformity.....	23
10	Ordering Information.....	24
10.1	General Comments.....	24

## 1 SCOPE

This document describes key hardware aspects of the Laird WB50NBT wireless bridge module. This document is intended to assist device manufacturers and related parties with the integration of this module into their host devices. Data in this document are drawn from a number of sources including data sheets for the Laird SSD50NBT, QUALCOMM Atheros AR6004, CSR CSR8811, and Atmel ATSAMA5D31A.

The information in this document is subject to change. Please refer to the [WB50NBT product page](#) on the Laird Connectivity website for the most recent version.

## 2 OPERATIONAL DESCRIPTION

This device is a Laird WB50NBT wireless bridge module, a wireless communications subsystem that may be integrated into a variety of host devices via a number of available electronic and logical interfaces. The Laird WB50NBT provides complete enterprise-class Wi-Fi connectivity with an integrated TCP/IP stack, full support for IEEE 802.11a/b/g/n, and Bluetooth 4.0 dual-mode air standards with a fully integrated security supplicant providing 802.11i/WPA2 Enterprise authentication, data encryption, and BT protocol stacks.

The WB50NBT has a wide variety of interfaces including Fast Ethernet, serial UART, Hi-Speed USB, SPI, PCM, and I2C. The wireless bridge may be configured, monitored, and managed via a Command Line Interface (CLI) over an available dedicated console port, via a web interface over a wireless or Ethernet interface, or via a remote SDK interface over wireless or Ethernet.

The WB50NBT incorporates the Laird SSD50NBT Wi-Fi SiP module which uses Qualcomm Atheros AR6004 and CSR 8811. The SSD50NBT supports 2X2 MIMO IEEE 802.11a/b/g/n and the Bluetooth standard 4.0 which includes the Bluetooth Low Energy (BLE) and legacy modes. Three-wired Wi-Fi and BT coexistence schemes are implemented inside the SSD50NBT which provides optimized performance between Wi-Fi and Bluetooth. The WB50NBT product features a Cortex A5 processor running at 536 MHz, 64 MB of Lower Power DDR (LPDDR) memory, and 128 MB of SLC NAND flash storage. Several GPIO lines are available for data acquisition and similar applications. The platform runs an embedded Linux operating system based on the 4.1 kernel. A software developer's kit (SDK) with Application Programming Interfaces (API) and software tools are available for the development of custom software applications on the device.

The WB50NBT measures 47 mm long by 37 mm wide by 4.9 mm thick. The wireless bridge physically interfaces to the host device via an 120-pin board to board (B2B) Kyocera connector (AVX)(P/N:245046120600829+), which mates to a 4.0 mm stacking height mating part from Kyocera (AVX) (P/N:145046120640829+). With different Kyocera (AVX) mating parts, different stacking heights (3.0 mm, 3.5 mm, 4.0 mm, and 4.5 mm) can be achieved. Detailed information is available in the mounting section of the Specifications table. The WB50NBT may be secured to the host device via four grounded mounting holes. The WB50NBT operates at temperatures between -30° and +85° degrees Celsius.

Contingent on compliance results, the WB50NBT is a fully integrated module. It has its own RF shielding and does not require shielding provided by the host device into which it is installed in order to maintain compliance with applicable regulatory standards. As such, the device may be tested in a standalone configuration via a breakout board (BB50NBT). The [BB50NBT schematic](#) is available as a design reference.

The WB50NBT provides the following two U.FL type antenna connectors that provide two streams MIMO operation to reach the maximum data rate:

- Main/ANT0 antenna – Wi-Fi only
- Auxiliary/ANT1 – Wi-Fi and Bluetooth

Bluetooth signals can only be presented at the auxiliary/ANT1. Supported host device antenna types include dipole and monopole antennas.



Regulatory operational requirements are included in this document and may be incorporated into the operating manual of any device into which the WB50NBT is installed. The WB50NBT is designed for installation into mobile devices which typically operate at distances greater than 20 cm from the human body and portable devices which typically operate at distances less than 20 cm from the human body. See [Documentation Requirements](#) for more information.

### 3 Block Diagram

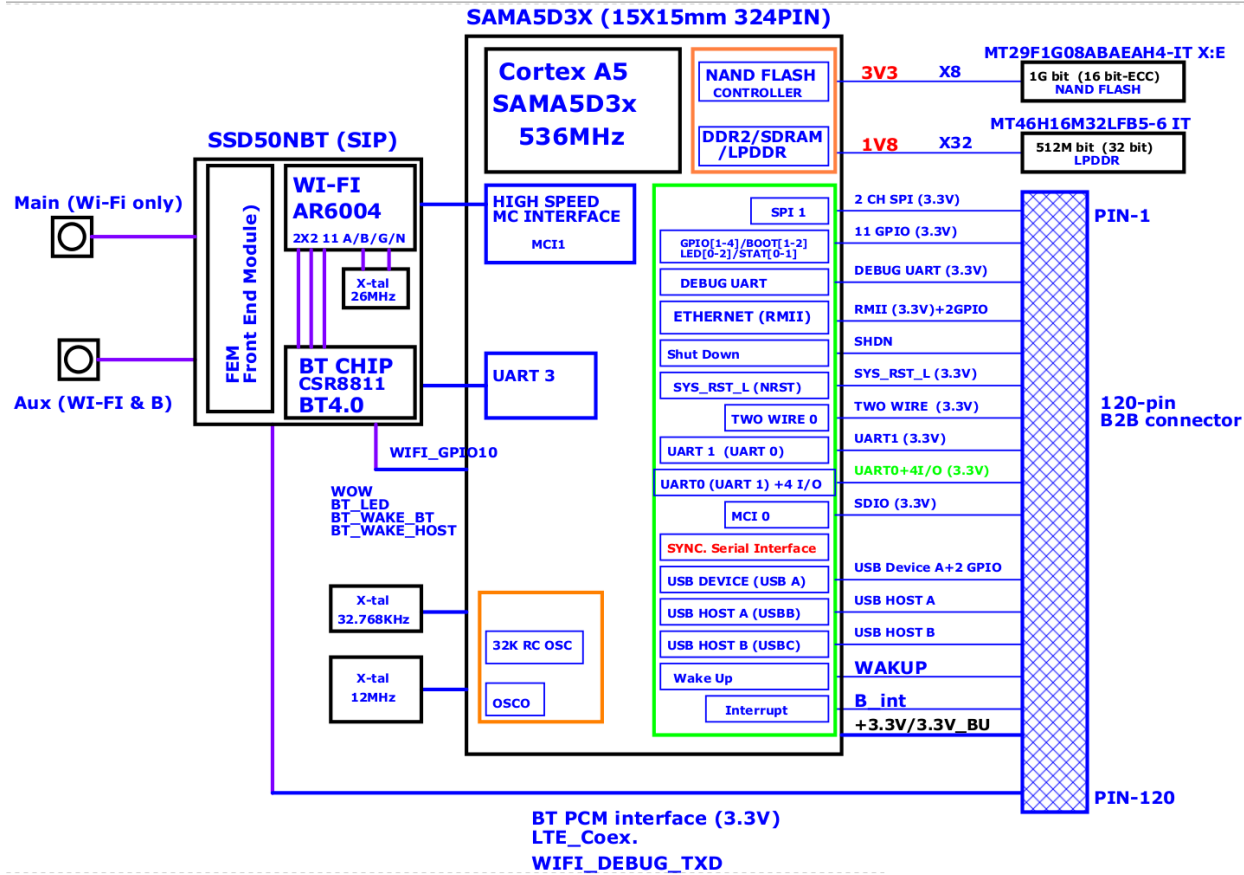

Figure 1: WB50NBT block diagram

**Note:** Transmitter frequencies for Wi-Fi are 2412-2462 MHz and 5180-5805 MHz. Transmitter frequencies for Bluetooth are 2402-2480 MHz.

**Note:** Bluetooth functions on the AUX port; Wi-Fi operates at both the Main and AUX ports.

### 4 SPECIFICATIONS

Feature	Description
Physical Interface	Pitch: 0.5 mm Kyocera (AVX) – P/N: 245046120600829+ Mating part: Kyocera (AVX) – P/N:145046120640829+ Stacking height = 4.0 mm

Feature	Description
	<b>Note:</b> See <a href="#">mounting</a> for mating connector options.
<b>Ethernet Interface (3.3 V signal level)</b>	10/100 Mbps RMII (Reduced Media Independent Interface)
<b>Asynchronous Serial Port Interfaces (3.3 V signal level)</b>	Four-wire UART with hardware handshaking (up to 921,600 baud) Full mode UART with synchronous clock to support USART interface
<b>SPI Interface (3.3 V signal level)</b>	Five Wire and Master modes supported with two-chip select
<b>USB Interfaces</b>	One USB device port with high speed/full speed/low speed data rates Two USB host ports with high speed/full speed/low speed data rates
<b>Two Wire Interface (3.3V signal level)</b>	Two-wire I2C (Inter-IC)
<b>Debug Interface</b>	Two-wire UART (console) for debug purpose
<b>Digital GPIO (3.3 V signal level)</b>	Six digital General Purpose I/O (GPIO)
<b>PCM interface</b>	13-bit or 16-bit linear, 8-bit $\mu$ -law or A-law companded sample formats
<b>Antenna Interface</b>	2 Hirose U.FL connectors for Wi-Fi (Main/AUX) and BT (AUX only) separately, 50 ohm
<b>Wi-Fi Interface</b>	Qualcomm Atheros AR6004 2x2 802.11 a/b/g/n on 20/40 MHz bandwidth
<b>Bluetooth Interface</b>	CSR CSR8811 Bluetooth 4.0 dual-mode (EDR+BLE) Class I Bluetooth (60dBm TX Power)
<b>Processor Chip Set</b>	Atmel 536 MHz ARM 9, P/N ATSAMA5D31A
<b>Operating System</b>	Embedded Linux, 4.1 kernel
<b>Memory</b>	64 MB LPDDR
<b>Storage</b>	128 MB SLC NAND flash
<b>Input Voltage Requirements</b>	VDD_BU: +3.3 VDC +/-5% (Backup) VCC3_3: +3.2V (Min) +3.46V (Max)  <b>Note:</b> Voltage ripple must be less than 30 mV.

Feature	Description			
<p><b>Current Consumption</b></p> <p><b>Note:</b> These current consumption measurements were taken using Linux kernel version 4.1.</p> <p><b>Note:</b> Standby refers to the radio operating while connected to an AP but not transmitting or receiving.</p>		<b>Mode</b>	<b>3.3 V</b>	
			<b>Average Current (mA)</b>	<b>Maximum Current (mA)</b>
	<b>802.11a</b>	Transmit	755	1385
		Receive	149	268
		Standby	65	207
	<b>802.11b</b>	Transmit	520	972
		Receive	134	234
		Standby	65	207
	<b>802.11g</b>	Transmit	495	1092
		Receive	134	234
		Standby	65	207
	<b>802.11n (2.4 GHz)</b>	Transmit	497	1092
		Receive	135	234
		Standby	65	207
	<b>802.11n (5 GHz)</b>	Transmit	731	1507
	Receive	150	268	
	Standby	65	207	
<b>Operating Temperature</b>	-30° to +85°C (-22°F to 185°F)			
<b>Operating Humidity</b>	10 to 90% (non-condensing)			
<b>Storage Temperature</b>	-30° to 85°C (-22° to 185°F)			
<b>Storage Humidity</b>	10 to 90% (non-condensing)			
<b>Maximum Electrostatic Discharge</b>	Conductive 4KV; Air coupled 8KV follow EN61000-4-2			
<b>Length/Width/Thickness</b>	47 mm x 37 mm x 4.9 mm			
	<b>Note:</b> Length, width, and thickness measurements include the metal shielding.			
<b>Weight</b>	8.6 g (0.30 oz.)			

Feature	Description								
<b>Mounting</b>	<p>Connector and through holes. Refer to <a href="#">Mechanical Specifications</a> for additional information.</p> <p><b>Recommended:</b></p> <p><b>Connector:</b></p> <ul style="list-style-type: none"> <li>Pitch: 0.5 mm, 120 pin Kyocera (AVX) P/N:245046120600829+</li> </ul> <p><b>Mating part:</b></p> <ul style="list-style-type: none"> <li>Kyocera (AVX) P/N:145046120630829+, Stacking height: 3.0 mm</li> <li>Kyocera (AVX) P/N:145046120635829+, Stacking height: 3.5 mm</li> <li>Kyocera (AVX) P/N:145046120640829+, Stacking height: 4.0 mm</li> <li>Kyocera (AVX) P/N:145046120645829+, Stacking height: 4.5 mm</li> </ul> <p><b>Stand-off for 4.0 mm stacking height:</b></p> <ul style="list-style-type: none"> <li>EMI STOP P/N:F40M20-401126D4BM</li> </ul> <p><a href="http://www.emistop.com">http://www.emistop.com</a>; <a href="mailto:sales08@emistop.com">sales08@emistop.com</a></p>								
<b>Wi-Fi Media</b>	<p>Direct Sequence-Spread Spectrum (DSSS) Complementary Code Keying (CCK) Orthogonal Frequency Divisional Multiplexing (OFDM)</p>								
<b>Wi-Fi Media Access Protocol</b>	Carrier sense multiple access with collision avoidance (CSMA/CA)								
<b>Network Architecture</b>	Infrastructure and ad hoc								
<b>Wi-Fi Standards</b>	IEEE 802.11a, 802.11b, 802.11d, 802.11e, 802.11g, 802.11h, 802.11i, 802.11n								
<b>Wi-Fi Data Rates Supported</b>	<p>802.11a (OFDM): 6, 9, 12, 18, 24, 36, 48, 54 Mbps</p> <p>802.11b (DSSS, CCK): 1, 2, 5.5, 11 Mbps</p> <p>802.11g (OFDM): 6, 9, 12, 18, 24, 36, 48, 54 Mbps</p> <p>802.11n (OFDM, HT20, MCS 0-15):</p> <p>Full Guard Interval: 6.5, 13, 19.5, 26, 39, 52, 58.5, 65, 78, 104, 117 Mbps</p> <p>Short Guard Interval: 1.2, 14.4, 21.7, 28.9, 29.9, 43.3, 57.8, 65, 72.2, 86.7, 115.6, 130, 144.4 Mbps</p>								
<b>Modulation</b>	<p>BPSK @ 1, 6.9, 6.5, 7.2, 13 and 14.4 Mbps</p> <p>QPSK @ 2, 12, 18, 13, 14.4, 19.5, 21.7, 26, 28.9, 39, 43.3 Mbps</p> <p>CCK @ 5.5 and 11 Mbps</p> <p>16-QAM @ 24, 36, 26, 29.9, 39, 43.3, 52, 57.8, 78, 86.7 Mbps</p> <p>64-QAM @ 48, 54, 52, 57.8, 58.5, 65, 72.2, 104.0, 115.6, 117.0, 130.0, 144.4 Mbps</p>								
<b>802.11n Spatial Streams</b>	2X2 MIMO (Multiple Input, Multiple Output)								
<b>Regulatory Domain Support</b>	<p>FCC (Americas, Parts of Asia, and Middle East)</p> <p>ETSI (Europe, Middle East, Africa, and Parts of Asia)</p> <p>MIC (Japan) (formerly TELEC)</p> <p>KC (Korea) (formerly KCC)</p>								
<b>2.4 GHz Frequency Bands</b>	<table border="0"> <tr> <td><b>ETSI:</b></td> <td>2.4 GHz to 2.483 GHz</td> <td><b>MIC:</b></td> <td>2.4 GHz to 2.495 GHz</td> </tr> <tr> <td><b>FCC:</b></td> <td>2.4 GHz to 2.483 GHz</td> <td><b>KC:</b></td> <td>2.4 GHz to 2.483 GHz</td> </tr> </table>	<b>ETSI:</b>	2.4 GHz to 2.483 GHz	<b>MIC:</b>	2.4 GHz to 2.495 GHz	<b>FCC:</b>	2.4 GHz to 2.483 GHz	<b>KC:</b>	2.4 GHz to 2.483 GHz
<b>ETSI:</b>	2.4 GHz to 2.483 GHz	<b>MIC:</b>	2.4 GHz to 2.495 GHz						
<b>FCC:</b>	2.4 GHz to 2.483 GHz	<b>KC:</b>	2.4 GHz to 2.483 GHz						
<b>2.4 GHz Operating Channels</b>	<table border="0"> <tr> <td><b>ETSI:</b></td> <td>13 (3 non-overlapping)</td> <td><b>MIC:</b></td> <td>14 (4 non-overlapping)</td> </tr> <tr> <td><b>FCC:</b></td> <td>11 (3 non-overlapping)</td> <td><b>KC:</b></td> <td>13 (3 non-overlapping)</td> </tr> </table>	<b>ETSI:</b>	13 (3 non-overlapping)	<b>MIC:</b>	14 (4 non-overlapping)	<b>FCC:</b>	11 (3 non-overlapping)	<b>KC:</b>	13 (3 non-overlapping)
<b>ETSI:</b>	13 (3 non-overlapping)	<b>MIC:</b>	14 (4 non-overlapping)						
<b>FCC:</b>	11 (3 non-overlapping)	<b>KC:</b>	13 (3 non-overlapping)						
<b>5 GHz Frequency Bands</b>	<p>ETSI</p> <p>5.15 GHz to 5.35 GHz (Ch 36/40/44/48/52/56/60/64)</p>								



Feature	Description
	5.47 GHz to 5.725 GHz (Ch 100/104/108/112/116/120/124/128/132/136/140) <b>FCC</b> 5.15 GHz to 5.35 GHz (Ch 36/40/44/48/52/56/60/64) 5.47 GHz to 5.725 GHz (Ch 100/104/108/112/116/120/124/128/ 132/136/140) 5.725 GHz to 5.85 GHz (Ch 149/153/157/161/165) <b>MIC (Japan)</b> 5.15 GHz to 5.35 GHz (Ch 36/40/44/48/52/56/60/64) 5.47 GHz to 5.725 GHz (Ch 100/104/108/112/116/120/124/128/ 132/136/140) <b>KC</b> 5.15 GHz to 5.35 GHz (Ch 36/40/44/48/52/56/60/64) 5.47 GHz to 5.725 GHz (Ch 100/104/108/112/116/120/124) 5.725 GHz to 5.825 GHz (Ch 149/153/157/161)
<b>5 GHz Operating Channels</b>	ETSI: 19 non-overlapping)      MIC: 19 non-overlapping FCC: 24 non-overlapping      KC: 19 non-overlapping
<b>Maximum Transmit Power</b>	<b>802.11a (UNII-1, UNII-2A, UNII-2C) or CH 36 – CH140</b> 6 Mbps      17 dBm (50.1 mW) 54 Mbps      14 dBm (25.1 mW) <b>802.11a (UNII-3) or CH 148 – CH 165</b> 6 Mbps      15 dBm (31.6 mW) 54 Mbps      14 dBm (25.1 mW) <b>802.11b</b> 1 Mbps      17 dBm (50.1 mW) 11 Mbps      17 dBm (50.1 mW) <b>802.11g</b> 6 Mbps      17 dBm (50.1 mW) 54 Mbps      14 dBm (25.1 mW) <b>802.11n (2.4 GHz)</b> 6.5 Mbps (MCS0)      17 dBm (50.1 mW) 65 Mbps (MCS7)      13 dBm (20 mW) <b>802.11n (5 GHz) (UNII-1, UNII-2A, UNII-2C) or CH 36 – CH140</b> 6.5 Mbps (MCS0; HT20)      17 dBm (50.1 mW) 65 Mbps (MCS7; HT20)      13 dBm (20 mW) (MCS0; HT40)      14 dBm (25.1 mW) (MCS7; HT40)      11 dBm (12.5 mW) <b>802.11n (5 GHz) (UNII-3) or CH 148 – CH 165</b> 6.5 Mbps (MCS0; HT20)      15 dBm (31.6 mW) 65 Mbps (MCS7; HT20)      12 dBm (15.8 mW) (MCS0; HT40)      14 dBm (25.1 mW) (MCS7; HT40)      11 dBm (12.5 mW) <b>Bluetooth</b> 1 Mbps      6 dBm (3.98 mW) 2 Mbps      6 dBm (3.98 mW) 3 Mbps      3 dBm (1.99 mW)

Note: Transmit power on each channels varies according to individual country regulations. All values for lowest data rate is nominal, +/-2 dBm.  
Others are +/-2.5dBm

Note: HT40 – 40 Mhz-wide channels  
HT20 – 20 MHz-wide channel

Feature	Description
<b>Typical Receiver Sensitivity</b>	<p><b>802.11a:</b></p> <p>6 Mbps -92 dBm</p> <p>54 Mbps -74 dBm (PER &lt;= 10%)</p> <p><b>802.11b:</b></p> <p>1 Mbps -94 dBm</p> <p>11 Mbps -87 dBm (PER &lt;= 8%)</p> <p><b>802.11g:</b></p> <p>6 Mbps -91 dBm</p> <p>54 Mbps -74 dBm (PER &lt;= 10%)</p> <p><b>802.11n (2.4 GHz)</b></p> <p>MCS0 Mbps -91 dBm</p> <p>MCS7 Mbps -71 dBm</p> <p><b>802.11n (5 GHz HT20)</b></p> <p>MCS0 Mbps -92 dBm</p> <p>MCS7 Mbps -71 dBm</p> <p><b>Bluetooth:</b></p> <p>1 Mbps -83 dBm (1DH1)</p> <p>2 Mbps -75 dBm (3DH5)</p> <p>3 Mbps -86 dBm</p>
<b>Security</b>	<p><b>Standards</b></p> <ul style="list-style-type: none"> <li>▪ Wireless Equivalent Privacy (WEP)</li> <li>▪ Wi-Fi Protected Access (WPA)</li> <li>▪ IEEE 802.11i (WPA2)</li> </ul> <p><b>Encryption</b></p> <ul style="list-style-type: none"> <li>▪ Wireless Equivalent Privacy (WEP, RC4 Algorithm)</li> <li>▪ Temporal Key Integrity Protocol (TKIP, RC4 Algorithm)</li> <li>▪ Advanced Encryption Standard (AES, Rijndael Algorithm)</li> </ul> <p><b>Encryption Key Provisioning</b></p> <ul style="list-style-type: none"> <li>▪ Static (40-bit and 128-bit lengths)</li> <li>▪ Pre-Shared (PSK)</li> <li>▪ Dynamic</li> </ul> <p><b>802.1X Extensible Authentication Protocol Types</b></p> <ul style="list-style-type: none"> <li>▪ EAP-FAST</li> <li>▪ EAP-TLS</li> <li>▪ EAP-TTLS</li> <li>▪ PEAP-GTC</li> <li>▪ PEAP-MSCHAPv2</li> <li>▪ PEAP-TLS</li> <li>▪ LEAP</li> </ul>

Feature	Description
<b>Compliance</b>	<p><b>ETSI Regulatory Domain</b></p> <p>EN 300 328 (Wi-Fi)</p> <p>EN 300 328 v1.8.1 (BT 2.1)</p> <p>EN 301 489-1</p> <p>EN 301 489-17</p> <p>EN 301 893</p> <p>EN 60950-1</p> <p>EU 2002/95/EC (RoHS)</p> <p><b>FCC Regulatory Domain</b></p> <p>FCC 15.247 DTS – 802.11b/g (Wi-Fi) – 2.4 GHz</p> <p>FCC 15.407 UNII – 802.11a (Wi-Fi) – 5 GHz</p> <p>FCC 15.247 DSS – BT 2.1</p> <p><b>Industry Canada</b></p> <p>RSS-247 – 802.11a/b/g/n (Wi-Fi) – 2.4 GHz, 5.8 GHz, 5.2 GHz, and 5.4 GHz</p> <p>RSS-247 – BT 2.1</p>
<b>Certifications</b>	<p><b>Wi-Fi Alliance</b></p> <p>802.11a, 802.11b, 802.11g , 802.11n</p> <p>WPA Enterprise</p> <p>WPA2 Enterprise</p> <p>Cisco Compatible Extensions (Version 4)</p> 
<b>Note:</b> Pursuing MIC and KC certifications is currently TBD.	
<b>Note:</b> These certifications are pending.	
<b>Warranty</b>	Three Year Warranty

All specifications are subject to change without notice

## 4.1 Absolute Maximum Ratings

Parameter	Comments	Conditions	Min.	Typ.	Max.	Unit
<b>Input Voltage</b>	3.3V VCC pin	With respect to ground	-0.3	-	3.8	V
	I/O pin		-0.3	-	3.8	V
<b>RF input</b>		Maximum RF input from the antenna port (reference to 50 ohm)			+10	dBm

**Note:** Voltage operated over the maximum limit may cause permanent damage to the device. These are stress ratings only; functional operation of the device at these or any other conditions beyond those indicated under [Recommended Operating Conditions](#) is not implied. Exposure to absolute-maximum-rated conditions for extended periods may affect device reliability.

## 4.2 Recommended Operating Conditions and DC Power Electrical Characteristics

Parameter	Comments	Conditions	Min.	Typ.	Max.	Unit
-----------	----------	------------	------	------	------	------

Parameter	Comments	Conditions	Min.	Typ.	Max.	Unit
Supply Voltage	VCC3_3/VDD BU	Referred to GND	3.2	3.3	3.46	V
Voltage Ripple	VCC3_3/VDD BU	Referred to GND	-	-	30	mV
Recommend Voltage	VCC3_3		-	-	2000	mA
Supply Current Rating	VDD_BU		-	-	10	
DC Output Current	I/O pin	3.3 V signal level	-	-	8	mA
Voltage Rise Time	At power on	3.3 V / 3.3 VBU	-	-	0.5	ms
Operating Current	WLAN sub-system	Continuous receive	-	TBD	-	mA
		Continuous transmit	-	TBD	-	
	Bluetooth sub-system	Continuous receive	-	TBD	-	mA
		Continuous transmit	-	TBD	-	
CPU sub-system	Varies with system load	-	TBD	-	mA	
Operating Temperature			-30	-	+85	°C

## 4.3 Power on Sequence

**Notes:** Apply the 3.3 V (backup and system) at the same time.

The CPU implements the internal POR (Power-On-Reset) and guarantees that the power sources reach their target values prior to the release of POR.

### 4.3.1 DC Electrical Characteristics (3.3 V signal level)

- I/O** Indicates whether the signal is input or output state.
- PU/PD** Indicates whether Pull-Up, Pull-Down, or nothing is enabled.
- ST** Indicates if Schmitt Trigger is enabled.
- TR** Tri-state

GPIO [1-6]	PIO, I, PU, ST
LED [0-2]	PIO, I, PU, ST
STAT_0; STAT_1	PIO, I, PU, ST
SHDN	O
NRST	I, PU, ST
BINT	I, PU, ST
WKUP	I,PU, ST
DDM; DDP; HDMA; HDP; HDMA; HDPA; HDMB; HDPB	O, PD
E_TXEN; E_TX [0-1]; E_RXER; E_RX [0-1]; E_MDC;	PIO, I, PU, ST
E_MDIO; E_CRSDV; E_REFCK; E_RST_L; E_INT	TBD
BT_PCM_OUT; BT_PCM_IN; BT_PCM_SYNC; BT_PCM_CLK	TBD
XPABIAS50; XPABIAS51; XPABIAS20; XPABIAS21	TBD
AR6004_GPIO38	TBD

LTE_ACTIVE	TBD
LTE_FRAME_SYNC	TBD
WCN_PRIORITY	TBD

Parameter	Conditions	Min.	Typ.	Max.	Unit
V <sub>IL</sub>	Input Low-Level Voltage	-0.3	-	0.8	V
V <sub>IH</sub>	Input High-Level Voltage	2.0	-	3.6	V
V <sub>OL</sub>	Output Low-Level Voltage	-	-	0.4	V
V <sub>OH</sub>	Output High-Level Voltage	2.9	-	-	V
V <sub>HYS</sub>	Schmitt trigger Hysteresis	0.34	-	-	V
R <sub>PULLUP</sub>	Pull-up/Pull-down Resistance	45	100	130	KΩ
I <sub>O</sub>	Output Current	-	-	8	mA

## 5 PIN DEFINITIONS

Table 1: Pin Definitions

#	Pin Name	Section	I/O	Reference	Description	If Unused
1	GND		-	-	Ground	Must be connected to GND
2	GPIO_1	GPIO	I/O	VCC3_3	General I/O 1	Leave open
3	SPI_NPCS1		O	VCC3_3	SPI Bus Chip Select 1	Leave open
4	GPIO_2	GPIO	I/O	VCC3_3	General I/O 2	Leave open
5	SPI_NPCS0		O	VCC3_3	SPI Bus Chip Select 0	Leave open
6	GPIO_3	GPIO	I/O	VCC3_3	General I/O 3	Leave open
7	GND		-	-	Ground	Must be connected to GND
8	GPIO_4	GPIO	I/O	VCC3_3	General I/O 4	Leave open
9	SPI_MOSI		O	VCC3_3	SPI Master Out	Leave open
10	DRXD	DBGU	I	VCC3_3	Console/Debug Serial Input	Leave open
11	SPI_MISO		I	VCC3_3	SPI Master In	Leave open
12	DTXD	DBGU	O	VCC3_3	Console/Debug Serial Output	Leave open
13	GND		-	-	Ground	Must be connected to GND
14	GPIO_5	GPIO	I/O	VCC3_3	General I/O 5	Leave open
15	SPI_CLK		O	VCC3_3	SPI Programming Clock Master – O	Leave open
16	GPIO_6	GPIO	I/O	VCC3_3	General I/O 6	Leave open
17	GND		-	-	Ground	Must be connected to GND
18	LED_0		O	VCC3_3	LED Indicator (WLAN Act) (I <sub>O</sub> = 8 Ma maximum)	Leave open

#	Pin Name	Section	I/O	Reference	Description	If Unused
19	E_REFCK		I	VCC3_3	Ethernet Reference Clock (50 MHz maximum)	Leave open
20	LED_1		O	VCC3_3	LED Indicator (TBD) (IO = 8 Ma maximum)	Leave open
21	GND		-	-	Ground	Must be connected to GND
22	LED_2		O	VCC3_3	LED Indicator (TBD) (IO = 8 Ma maximum)	Leave open
23	E_TXD0		O	VCC3_3	Ethernet Data Output 0	Leave open
24	STAT_0		O	VCC3_3	Status High while system in reset, bootloader, or OS boot; Low when OS is up	Leave open
25	E_TXD1		O	VCC3_3	Ethernet Data Output 1	Leave open
26	STAT_1		O	VCC3_3	Status High when system is running; Low when system is in suspend state	Leave open
27	GND		-	-	Ground	Must be connected to GND
28	PWDN (SHDN)		O	VDD_BU	Power down the Module Active low	100K Pull High
29	E_RXD0		I	VCC3_3	Ethernet Data Input 0	Leave open
30	NRST (RESET)		I	VCC3_3	HW System Reset Active low	100K Pull High
31	E_RXD1		I	VCC3_3	Ethernet Data Input 1	Leave open
32	GND		-	-	Ground	Must be connected to GND
33	GND		-	-	Ground	Must be connected to GND
34	TW_D		I/O	VCC3_3	Two-wire Serial Data	Leave open
35	E_TXEN		O	VCC3_3	Ethernet Transmit Enable	Leave open
36	TW_CLK		I/O	VCC3_3	Two-wire Serial Clock	Leave open
37	E_CRSDV		I	VCC3_3	Ethernet Carrier Sense and Valid Data	Leave open
38	GND		-	-	Ground	Must be connected to GND
39	E_RXER		I	VCC3_3	Ethernet Receive Error	Leave open
40	TXD_1		O	VCC3_3	Serial UART1 Transmit Data 1	Leave open
41	E_RST_L		O	VCC3_3	Ethernet Reset	Leave open
42	RXD_1		I	VCC3_3	Serial UART1 Receive Data 1	Leave open
43	E_MDC		O	VCC3_3	Ethernet Management Data Clock	Leave open
44	CTS_1		I	VCC3_3	UART1 Interface, clear-to-send, active low	Leave open
45	E_MDIO		I/O	VCC3_3	Ethernet Management Data I/O	Leave open

#	Pin Name	Section	I/O	Reference	Description	If Unused
46	RTS_1		O	VCC3_3	UART1 Interface, request-to-send, active low	Leave open
47	E_INT		I	VCC3_3	Ethernet Interrupt Request	Leave open
48	GND		-	-	Ground	Must be connected to GND
49	GND		-	-	Ground	Must be connected to GND
50	CTS_0		I	VCC3_3	UART0 Interface, clear-to-send, active low	Leave open
51	MC_DA3		I/O	VCC3_3	SDIO Multimedia Card Data 3	Leave open
52	RTS_0		O	VCC3_3	UART0 Interface, request-to-send, active low	Leave open
53	MC_DA2		I/O	VCC3_3	SDIO Multimedia Card Data 2	Leave open
54	DSR_0		I	VCC3_3	UART0 Interface, Data Set Ready	10K Pull High
55	GND		-	-	Ground	Must be connected to GND
56	DTR_0		O	VCC3_3	UART0 Interface, Data Terminal Ready	Leave open
57	MC_DA1		I/O	VCC3_3	SDIO Multimedia Card Data 1	Leave open
58	RI_0		I	VCC3_3	UART0 Ring Indicator 1	10K Pull High
59	MC_DA0		I/O	VCC3_3	SDIO Multimedia Card Data 0	Leave open
60	DCD_0		I	VCC3_3	UART0 Data Carrier Detect	10K Pull High
61	GND		-	-	Ground	Must be connected to GND
62	GND		-	-	Ground	Must be connected to GND
63	MC_CLK		O	VCC3_3	SDIO Multimedia Card Clock	Leave open
64	S_CLK_0		I/O	VCC3_3	UART0 Serial Clock	Leave open
65	GND		-	-	Ground	Must be connected to GND
66	TXD_0		O	VCC3_3	UART0 Serial Output	Leave open
67	MC_CDA		I/O	VCC3_3	SDIO Multimedia Card Command	Leave open
68	RXD_0		I	VCC3_3	UART0 Serial Input	Leave open
69	GND		-	-	Ground	Must be connected to GND
70	GND		-	-	Ground	Must be connected to GND
71	N/C		-	-	No Connection	Leave open
72	B_INT (IRQ)		I	VCC3_3	External Bus Interface Interrupt Request	100K Pull High
73	N/C		-	-	No Connection	Leave open
74	WKUP		I	VDD_BU	Interrupt Signal to wake up module;	100K Pull High

#	Pin Name	Section	I/O	Reference	Description	If Unused
					active low	
75	N/C		-	-	No Connection	Leave open
76	GND		-	-	Ground	Must be connected to GND
77	GND		-	-	Ground	Must be connected to GND
78	XPABIAS50		O	VCC3_3	External 5GHz booster control signal to turn on the PA for Chain 0.	Leave open
79	N/C		-	-	No Connection	Leave open
80	XPABIAS51		O	VCC3_3	External 5GHz booster control signal to turn on the PA for Chain 1	Leave open
81	N/C		-	-	No Connection	Leave open
82	GND		-	-	Ground	Must be connected to GND
83	N/C		-	-	No Connection	Leave open
84	XPABIAS20		O	VCC3_3	External 2.4GHz booster control signal to turn on the PA for Chain 0	Leave open
85	GND		-	-	Ground	Must be connected to GND
86	XPABIAS21		O	VCC3_3	External 2.4GHz booster control signal to turn on the PA for Chain 1	Leave open
87	GPIO_DPU_CNTRL		O	VCC3_3	USB device pull-up resistor enable; active high	Leave open
88	BT_PCM_SYN_C		O	VCC3_3	PCM Sync	Leave open
89	DBUSSENSE		I	VCC3_3	USB device bus sense signal from peripheral to host; active low	Leave open
90	BT_PCM_IN		I	VCC3_3	PCM Signal Input	Leave open
91	GND		-	-	Ground	Must be connected to GND
92	BT_PCM_OUT		O	VCC3_3	PCM Signal Output	Leave open
93	DDM		I/O	-	USB Device Data Negative	Leave open
94	GND		-	-	Ground	Must be connected to GND
95	DDP		I/O	-	USB Device Data Positive	Leave open
96	BT_PCM_CLK		I/O	VCC3_3	PCM Clock Signal	Leave open
97	GND		-	-	Ground	Must be connected to GND
98	AR6004_GPIO_38		I/O	VCC3_3	Reserved for feature LTE coexistence ; Reserved for WiFi LED indicator, Active High	Leave open
99	HDMA		I/O	-	USB Host A Data Negative	Leave open



#	Pin Name	Section	I/O	Reference	Description	If Unused
100	GND		-	-	Ground	Must be connected to GND
101	HDP A		I/O	-	USB Host A Data Positive	Leave open
102	LTE_COEX3		I/O	VCC3_3	Reserved for LTE coexistence	Leave open
103	GND		-	-	Ground	Must be connected to GND
104	LTE_ACTIVE		I/O	VCC3_3	Reserved for LTE coexistence	Leave open
105	HDM B		I/O	-	USB Host B Data Negative	Leave open
106	LTE_FRAME_SYNC		I/O	VCC3_3	Reserved for feature usage	Leave open
107	HDP B		I/O	-	USB Host B Data Positive	Leave open
108	WCN_PRIORITY		I/O	VCC3_3	Reserved for LTE coexistence	Leave open
109	GND		-	-	Ground	Must be connected to GND
110	GND		-	-	Ground	Must be connected to GND
111	GND		-	-	Ground	Must be connected to GND
112	DEBUG_UART_TXD		O	VCC3_3	WLAN debug UART TXD output.	Leave open
113	GND		-	-	Ground	Must be connected to GND
114	GND		-	-	Ground	Must be connected to GND
115	VDD_BU		-	-	Module Back-up Power 3.3V	
116	GND		-	-	Ground	Must be connected to GND
117	VCC3_3		-	-	3.3V Module Power	
118	VCC3_3		-	-	3.3V Module Power	
119	VCC3_3		-	-	3.3V Module Power	
120	VCC3_3		-	-	3.3V Module Power	

## 6 MECHANICAL SPECIFICATION

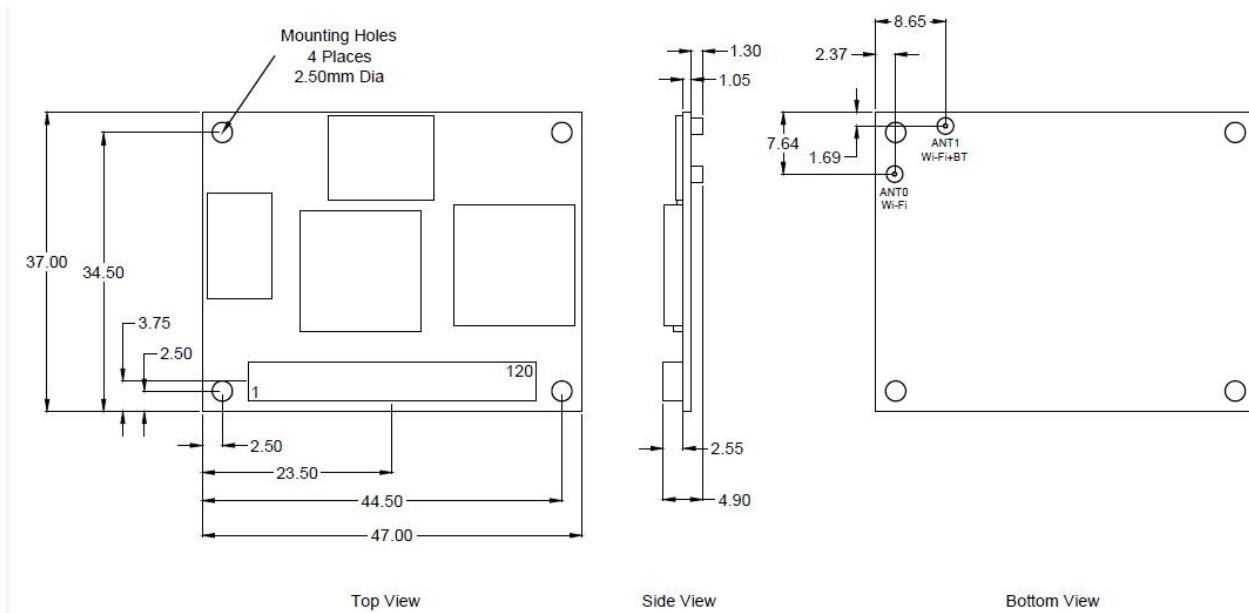

Figure 2: WB50NBT mechanical drawing

## 7 REGULATORY

### 7.1 Certified Antennas

The WB50NBT will be tested to the regulatory standards defined in the *Certifications* section of the Specifications table above. Laird plans to conduct these tests with the following antennas:

Model	Type	Connector	2400~2483.5MHz	
			5150~5250MHz	5250~5350MHz
Laird MAF94051	Dipole	RP-SMA	2.1 dBi (2.4-2.5 GHz), 2.4 dBi (4.9 GHz)	2.6 dBi (5.25 GHz), 3.4 dBi (5.875 GHz)
Laird/NanoBlade-IP04	PCB Dipole	IPEX MHF	2 dBi (2.4-2.5 GHz),	3.9 dBi (5.15-5.35 GHz), 4 dBi (5.6 GHz)
Laird/MAF95310 Mini Nano Blade Flex	PCB Dipole	IPEX MHF	2.79 dBi (2.4 GHz),	3.38 dBi (5 GHz)
Laird/NanoBlue-IP04	PCB Dipole	IPEX MHF	2 dBi (2.4 GHz only)	
Ethertronics/WLAN_1000146	Isolated Magnetic Dipole	IPEX MHF	2.5 dBi (2.390-2.490 GHz),	3.5 dBi (4.900-5.100, 5.150-5.350, 5.70-5.900 GHz)

## 8 FCC AND IC REGULATORY

Model	US/FCC	CANADA/IC
WB50NBT	SQG-WB50NBT	3147A-WB50NBT

The WB50NBT is designed to pass certification with the antenna listed below. The required antenna impedance is 50 ohms.

Model	Type	Connector	Peak gain ( dBi )				
			2400~2483.5 MHz	5150~5250M Hz	5250~5350M Hz	5470~5725 MHz	5725~5850M Hz
Laird MAF94051	Dipole	RP-SMA	2.1 dBi	2.4 dBi	2.6 dBi	3.4 dBi	
Laird NanoBlade-IP04	PCB Dipole	IPEX MHF	2 dBi	3.9 dBi		4 dBi	
Laird MAF95310 Mini NanoBlade Flex	PCB Dipole	IPEX MHF	2.79 dBi	3.38 dBi			
Laird NanoBlue-IP04	PCB Dipole	IPEX MHF	2dBi	-			
Ethertronics WLAN_1000146	Isolated Magnetic Dipole	IPEX MHF	2.5dBi	3.5 dBi			

## 8.1 FCC

### 8.1.1 Federal Communication Commission Interference Statement

This equipment has been tested and found to comply with the limits for a Class B digital device, pursuant to Part 15 of the FCC Rules. These limits are designed to provide reasonable protection against harmful interference in a residential installation. This equipment generates, uses and can radiate radio frequency energy and, if not installed and used in accordance with the instructions, may cause harmful interference to radio communications. However, there is no guarantee that interference will not occur in a particular installation. If this equipment does cause harmful interference to radio or television reception, which can be determined by turning the equipment off and on, the user is encouraged to try to correct the interference by one of the following measures:

- Reorient or relocate the receiving antenna.
- Increase the separation between the equipment and receiver.
- Connect the equipment into an outlet on a circuit different from that to which the receiver is connected.
- Consult the dealer or an experienced radio/TV technician for help.

#### *FCC Caution:*

Any changes or modifications not expressly approved by the party responsible for compliance could void the user's authority to operate this equipment.

This device complies with Part 15 of the FCC Rules. Operation is subject to the following two conditions: (1) This device may not cause harmful interference, and (2) this device must accept any interference received, including interference that may cause undesired operation.

#### *Important Note:*

#### **Radiation Exposure Statement**

This equipment complies with FCC radiation exposure limits set forth for an uncontrolled environment. This equipment should be installed and operated with minimum distance 20cm between the radiator and your body.

This transmitter must not be co-located or operating in conjunction with any other antenna or transmitter.

Country Code selection feature to be disabled for products marketed to the US/Canada.

**This device is intended only for OEM integrators under the following conditions:**

1. The antenna must be installed such that 20 cm is maintained between the antenna and users, and
2. The transmitter module may not be co-located with any other transmitter or antenna,
3. For all products market in US, OEM has to limit the operation channels in CH1 to CH11 for 2.4G band by supplied firmware programming tool. OEM shall not supply any tool or info to the end-user regarding to Regulatory Domain change.

As long as the three conditions above are met, further **transmitter** testing will not be required. However, the OEM integrator is still responsible for testing their end-product for any additional compliance requirements required with this module installed.

**Important Note:**

In the event that these conditions **cannot be met** (for example certain laptop configurations or co-location with another transmitter), then the FCC authorization is no longer considered valid and the FCC ID **cannot** be used on the final product. In these circumstances, the OEM integrator will be responsible for re-evaluating the end product (including the transmitter) and obtaining a separate FCC authorization.

### 8.1.2 End Product Labeling

This transmitter module is authorized only for use in device where the antenna may be installed such that 20 cm may be maintained between the antenna and users. The final end product must be labeled in a visible area with the following for the WB50NBT: **Contains FCC ID: SQG-WB50NBT.**

### 8.1.3 Manual Information to the End User

The OEM integrator has to be aware not to provide information to the end user regarding how to install or remove this RF module in the user’s manual of the end product which integrates this module.

The end user manual shall include all required regulatory information/warning as show in this manual.

## 8.2 Industry Canada

### 8.2.1 Industry Canada Statement

This device complies with Industry Canada’s licence-exempt RSSs. Operation is subject to the following two conditions:

- (1) This device may not cause interference; and
- (2) This device must accept any interference, including interference that may cause undesired operation of the device.

Le présent appareil est conforme aux CNR d’Industrie Canada applicables aux appareils radio exempts de licence. L’exploitation est autorisée aux deux conditions suivantes:

- 1) l’appareil ne doit pas produire de brouillage;
- 2) l’utilisateur de l’appareil doit accepter tout brouillage radioélectrique subi, même si le brouillage est susceptible d’en compromettre le fonctionnement.

This radio transmitter (IC: 3147A-WB50NBT) has been approved by Industry Canada to operate with the antenna types listed below with the maximum permissible gain indicated. Antenna types not included in this list, having a gain greater than the maximum gain indicated for that type, are strictly prohibited for use with this device.

Le présent émetteur radio (IC: 3147A-WB50NBT) a été approuvé par Industrie Canada pour fonctionner avec les types d’antenne énumérés ci-dessous et ayant un gain admissible maximal. Les types d’antenne non inclus dans cette liste, et dont le gain est supérieur au gain maximal indiqué, sont strictement interdits pour l’exploitation de l’émetteur.

### 8.2.2 Antenna Information

Model	Type	Connector	Peak gain ( dBi )
-------	------	-----------	-------------------

Model	Type	Connector	Peak gain ( dBi )				
			2400~2483.5 MHz	5150~5250 MHz	5250~5350 MHz	5470~5725 MHz	5725~5850 MHz
Laird MAF94051	Dipole	RP-SMA	2.1 dBi	2.4 dBi	2.6 dBi	3.4 dBi	
Laird NanoBlade-IP04	PCB Dipole	IPEX MHF	2 dBi	3.9 dBi		4 dBi	
Laird MAF95310 Mini NanoBlade Flex	PCB Dipole	IPEX MHF	2.79 dBi	3.38 dBi			
Laird NanoBlue-IP04	PCB Dipole	IPEX MHF	2dBi	-			
Ethertronics WLAN_1000146	Isolated Magnetic Dipole	IPEX MHF	2.5dBi	3.5 dBi			

**Caution:**

- (i) the device for operation in the band 5150–5250 MHz is only for indoor use to reduce the potential for harmful interference to co-channel mobile satellite systems;
- (ii) for devices with detachable antenna(s), the maximum antenna gain permitted for devices in the bands 5250-5350 MHz and 5470-5725 MHz shall be such that the equipment still complies with the e.i.r.p. limit;
- (iii) for devices with detachable antenna(s), the maximum antenna gain permitted for devices in the band 5725-5850 MHz shall be such that the equipment still complies with the e.i.r.p. limits specified for point-to-point and non-point-to-point operation as appropriate; and

Operations in the 5.25-5.35GHz band are restricted to indoor usage only.

**Avertissement:**

- (i) les dispositifs fonctionnant dans la bande de 5150 à 5250MHz sont réservés uniquement pour une utilisation à l'intérieur afin de réduire les risques de brouillage préjudiciable aux systèmes de satellites mobiles utilisant les mêmes canaux;
- (ii) pour les dispositifs munis d'antennes amovibles, le gain maximal d'antenne permis pour les dispositifs utilisant les bandes de 5250 à 5350MHz et de 5470 à 5725 MHz doit être conforme à la limite de la p.i.r.e.;
- (iii) pour les dispositifs munis d'antennes amovibles, le gain maximal d'antenne permis (pour les dispositifs utilisant la bande de 5725 à 5850 MHz) doit être conforme à la limite de la p.i.r.e. spécifiée pour l'exploitation point à point et l'exploitation non point à point, selon le cas;

Les opérations dans la bande de 5.25-5.35GHz sont limités à un usage intérieur seulement.

**Radiation Exposure Statement:**

This equipment complies with Canada radiation exposure limits set forth for an uncontrolled environment. This equipment should be installed and operated with minimum distance 20cm between the radiator & your body.

**Déclaration d'exposition aux radiations:**

Cet équipement est conforme Canada limites d'exposition aux radiations dans un environnement non contrôlé. Cet équipement doit être installé et utilisé à distance minimum de 20cm entre le radiateur et votre corps.

This device is intended only for OEM integrators under the following conditions:

- 1) The transmitter module may not be co-located with any other transmitter or antenna.

As long as 1 condition above are met, further transmitter test will not be required. However, the OEM integrator is still responsible for testing their end-product for any additional compliance requirements required with this module installed.

Cet appareil est conçu uniquement pour les intégrateurs OEM dans les conditions suivantes:

1) Le module émetteur peut ne pas être coïmplanté avec un autre émetteur ou antenne.

Tant que les 1 condition ci-dessus sont remplies, des essais supplémentaires sur l'émetteur ne seront pas nécessaires. Toutefois, l'intégrateur OEM est toujours responsable des essais sur son produit final pour toutes exigences de conformité supplémentaires requis pour ce module installé.

**IMPORTANT NOTE:**

In the event that these conditions cannot be met (for example certain laptop configurations or co-location with another transmitter), then the Canada authorization is no longer considered valid and the IC ID cannot be used on the final product. In these circumstances, the OEM integrator will be responsible for re-evaluating the end product (including the transmitter) and obtaining a separate Canada authorization.

**NOTE IMPORTANTE:**

Dans le cas où ces conditions ne peuvent être satisfaites (par exemple pour certaines configurations d'ordinateur portable ou de certaines co-localisation avec un autre émetteur), l'autorisation du Canada n'est plus considéré comme valide et l'ID IC ne peut pas être utilisé sur le produit final. Dans ces circonstances, l'intégrateur OEM sera chargé de réévaluer le produit final (y compris l'émetteur) et l'obtention d'une autorisation distincte au Canada.

*End Product Labeling*

The final end product must be labeled in a visible area with the following: "Contains IC: 3147A-WB50NBT".

*Plaque signalétique du produit final*

Le produit final doit être étiqueté dans un endroit visible avec l'inscription suivante: "Contient des IC: 3147A-WB50NBT".

*Manual Information to the End User*

The OEM integrator has to be aware not to provide information to the end user regarding how to install or remove this RF module in the user's manual of the end product which integrates this module.

The end user manual shall include all required regulatory information/warning as show in this manual.

*Manuel d'information à l'utilisateur final*

L'intégrateur OEM doit être conscient de ne pas fournir des informations à l'utilisateur final quant à la façon d'installer ou de supprimer ce module RF dans le manuel de l'utilisateur du produit final qui intègre ce module.

Le manuel de l'utilisateur final doit inclure toutes les informations réglementaires requises et avertissements comme indiqué dans ce manuel.

## 9 EUROPEAN UNION REGULATORY

The WB50NBT has been tested for compliance with relevant standards for the EU market. The WB50NBT module was tested with antennas listed below.

Model	Type	Connector	2400~2483.5MHz	
			5150~5250MHz	5250~5350MHz
Laird MAF94051	Dipole	RP-SMA	2.1 dBi (2.4-2.5 GHz), 2.4 dBi (4.9 GHz)	
			2.6 dBi (5.25 GHz), 3.4 dBi (5.875 GHz)	

Model	Type	Connector	2400~2483.5MHz	
			5150~5250MHz	5250~5350MHz
Laird/NanoBlade-IP04	PCB Dipole	IPEX MHF	2 dBi (2.4-2.5 GHz), 3.9 dBi (5.15-5.35 GHz), 4 dBi (5.6 GHz)	
Laird/MAF95310 Mini Nano Blade Flex	PCB Dipole	IPEX MHF	2.79 dBi (2.4 GHz), 3.38 dBi (5 GHz)	
Laird/NanoBlue-IP04	PCB Dipole	IPEX MHF	2 dBi (2.4 GHz only)	
Ethertronics/WLAN_1000146	Isolated Magnetic Dipole	IPEX MHF	2.5 dBi (2.390-2.490 GHz), 3.5 dBi (4.900-5.100, 5.150-5.350, 5.70-5.900 GHz)	

The OEM should consult with a qualified test house before entering their device into an EU member country to make sure all regulatory requirements have been met for their complete device.

Reference the Declaration of Conformities listed below for a full list of the standards that the modules were tested to. Test reports are available upon request.

## 9.1 EU Declarations of Conformity

### WB50NBT

<b>Manufacturer</b>	Laird
<b>Products</b>	WB50NBT
<b>Product Description</b>	50 Series Dual-band 802.11n + BT4.0
<b>EU Directives</b>	2014/53/EU – Radio Equipment Directive (RED)



#### Reference standards used for presumption of conformity:

Article Number	Requirement	Reference standard(s)
3.1a	Low voltage equipment safety	EN 60950-1:2006 +A11:2009 +A1:2010 +A12:2011 +A2:2013
	RF Exposure	EN 62311:2008 EN 50385:2002
3.1b	Protection requirements – Electromagnetic compatibility	EN 301 489-1 v2.2.0 (2017-03) EN 301 489-17 v3.2.0 (2017-03) EN 55022:2010
3.2	Means of the efficient use of the radio frequency spectrum (ERM)	EN 300 328 v2.1.1 (2016-11) EN 301 893 v2.1.1 (2017-05)

#### Declaration:

We, Laird, declare under our sole responsibility that the essential radio test suites have been carried out and that the above product to which this declaration relates is in conformity with all the applicable essential requirements of Article 3 of the EU Radio Equipment Directive 2014/53/EU, when used for its intended purpose.

Place of Issue:	Laird W66N220 Commerce Court, Cedarburg, WI 53012 USA tel: +1-262-375-4400 fax: +1-262-364-2649
Date of Issue:	June 2017
Name of Authorized Person:	Thomas T Smith, Director of EMC Compliance

Signature of Authorized Person:

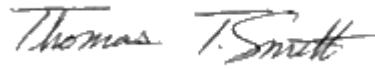

Maximum Output Power for Each Frequency

20.00 dBm, 2.4G: 2.412 GHz~2.472 GHz	22.50 dBm, 5.15-5.25GHz
9.00 dBm, for BT	22.70 dBm, 5.25-5.35GHz
9.00 dBm, for BT LE	30.00 dBm, 5.47-5.725GHz

Software Version for Testing

SW version: 3.5.2.15

The minimum distance between the user and/or any bystander and the radiating structure of the transmitter is 20 cm.

5150 ~ 5350 MHz is limited to indoor used in the following countries:



BE	DK	IE	FR	CY	LU	NL	PT	SK	UK	NO
BG	DE	EL	HR	LV	HU	AT	RO	FI	LI	TR
CZ	EE	ES	IT	LT	MT	PL	SI	SE	IS	CH

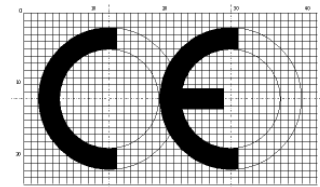









## 10 ORDERING INFORMATION

Product Name	Description	Part Number
WB50NBT	802.11a/b/g/n - BT 4.0 Communications Subsystem	WH-WB50NBT
DVK-WB50NBT	Development Breakout board WB50NBT module included	DVK-WB50NBT

### 10.1 General Comments

Please check with Laird for the latest information before commencing a design. If in doubt, ask.

 <b>Česky</b> [Czech]	<i>[Jméno výrobce]</i> tímto prohlašuje, že tento <i>[typ zařízení]</i> je ve shodě se základními požadavky a dalšími příslušnými ustanoveními směrnice 1999/5/ES.
 <b>Dansk</b> [Danish]	Undertegnede <i>[fabrikantens navn]</i> erklærer herved, at følgende udstyr <i>[udstyrets typebetegnelse]</i> overholder de væsentlige krav og øvrige relevante krav i direktiv 1999/5/EF.
 <b>Deutsch</b> [German]	Hiermit erkläre <i>[Name des Herstellers]</i> , dass sich das Gerät <i>[Gerätetyp]</i> in Übereinstimmung mit den grundlegenden Anforderungen und den übrigen einschlägigen Bestimmungen der Richtlinie 1999/5/EG befindet.
 <b>Eesti</b> [Estonian]	Käesolevaga kinnitab <i>[tootja nimi = name of manufacturer]</i> seadme <i>[seadme tüüp = type of equipment]</i> vastavust direktiivi 1999/5/EÜ põhinõuetele ja nimetatud direktiivist tulenevatele teistele asjakohastele sätetele.
 <b>English</b>	Hereby, <i>[name of manufacturer]</i> , declares that this <i>[type of equipment]</i> is in compliance with the essential requirements and other relevant provisions of Directive 1999/5/EC.
 <b>Español</b> [Spanish]	Por medio de la presente <i>[nombre del fabricante]</i> declara que el <i>[clase de equipo]</i> cumple con los requisitos esenciales y cualesquiera otras disposiciones aplicables o exigibles de la Directiva 1999/5/CE.
 <b>Ελληνική</b> [Greek]	ΜΕ ΤΗΝ ΠΑΡΟΥΣΑ <i>[name of manufacturer]</i> ΔΗΛΩΝΕΙ ΟΤΙ <i>[type of equipment]</i> ΣΥΜΜΟΡΦΩΝΕΤΑΙ ΠΡΟΣ ΤΙΣ ΟΥΣΙΩΔΕΙΣ ΑΠΑΙΤΗΣΕΙΣ ΚΑΙ ΤΙΣ ΛΟΙΠΕΣ ΣΧΕΤΙΚΕΣ ΔΙΑΤΑΞΕΙΣ ΤΗΣ ΟΔΗΓΙΑΣ 1999/5/ΕΚ.
 <b>Français</b>	Par la présente <i>[nom du fabricant]</i> déclare que l'appareil <i>[type d'appareil]</i> est conforme aux



<b>[French]</b>	exigences essentielles et aux autres dispositions pertinentes de la directive 1999/5/CE.
<b>[it] Italiano [Italian]</b>	Con la presente <i>[nome del costruttore]</i> dichiara che questo <i>[tipo di apparecchio]</i> è conforme ai requisiti essenziali ed alle altre disposizioni pertinenti stabilite dalla direttiva 1999/5/CE.
<b>Latviski [Latvian]</b>	Aršo <i>[name of manufacturer /izgatavotājanosaukums]</i> deklarē, ka <i>[type of equipment / iekārtas tips]</i> atbilst Direktīvas 1999/5/EK būtiskajām prasībām un citiemar to saistītajiem noteikumiem.
<b>Lietuvių [Lithuanian]</b>	Šiuo <i>[manufacturer name]</i> deklaruoja, kad šis <i>[equipment type]</i> atitinka esminius reikalavimus ir kitas 1999/5/EB Direktyvos nuostatas.
<b>[nl] Nederlands [Dutch]</b>	Hierbij verklaart <i>[naam van de fabrikant]</i> dat het toestel <i>[type van toestel]</i> in overeenstemming is met de essentiële eisen en de andere relevante bepalingen van richtlijn 1999/5/EG.
<b>[mt] Malti [Maltese]</b>	Hawnhekk, <i>[isem tal-manifattur]</i> , jiddikjara li dan <i>[il-mudel tal-prodott]</i> jikkonforma mal-htigijiet essenzjali u ma provvedimenti oħrajn rilevanti li hemm fid-Dirrettiva 1999/5/EC.
<b>[hu] Magyar [Hungarian]</b>	Alulírott, <i>[gyártó neve]</i> nyilatkozom, hogy a <i>[... típus]</i> megfelel a vonatkozó alapvető követelményeknek és az 1999/5/EC irányelv egyéb előírásainak.
<b>[pl] Polski [Polish]</b>	Niniejszym <i>[nazwa producenta]</i> oświadczam, że <i>[nazwa wyrobu]</i> jest zgodny z zasadniczymi wymogami oraz pozostałymi stosownymi postanowieniami Dyrektywy 1999/5/EC.
<b>[pt] Português [Portuguese]</b>	<i>[Nome do fabricante]</i> declara que este <i>[tipo de equipamento]</i> está conforme com os requisitos essenciais e outras disposições da Directiva 1999/5/CE.
<b>[sl] Slovensko [Slovenian]</b>	<i>[Ime proizvajalca]</i> izjavlja, da je ta <i>[tip opreme]</i> v skladu z bistvenimi zahtevami in ostalimi relevantnimi določili direktive 1999/5/ES.
<b>Slovensky [Slovak]</b>	<i>[Menovýrobcu]</i> týmto vyhlasuje, že <i>[typzariadenia]</i> spĺňa základné požiadavky a všetky príslušné ustanovenia Smernice 1999/5/ES.
<b>[fi] Suomi [Finnish]</b>	<i>[Valmistaja = manufacturer]</i> vakuuttaa täten että <i>[type of equipment = laitteen tyyppimerkintä]</i> tyyppinen laite on direktiivin 1999/5/EY oleellisten vaatimusten ja sitä koskevien direktiivin muiden ehtojen mukainen.
<b>[sv] Svenska [Swedish]</b>	Härmed intygar <i>[företag]</i> att denna <i>[utrustningstyp]</i> står i överensstämmelse med de väsentliga egenskapskrav och övriga relevanta bestämmelser som framgår av direktiv 1999/5/EG.

© Copyright 2017 Laird. All Rights Reserved. Patent pending. Any information furnished by Laird and its agents is believed to be accurate and reliable. All specifications are subject to change without notice. Responsibility for the use and application of Laird materials or products rests with the end user since Laird and its agents cannot be aware of all potential uses. Laird makes no warranties as to non-infringement nor as to the fitness, merchantability, or sustainability of any Laird materials or products for any specific or general uses. Laird, Laird Technologies, Inc., or any of its affiliates or agents shall not be liable for incidental or consequential damages of any kind. All Laird products are sold pursuant to the Laird Terms and Conditions of Sale in effect from time to time, a copy of which will be furnished upon request. When used as a tradename herein, Laird means Laird PLC or one or more subsidiaries of Laird PLC. Laird™, Laird Technologies™, corresponding logos, and other marks are trademarks or registered trademarks of Laird. Other marks may be the property of third parties. Nothing herein provides a license under any Laird or any third party intellectual property right.

## X-ON Electronics

Largest Supplier of Electrical and Electronic Components

*Click to view similar products for [Multiprotocol Development Tools](#) category:*

*Click to view products by [Laird Connectivity](#) manufacturer:*

Other Similar products are found below :

[CYW94343WWCD1\\_EVB](#) [MIKROE-2439](#) [XKC-M5T-W](#) [ATWINC3400-XPRO](#) [2636](#) [Gpy](#) [STEVAL-FKI001V1](#) [8265.NGWIMG.DTX1](#)  
[TEL0111](#) [SiPy 22 dBm](#) [ATWINC3400-XSTK](#) [RE-WFKIT-9260NVP](#) [2542](#) [irpi01-868](#) [irpi01-915](#) [BCM94343WWCD1\\_EVB](#) [INP3010](#)  
[INP3011](#) [ISM43340-L77-EVB](#) [ISMART43362-E](#) [ISP4520-AS-DK](#) [nRF9160-DK](#) [QPQ1906EVB-01](#) [102010129](#) [102991023](#) [107990093](#)  
[113990254](#) [SIMSA868C-Cloud-DKL](#) [SIMSA868-Cloud-DKL](#) [SIMSA915-Cloud-DKL](#) [SIMSA-DKL](#) [SKY66423-11EK2](#) [SKY66423-11EK1](#)  
[TEL0097](#) [80-000535](#) [DFR0505](#) [XKC-V1T-U](#) [FiPy](#) [453-00010-K1](#) [453-00011-K1](#) [DVK-RM186-SM-01](#) [XPC270300EK](#) [MIKROE-2440](#)  
[MTDOT-BOX-G-868-B](#) [LBEH5DU1BW-TEMP-DS-SD](#) [113030023](#) [SKY66420-11EK1](#) [SKY66420-11EK2](#) [SKY66420-11EK3](#) [SKY66423-11EK3](#)