

## Common Mode Choke for Automotive Signal Line CM Series

### FEATURES AND APPLICATIONS

Laird CM1210 CM1812 series automotive common mode chokes improve performance and reliability. A low profile and compact design benefits automotive electronics, industrial and telecom design. Products feature superior common mode noise suppression over broadband frequency and reduce customer total EMC cost. Chokes are designed in wire wound construction and perform in extended operating temperature range.

#### FEATURES

- Magnetic wire-wound structure
- Superior common mode noise suppression over broadband frequency
- Low profile and small size

#### APPLICATIONS

- Automotive CAN-BUS Signal Lines
- Telecom and Industrial Singal Lines

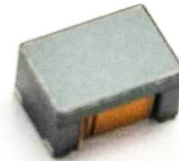

#### PART NUMBER EXPLANATION

<b>CM</b>	<b>1812</b>	<b>B</b>	<b>104R</b>	-	<b>1A</b>
Product series code	Dimension code	Material code	Inductance code		Automotive code

#### ELECTRICAL SPECIFICATIONS

- Reliability test for this part meets AEC-Q200 standard
- Inductance tested at 100KHz, 0.1Vrms
- Operating Temperature range :
  - CM1812B Series -55°C to +150°C (Including self - temperature rise )
  - CM1812A Series -40°C to +125°C (Including self - temperature rise )
  - CM1210C Series -55°C to +150°C (Including self - temperature rise )
  - CM1210B Series -55°C to +150°C (Including self - temperature rise )
  - CM1210A Series -40°C to +125°C (Including self - temperature rise )
- Humidity Range : 85±3% RH
- Storage temperature range (packaging conditions): -10°C~+40°C and RH 60%(MAX.)

1. CM1210 SERIES DIMENSIONS

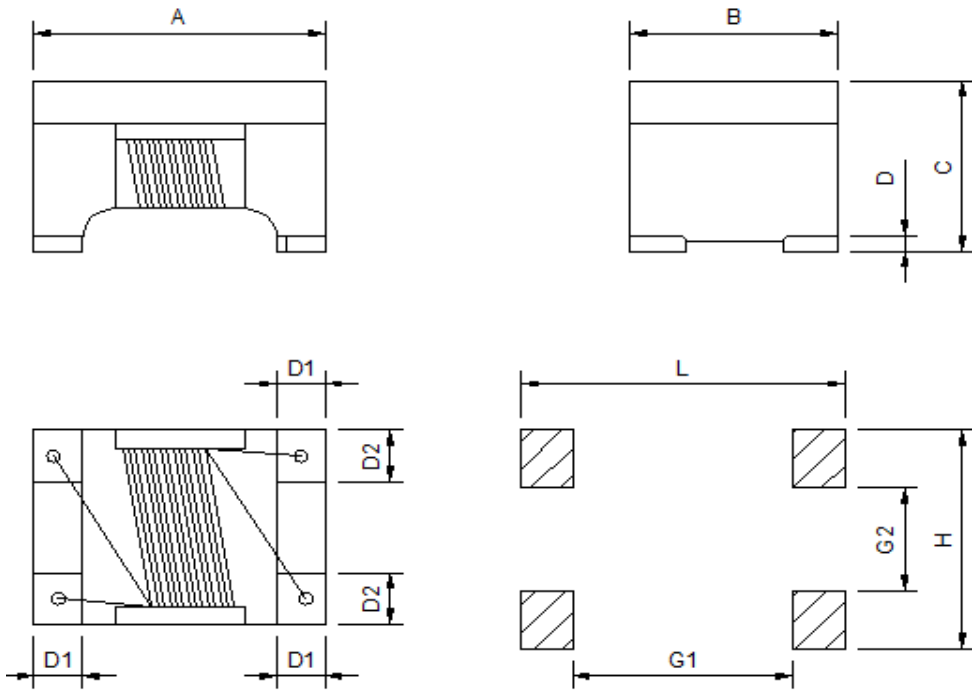

Recommended layout

CM1210 Series

A	B	C	D	D1	D2	L	H	G1	G2
3.20+0.3/-0.2	2.5±0.2	2.5 Max	0.3 Min	0.55±0.2	0.75±0.2	3.7 REF	2.8 REF	2.4 REF	1.2 REF

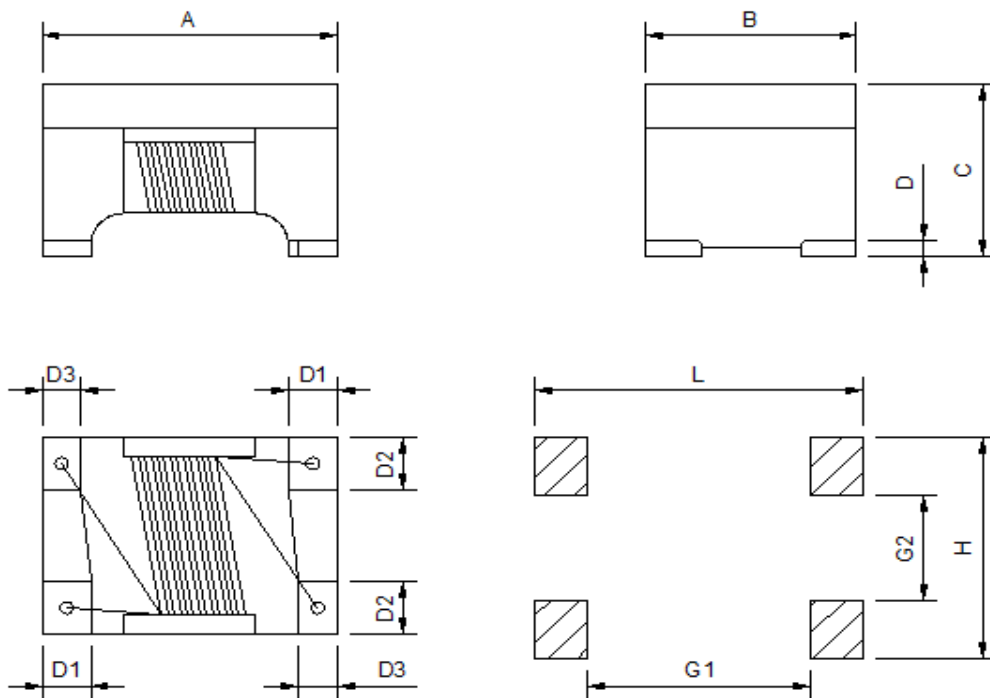

CM1812 Series

A	B	C	D	D1	D2	D3	L	H	G1	G2
4.5±0.2	3.2±0.2	2.8±0.2	0.4 Min	0.8±0.2	0.85±0.2	0.6±0.2	5.0 REF	3.6 REF	3.4 REF	1.7 REF

**2.SPECIFICATION**

Part No.	Common Mode Impedance(ohm) 10MHz		Inductance (uH) 0.1V/100KHz	DC Resistance (ohm) Max	Rated Current (A)	Rated Volt (Vdc)	IR (Mohm) Min
	Typ	Min					
CM1210C113R-1A	550	300	10 +50/-30%	0.4	0.30	80	10
CM1210B223R-1A	1100	500	22 +50/-30%	0.5	0.25	80	10
CM1210B513R-1A	2600	1000	51 +50/-30%	0.7	0.20	80	10
CM1210B104R-1A	5100	2200	100 +50/-30%	1.5	0.15	80	10
CM1210A204R-1A	---	---	200 +50/-10%	5.5	0.07	80	10

CM1812B113R-1A	600	300	11 +50/-30%	0.6	0.36	50	10
CM1812B223R-1A	1200	500	22 +50/-30%	1.0	0.31	50	10
CM1812B513R-1A	2800	1000	51 +50/-30%	1.0	0.23	50	10
CM1812B104R-1A	5800	2000	100 +50/-30%	2.0	0.20	50	10
CM1812A204R-1A	---	---	200 +60/-20%	4.5	0.10	50	10

**3.EQUIVALENT CIRCUIT**

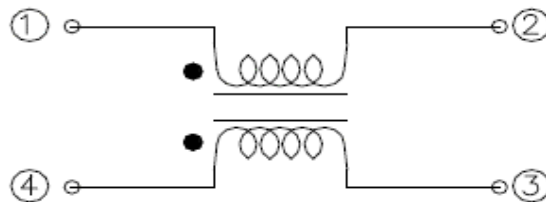

**4.MATERIAL LIST**

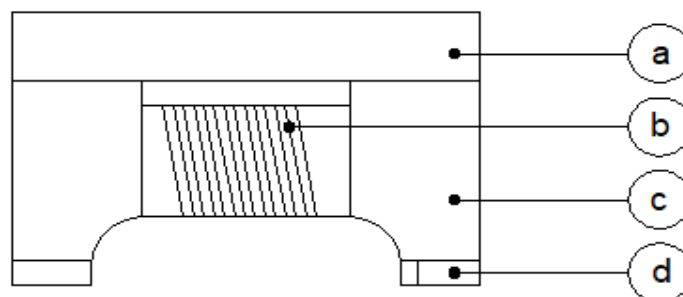

- (a) Upper Cover
- (b) Wire
- (c) Core
- (d) Terminal

5. CHARACTERISTICS CURVES

CM1210C113R-1A

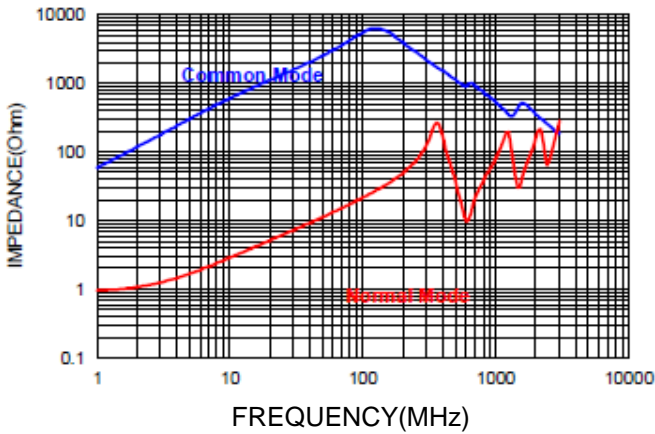

CM1210B223R-1A

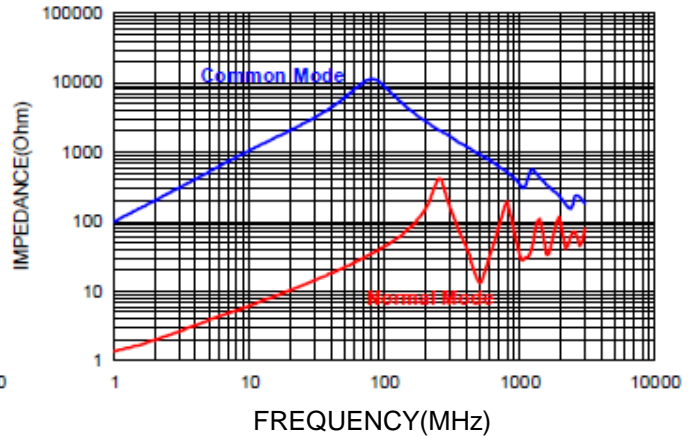

CM1210B513R-1A

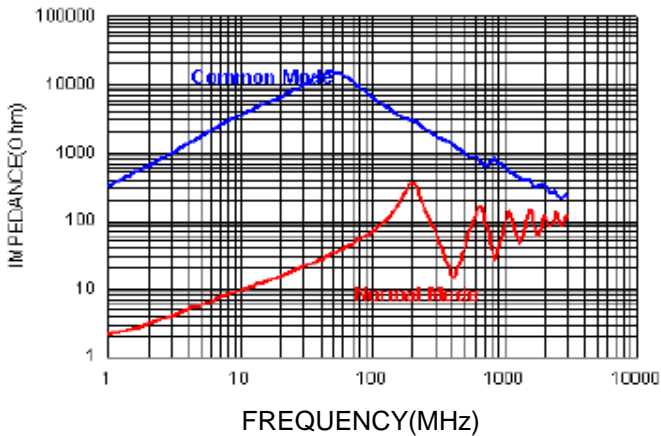

CM1210B104R-1A

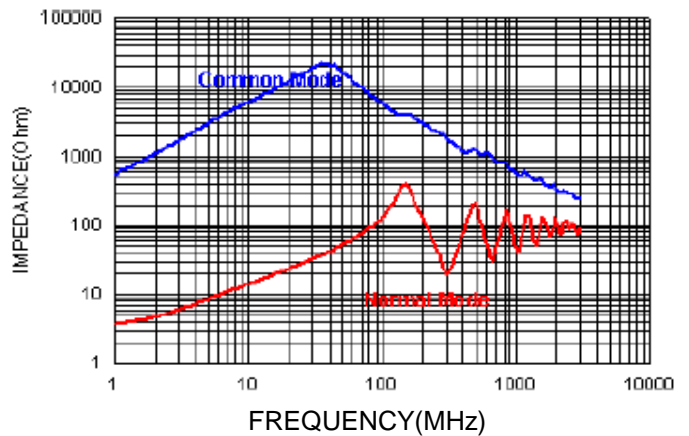

CM1210A204R-1A

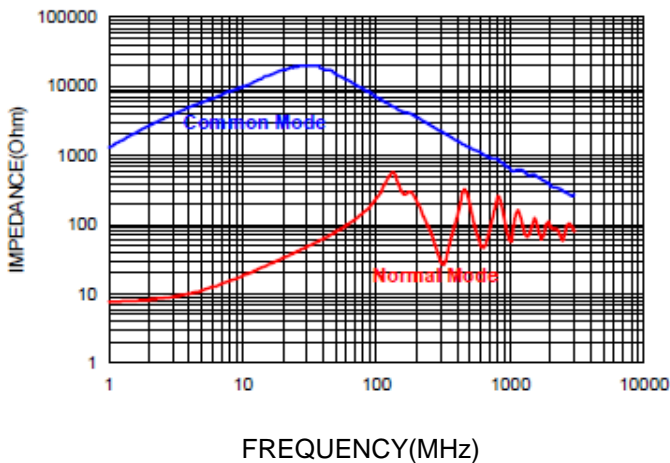

5. CHARACTERISTICS CURVES

CM1812B113R-1A

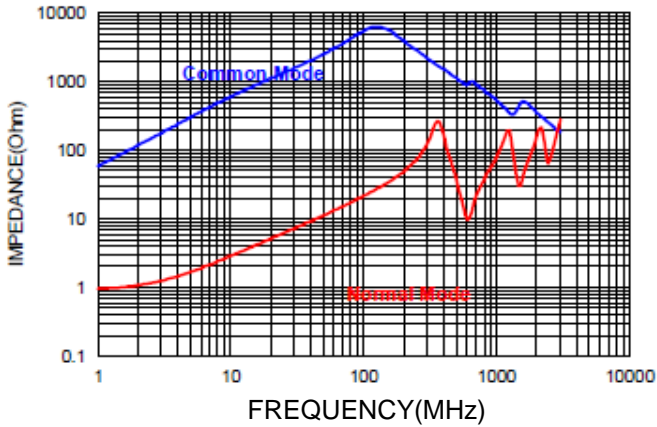

CM1812B223R-1A

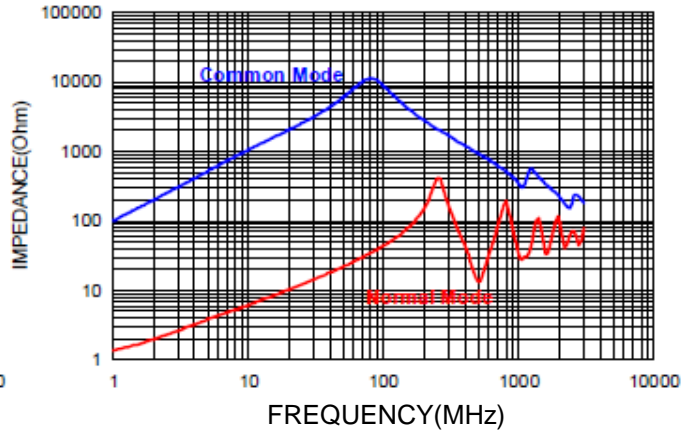

CM1812B513R-1A

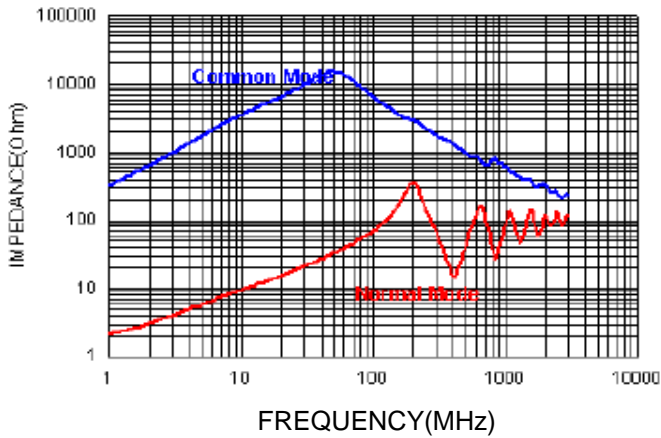

CM1812B104R-1A

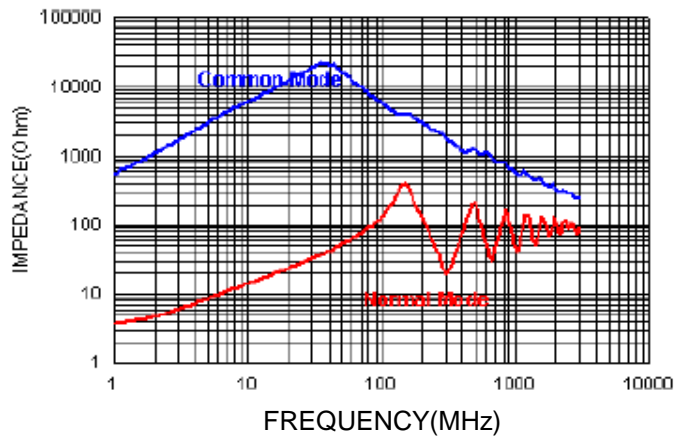

CM1812A204R-1A

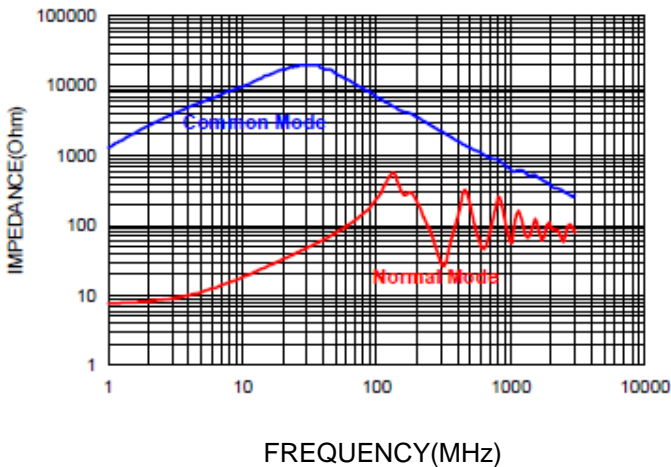

6. SOLDERING

Mildly activated rosin fluxes are preferred.

Recommended temperature profiles for re - flow soldering in Figure 1 .

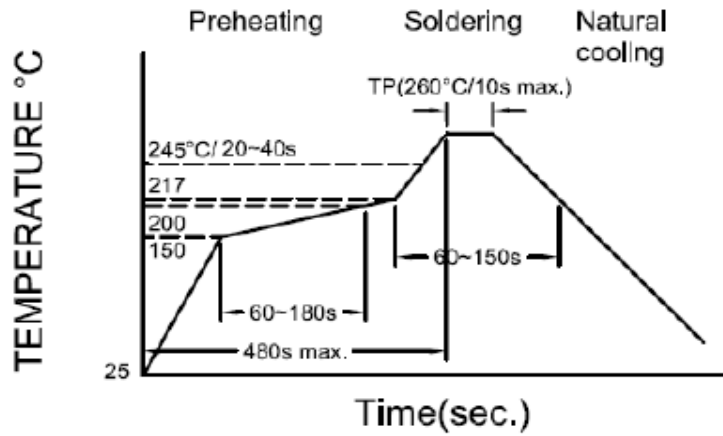
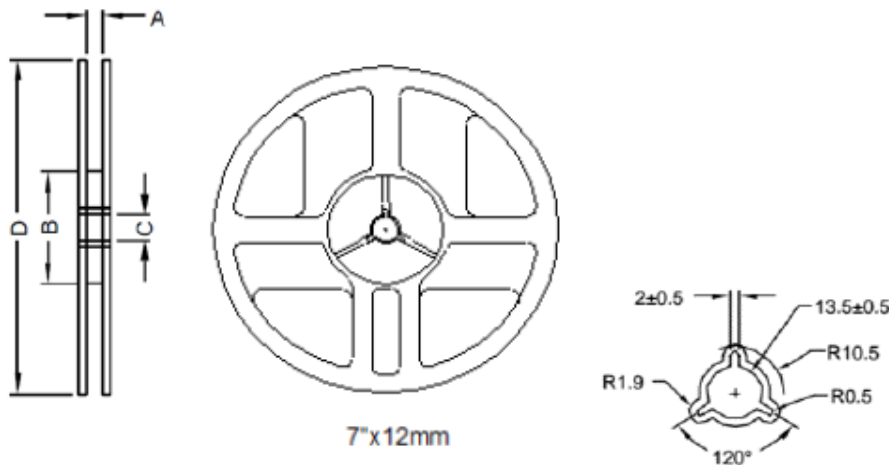

Figure 1. : Re-flow Soldering time  
3 times Max.

7. PACKAGING

7-1 Reel Dimension



Size	Type	A(mm)	B(mm)	C(mm)	D(mm)
CM1210	7"x8mm	9.0±0.5	60.0±2.0	13.5±0.5	178.0±2.0
CM1812	7"x12mm	13.5±0.5	60.0±2.0	13.5±0.5	178.0±2.0

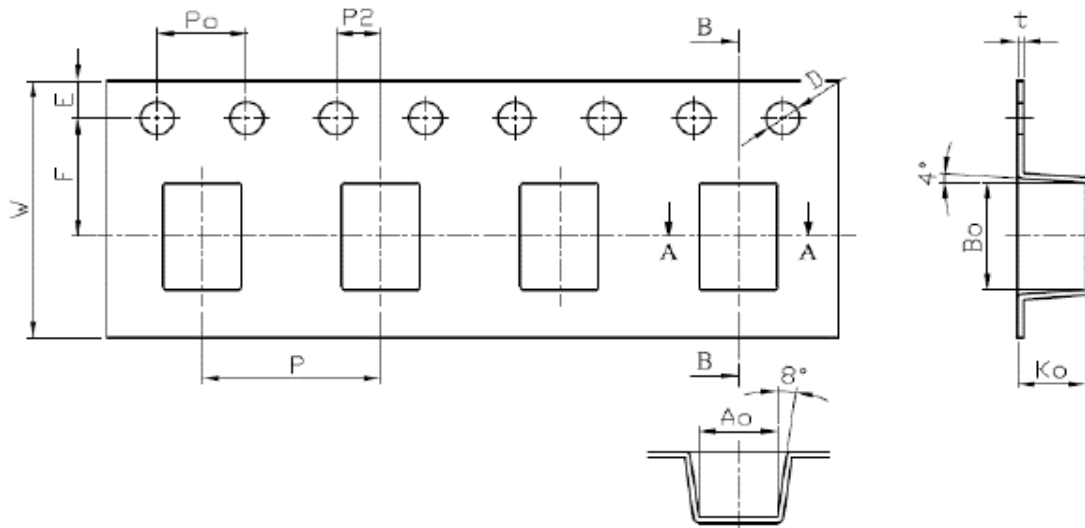

Size	P(mm)	P0(mm)	P2(mm)	B0(mm)	A0(mm)	K0(mm)	D(mm)	E(mm)	F(mm)	W(mm)	T(mm)
CM1210	4.0±0.1	4.0±0.1	2.0±0.1	4.9±0.1	3.6±0.1	3.0±0.1	1.05+0.1/-0	1.75±0.1	5.5±0.05	12.0±0.1	0.26±0.05
CM1812	8.0±0.1	4.0±0.1	2.0±0.1	3.65±0.1	2.88±0.1	2.5±0.1	1.05+0.1/-0	1.75±0.1	3.5±0.05	8.0±0.1	0.26±0.05

Size	Reel	Inner Box	Outer Box
CM1210	2000	10000	50000
CM1812	500	2000	10000

## 7-2 Tearing Off Force

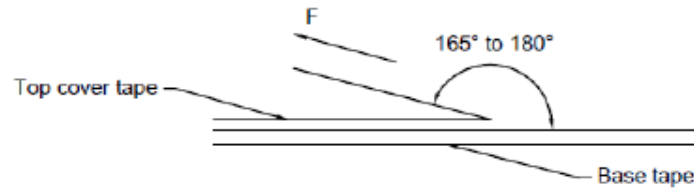

The force for tearing off cover tape is 10~100 grame in the arrow direction under the following conditions .

Room Temp (°C)	Room Humidity(%)	Room atm (hPa)	Tearing Speed mm/min
5~35	45~85	860~1060	300

## 8. Application Notice:

### 1.Storage Conditions:

To maintain the solderability of terminal electrodes:

- a) Recommended products should be used within 12 months from the time of delivery .
- b) The packaging material should be kept where no chlorine or sulfur exists in the air .

### 2. Transportation:

- a) Products should be -handled with care to avoid damage or contamination from perspiration and skin oils .
- b) Vacuum pick up is strongly recommended for individual components .
- c) Bulk handling should ensure that abrasion and mechanical shock are minimized .



## X-ON Electronics

Largest Supplier of Electrical and Electronic Components

*Click to view similar products for* [Common Mode Chokes / Filters](#) *category:*

*Click to view products by* [Laird Performance Materials](#) *manufacturer:*

Other Similar products are found below :

[74279408](#) [PE-62911NL](#) [PE-64683](#) [ST6118T-R](#) [T8114NLT](#) [RD5122-10-6M0](#) [TCM0806G-350-2P-T](#) [TCM0806G-650-2P-T](#) [IND-0110](#)  
[UAL21V07012500](#) [UAL21VR0802000](#) [UAL24VR06500CH](#) [UALSC023000000](#) [UALSC1020JH000](#) [UALSC1520JH000](#)  
[UALSU16VD30030](#) [UALSU16VD40010](#) [UALSU9H0305000](#) [UALSU9HF060300](#) [UALSU9VD070100](#) [36-00037](#) [5701610000](#)  
[UALW21HS072450](#) [UALSU9VD070400](#) [UALSU9HF050500](#) [UALSU9H0208000](#) [UALSCF25081300](#) [UAL24VK06450CH](#)  
[PLT10HH501100PNB](#) [PLT10HH401100PNB](#) [PLT10HH1026R0PNB](#) [PE-67531](#) [EXC-X4CH120X](#) [TLH10UB 113 0R5](#) [2752041447](#)  
[2752045447](#) [CMS3-11-R](#) [7351V](#) [CMF16-153131](#) [744252510](#) [T8116NLT](#) [FE2X10-4-2NL](#) [744253200](#) [744253101](#) [744252220](#) [TX8111NLT](#)  
[UAL30VR3500470](#) [CTX01-19077-R](#) [T8003NLT](#) [CTX01-13663](#)