



SF51G THRU SF58G

VOLTAGE RANGE

50 to 600 Volts

CURRENT

5.0 Ampere

Features

- Super fast switching speed
- Glass passivated chip junction
- Low power loss, high efficiency
- Low leakage
- High Surge Capacity
- High temperature soldering guaranteed
260°C/10 seconds, 0.375"(9.5mm) lead length

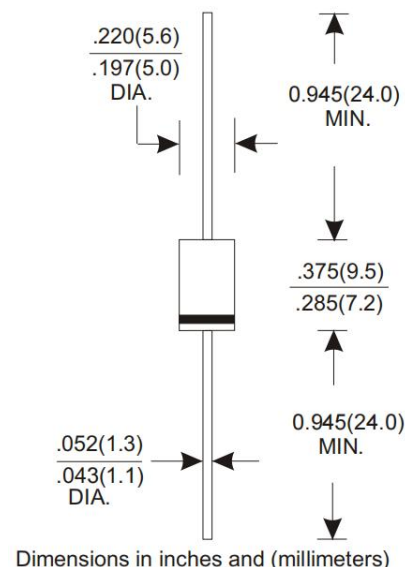

Mechanical Data

- Case: Transfer molded plastic
- Epoxy: UL94V-0 rate flame retardant
- Polarity: Color band denotes cathode end
- Lead: Plated axial lead, solderable per MIL-STD-202E method 208C
- Mounting position: Any
- Weight: 0.042ounce, 1.19 gram

Maximum Ratings and Electrical Characteristics

- Ratings at 25°C ambient temperature unless otherwise specified
- Single Phase, half wave, 60Hz, resistive or inductive load
- For capacitive load derate current by 20%

TYPE NUMBER	SYMBOL	SF 51G	SF 52G	SF 53G	SF 54G	SF 55G	SF 56G	SF 57G	SF 58G	UNIT
Maximum Repetitive Peak Reverse Voltage	V_{RRM}	50	100	150	200	300	400	500	600	Volts
Maximum RMS Voltage	V_{RMS}	35	70	105	140	210	280	350	420	Volts
Maximum DC Blocking Voltage	V_{DC}	50	100	100	200	300	400	500	600	Volts
Maximum Average Forward Rectified Current 0.375"(9.5mm) lead length at $T_A=125^\circ\text{C}$	$I_{(AV)}$	5.0								Amps
Peak Forward Surge Current 8.3mS single half sine wave superimposed on rated load (JEDEC method)	I_{FSM}	150								Amps
Maximum Instantaneous Forward Voltage at 5.0A	V_F	0.95			1.25		1.70			Volts
Maximum DC Reverse Current at rated DC blocking Voltage at	$T_A = 25^\circ\text{C}$	5.0								μA
	$T_A = 125^\circ\text{C}$	120								
Maximum Reverse Recovery Time ^(NOTE 1)	T_{RR}	35								nS
Typical Junction Capacitance ^(NOTE 2)	C_j	50				30				pF
Typical Thermal Resistance ^(NOTE 3)	$R_{\theta JA}$	30								$^\circ\text{C}/\text{W}$
Operating Junction Temperature Range	T_j	-55 to +150								$^\circ\text{C}$
Storage Temperature Range	T_{STG}	-55 to +150								$^\circ\text{C}$

Notes:

1. Reverse Recovery Test Conditions: $I_f=0.5\text{A}$, $I_r=1.0\text{A}$, $I_{rr}=0.25\text{A}$.
2. Measured at 1.0MHz and applied reverse voltage of 4.0 Volts.
3. Thermal Resistance from Junction to Ambient with 0.375"(9.5mm) lead length, PCB mounted.



SF51G THRU SF58G

VOLTAGE RANGE 50 to 600 Volts

CURRENT 5.0 Ampere

Ratings and Characteristic Curves (T_A=25°C unless otherwise noted)

FIG.1-TYPICAL FORWARD CURRENT DERATING CURVE

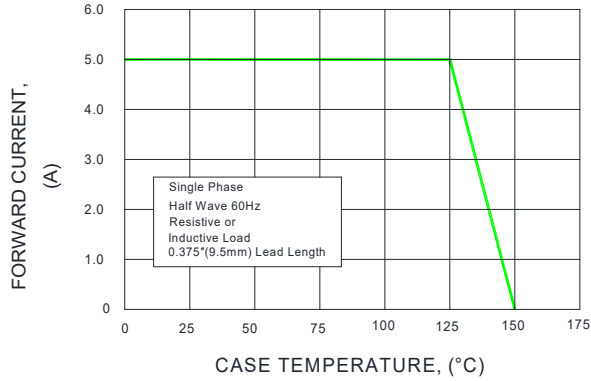

FIG.2-MAXIMUM NON-REPETITIVE PEAK FORWARD SURGE CURRENT

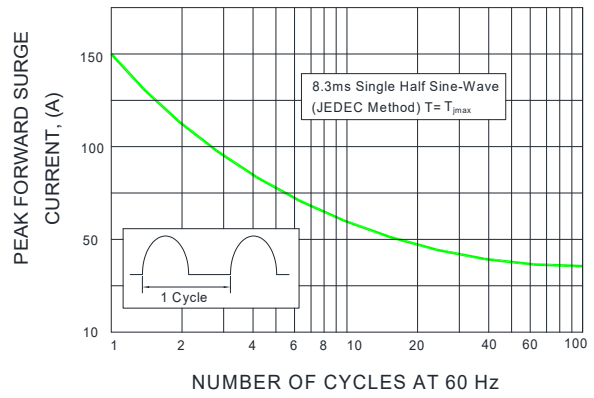

FIG.3-TYPICAL INSTANTANEOUS FORWARD CHARACTERISTICS

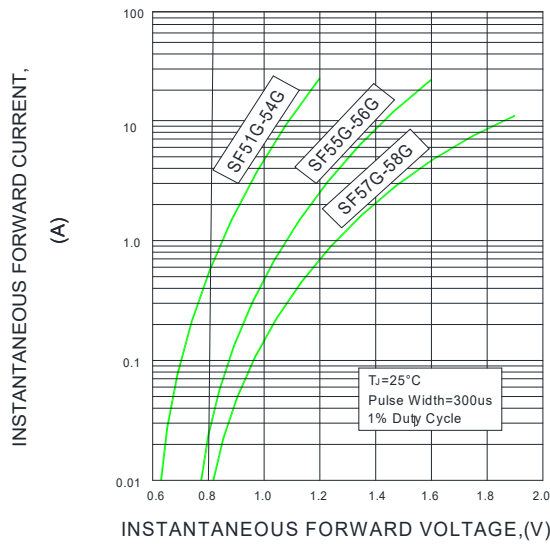

FIG.4-TYPICAL REVERSE CHARACTERISTICS

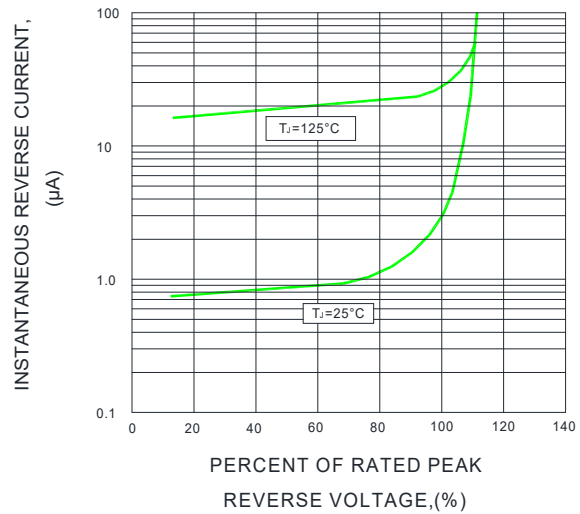

FIG.5-TYPICAL JUNCTION CAPACITANCE

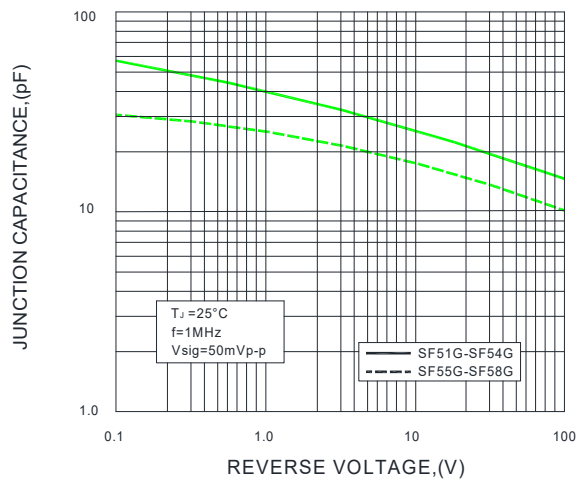
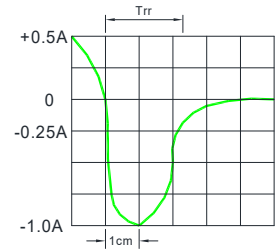
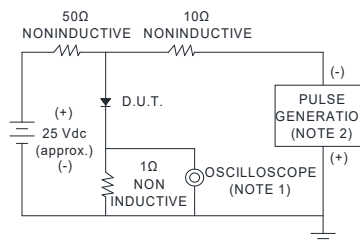

FIG.6-TEST CIRCUIT DIAGRAM AND REVERSE RECOVERY TIME CHARACTERISTIC



- NOTES : 1.Rise Time=7ns mas. Input Impedance= 1 magohm. 22pF
- 2.Rise time=10ns max. Source Impedance= 50 ohms

SET TIME BASE FOR 50/100ns/cm



Axial Lead Taping Specifications for Rectifiers

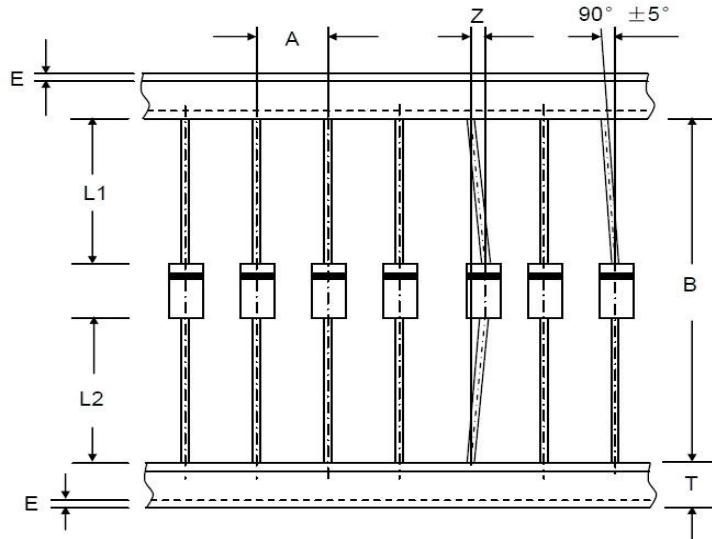

Component Outline	Component Pitch A	Inner Tape Pitch B	Cumulative Tolerance
	±0.5mm	+0.5mm -0.4mm	
DO-201AD(DO-27)	10.0mm	52.4mm	2.0mm/20pitch

Item	Symbol	Specifications(mm)	Specifications(inch)
Component alignment	Z	1.2 max	0.048 max
Tape width	T	6.0±0.4	0.236±0.016
Exposed adhesive	E	0.8 max	0.032 max
Body eccentricity	L1-L2	1.0 max	0.040 max



Reflow Profile

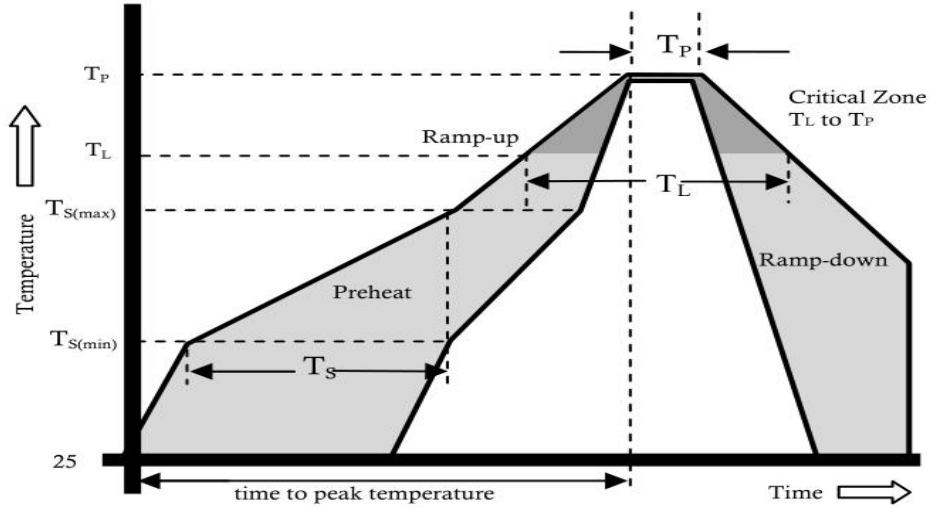

Reflow Condition		Pb-Free Assembly
Pre Heat	Temperature Min.	+150°C
	Temperature Max.	+200°C
	Time(Min to Max)	60-180 secs.
Average ramp up rate(Liquidus Temp(T_L) to peak)		3°C/sec. Max.
TS(max) to TL - Ramp-up Rate		3°C/sec. Max.
Reflow	Temperature (T_L)(Liquidus)	+217°C
	Temperature (T_L)	60-150 secs.
Peak Temp (T_P)		+(260+0/-5)°C
Time within 5°C of actual Peak Temp (T_P)		25 secs.
Ramp-down Rate		6°C/sec. Max.
Time 25°C to peak Temp (T_P)		8 min. Max.
Do not exceed		+260°C



SF51G THRU SF58G

VOLTAGE RANGE	50 to 600 Volts
CURRENT	5.0 Ampere

Disclaimer

The information presented in this document is for reference only. Chongqing changjie Electronic Technology Co., Ltd. reserves the right to make changes without notice for the specification of the products displayed herein to improve reliability, function or design or otherwise.

The product listed herein is designed to be used with ordinary electronic equipment or devices, and not designed to be used with equipment or devices which require high level of reliability and the malfunction of which would directly endanger human life (such as medical instruments, transportation equipment, aerospace machinery, nuclear-reactor controllers, fuel controllers and other safety devices), Changjie or anyone on its behalf, assumes no responsibility or liability for any damages resulting from such improper use of sale.

This publication supersedes & replaces all information previously supplied. For additional information, please visit our website [http:// www.czlangjie.com](http://www.czlangjie.com) , or consult your nearest Langjie's sales office for further assistance.

X-ON Electronics

Largest Supplier of Electrical and Electronic Components

Click to view similar products for [Rectifiers](#) category:

Click to view products by [LangJie](#) manufacturer:

Other Similar products are found below :

[70HFR40](#) [FR105 R0](#) [RL252-TP](#) [1N5397](#) [1N4005-TR](#) [1N4007-BP](#) [UFS120Je3/TR13](#) [20ETS12S](#) [RRE02VS6SGTR](#) [MS306](#) [A1N5404G-G](#)
[CRF02\(T5L,TEMQ\)](#) [ACGRB207-HF](#) [CLH07\(TE16L,Q\)](#) [CLH03\(TE16L,Q\)](#) [1N5395-TP](#) [UES1302](#) [ACGRC307-HF](#) [ACEFC304-HF](#) [DZ-](#)
[1380](#) [85HFR60](#) [40HFR60](#) [70HF120](#) [85HFR80](#) [SCF7500](#) [SM100](#) [ACGRA4001-HF](#) [SKN70/08](#) [NTE5819](#) [NTE5827](#) [NTE5828](#) [NTE5911](#)
[NTE5915](#) [NTE6104](#) [NTE6163](#) [NTE6164](#) [NTE6165](#) [NTE6364](#) [TSD3G](#) [SET130312](#) [NRVUS110VT3G](#) [UES1106](#) [UES1306](#)
[NRVUS240VT3G](#) [D5FE60-5063](#) [R4000GPS-TP](#) [D4015L56TP](#) [UES1306HR2](#) [FX20K120](#) [D20XB60-7101](#)