

EL-SGD 70-ATP

Four-Channel Temperature Data Logger with 7" Capacitive Touch Display

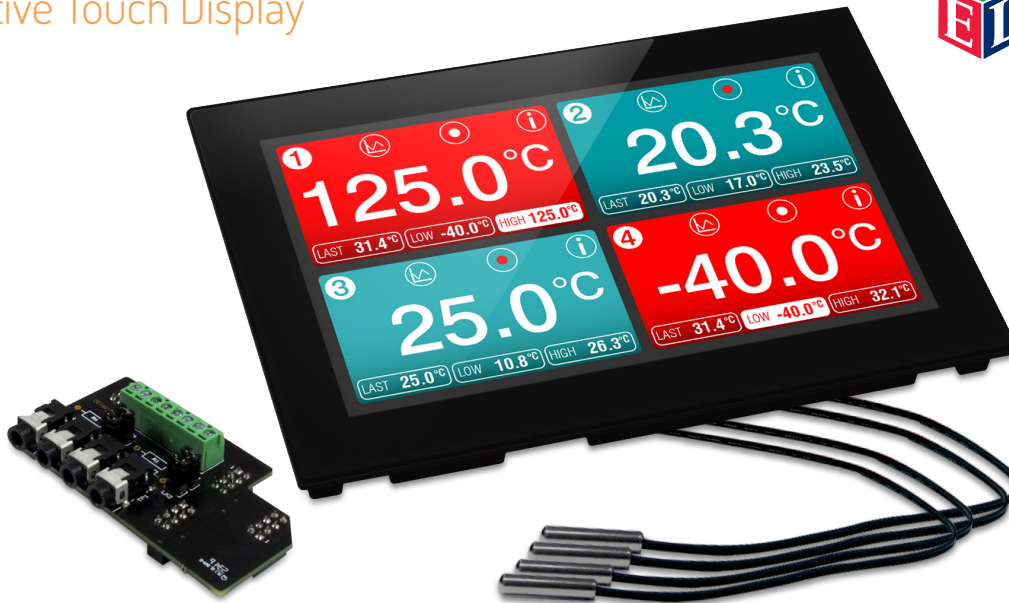

EL-SGD 70-ATP is a four-channel temperature data logger with real-time readings, trend graphing and data analysis tools.

The EL-SGD 70-ATP is a four-channel temperature data logger based on Lascar's PanelPilotACE platform. The product includes a 7" panel mounted display module with capacitive touch screen, a four-channel thermistor temperature board and compatible temperature probes. The user interface comprises an advanced logging application which shows real-time readings for up to four temperature channels, live trend graphs and access to a suite of real-time data analysis information.

The logger can store up to 100,000 readings per channel at sample rates from 15 seconds up to 12 hours. Data can be downloaded via USB using Lascar's free Device Utility software, which is available from:

www.lascarelectronics.com/software/panelpilotace

For advanced users, the interface can be extensively customised using Lascar's free drag-and-drop PanelPilotACE Design Studio software.

Each EL-SGD 70-ATP includes:

- 7" PanelPilotACE display with mounting kit (SGD 70-A)
- Four-channel thermistor add-on board (S70-TP)
- 4 x 1m thermistor probe with 3.5mm plug (EL-PROBE2-1.0M-TP)
- Mini USB cable (CABLE USB A-MF)

Specifications

Supplied probe measurement range	-40°C to +125°C (-40°F to +257°F)
Internal Resolution	0.01°C (0.01°F)
Temperature Accuracy	±1.0°C (±1.8°F)*
Number of Readings (per channel)	100,000
Logging Rate	15 seconds to 12 hours
Number of Channels	Up to 4
Outside Dimensions	186 x 122 x 21 mm (7.3" x 4.8" x 0.8")
Communications Protocols	USB

* Between -5°C and 40°C without offset calibration. Between -40°C and +125°C with offset calibration applied.



www.lascarelectronics.com



EL-SGD 70-ATP

Four-Channel Temperature Data Logger with 7" Capacitive Touch Display



Operating Modes

The EL-SGD 70-ATP can be configured for one, two, three or four channel temperature data logging in either celsius or fahrenheit.

Function	3.5mm SKT	Configuration
Channel 1	NTC1	1, 2, 3 or 4 channel operation
Channel 2	NTC2	2, 3 or 4 channel operation
Channel 3	NTC3	3 or 4 channel operation
Channel 4	NTC4	4 channel operation only

Software

Device Utility

Data download, device updates and programming of the module is completed using the free Device Utility software available from: www.lascarelectronics.com/software/panelpilotace. Data is downloaded in comma separated variable format which can be imported into spreadsheet packages for graphing and further analysis.

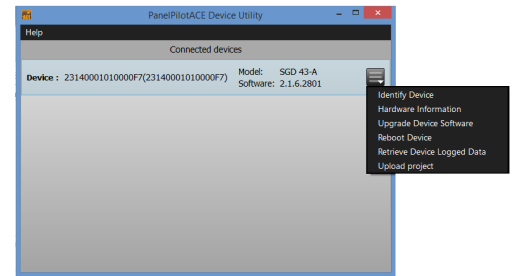

Retrieving Logged Data

The EL-SGD 70-ATP is configured as a USB slave. To retrieve logged data, connect a PC or laptop to the USB connector on the rear of the unit and use the Device Utility software to select and extract logs as .txt files.

Design Studio Software

The PanelPilotACE Design Studio software provides tools for advanced users who wish to fully customise the data logging functionality of the module. Visit <https://www.lascarelectronics.com/software/panelpilotace> or www.youtube.com/panelpilot for further information including learning materials on getting started with this powerful drag-and-drop software suite.

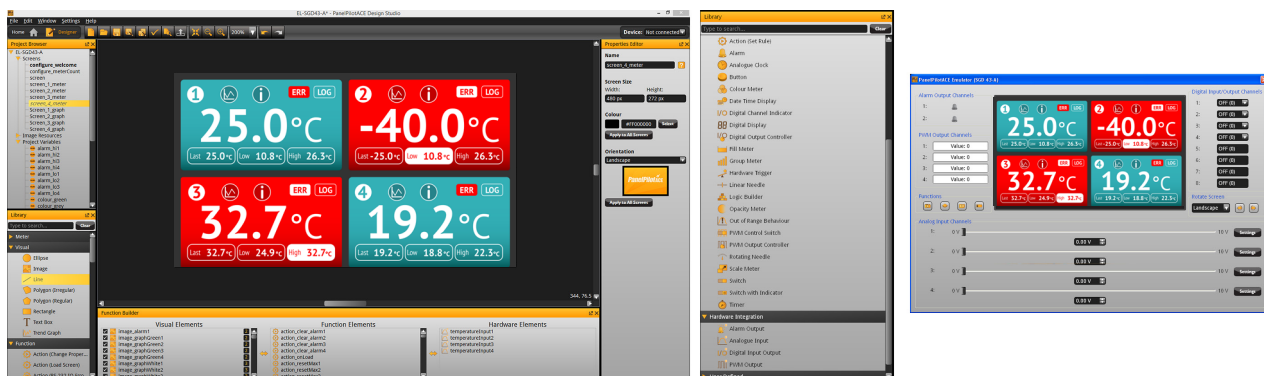

EL-SGD 70-ATP

Four-Channel Temperature Data Logger with 7" Capacitive Touch Display



Dimensions and Mounting

All dimensions are in mm (in)

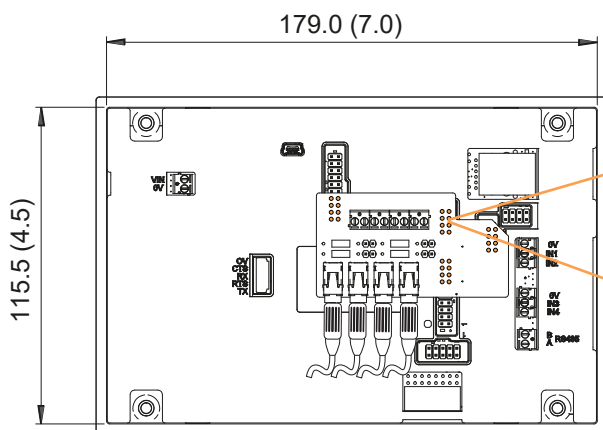
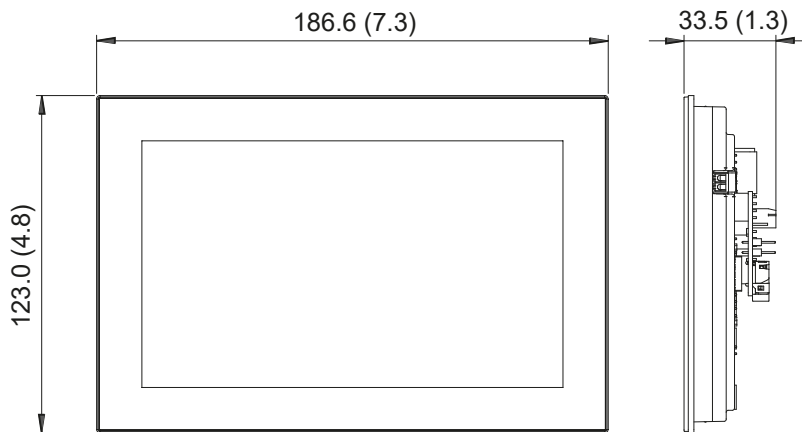

The orange colour pins on the rear elevation (below) show the correct location for the S70-TP temperature board.

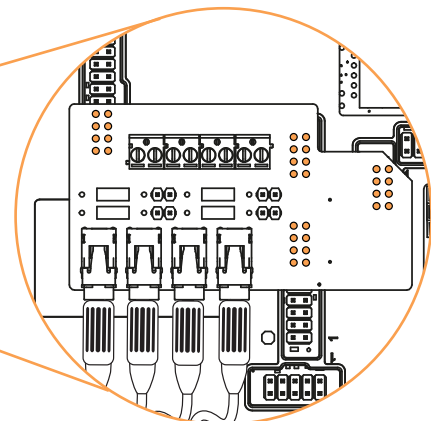

Panel Cut-Out and Fitting

The panel cut-out is 179 x 115.5 mm (7.0" x 4.54"). The module can be mounted in panels between 0.5 and 4.0 mm (0.01" and 0.15") in thickness.

To do this take the four bracket clips supplied and use the screws to secure these to the mounting holes located on the rear of the module.

Then place the module in the panel and tighten the grub screws located in each bracket to secure the module within the panel.

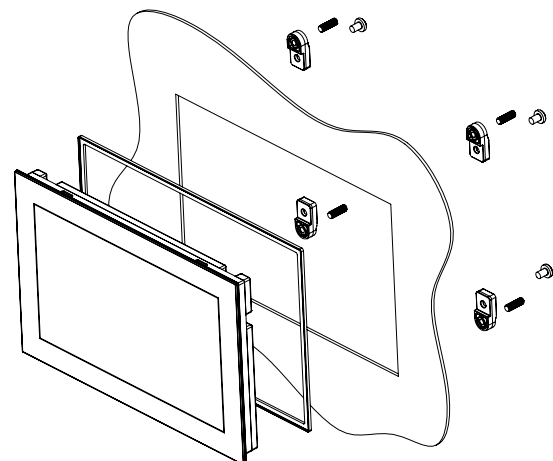

X-ON Electronics

Largest Supplier of Electrical and Electronic Components

Click to view similar products for [Lascar manufacturer](#):

Other Similar products are found below :

[EL-USB-5](#) [SGD 43-A](#) [SGD 35-M](#) [EL-USB-2-LCD+](#) [SGD28-M](#) [EL-SMS-2G-TP](#) [EL-WIFI-TP+-PROBE-G](#) [EL-MOTE-PROBE-3M-75-TP](#)
[EL-MOTE-WALL-BRACKET](#) [EL-MOTE-T-PLUS](#) [EL-SIE-2](#) [EL-SIE-6+](#) [EL-GFX-1](#) [EL-USB-TC](#) [EL-USB-RT](#) [EL-WIFI-TH+](#) [SP400-](#)
[BLUE](#) [SGD 70-A DK+](#) [EL-CC-2-001 PK10](#) [EL-CC-2-005 PK10](#) [EL-CC-1-001 PK10](#) [S70-TP](#) [SGD24-M-IP](#) [SGD24-M-IP420](#) [EL-SGD43-](#)
[ATP](#) [EL-USB-3](#) [EM32-1B](#) [SGD21-B](#) [EL-CC-2-002 PK10](#) [EL-CC-1-002 PK10](#) [CABLE USB A-SIL5](#) [DPM3AS-BL](#) [EL-USB-CO](#) [EMT1900](#)
[EL-WIFI-ALERT](#) [EL-ENVIROPAD-TC](#) [SP300](#) [EL-WIFI-DTC](#) [BEZ900-IP](#) [PSU20105](#) [SGD 70-A](#) [EL-WIFI-21CFR-TH](#) [EL-WIFI-21CFR-](#)
[TP+](#) [EL-GFX-DTP+](#) [EL-USB-ACT](#) [EL-CC-2-004 PK10](#) [EL-SMS-2G-PROBE-G](#) [EL-USB-TP-LCD-PROBE-G](#) [EL-CC-1-003 PK10](#) [SGD](#)
[24-M-IP420](#)