



iCE40 UltraPlus Breakout Board

User Guide

FPGA-UG-02001 Version 1.1

March 2017

Copyright Notice

Copyright © 2017 Lattice Semiconductor Corporation. All rights reserved. The contents of these materials contain proprietary and confidential information (including trade secrets, copyright, and other Intellectual Property interests) of Lattice Semiconductor Corporation and/or its affiliates. All rights are reserved. You are permitted to use this document and any information contained therein expressly and only for bona fide non-commercial evaluation of products and/or services from Lattice Semiconductor Corporation or its affiliates; and only in connection with your bona fide consideration of purchase or license of products or services from Lattice Semiconductor Corporation or its affiliates, and only in accordance with the terms and conditions stipulated. Contents, (in whole or in part) may not be reproduced, downloaded, disseminated, published, or transferred in any form or by any means, except with the prior written permission of Lattice Semiconductor Corporation and/or its affiliates. Copyright infringement is a violation of federal law subject to criminal and civil penalties. You have no right to copy, modify, create derivative works of, transfer, sublicense, publicly display, distribute or otherwise make these materials available, in whole or in part, to any third party. You are not permitted to reverse engineer, disassemble, or decompile any device or object code provided herewith. Lattice Semiconductor Corporation reserves the right to revoke these permissions and require the destruction or return of any and all Lattice Semiconductor Corporation proprietary materials and/or data.

Patents

The subject matter described herein may contain one or more inventions claimed in patents or patents pending owned by Lattice Semiconductor Corporation and/or its affiliates.

Trademark Acknowledgment

Lattice Semiconductor Corporation®, the Lattice Semiconductor logo, Silicon Image®, the Silicon Image logo, Instaport®, the Instaport logo, InstaPrevue®, Simplay®, Simplay HD®, the Simplay HD logo, Simplay Labs™, the Simplay Labs logo, the SiBEAM Snap™, the SiBEAM Snap logo, UltraGig™, the UltraGig logo are trademarks or registered trademarks of Lattice Semiconductor Corporation in the United States and/or other countries. HDMI® and the HDMI logo with High-Definition Multimedia Interface are trademarks or registered trademarks of, and are used under license from, HDMI Licensing, LLC. in the United States or other countries. MHL® and the MHL logo with Mobile High-Definition Link are trademarks or registered trademarks of, and are used under license from, MHL, LLC. in the United States and/or other countries. WirelessHD®, the WirelessHD logo, WiHD® and the WiHD logo are trademarks, registered trademarks or service marks of SiBeam, Inc. in the United States or other countries.

HDMI Licensing, LLC; MHL, LLC; Simplay Labs, LLC; and SiBeam, Inc. are wholly owned subsidiaries of Lattice Semiconductor Corporation.

All other trademarks and registered trademarks are the property of their respective owners in the United States or other countries. The absence of a trademark symbol does not constitute a waiver of Lattice Semiconductor's trademarks or other intellectual property rights with regard to a product name, logo or slogan.

Export Controlled Document

This document contains materials that are subject to the U.S. Export Administration Regulations and may also be subject to additional export control laws and regulations (collectively "Export Laws") and may be used only in compliance with such Export Laws. Unless otherwise authorized by an officer of Lattice Semiconductor Corporation in writing, this document and the information contained herein (a) may not be used in relation to nuclear, biological or chemical weapons, or missiles capable of delivering these weapons, and (b) may not be re-exported or otherwise transferred to a third party who is known or suspected to be involved in relation to nuclear, biological or chemical weapons, or missiles capable of delivering these weapons, or to any sanctioned persons or entities.

Further Information

To request other materials, documentation, and information, contact your local Lattice Semiconductor sales office or visit the Lattice Semiconductor web site at www.latticesemi.com.

Disclaimers

These materials are provided on an "AS IS" basis. Lattice Semiconductor Corporation and its affiliates disclaim all representations and warranties (express, implied, statutory or otherwise), including but not limited to: (i) all implied warranties of merchantability, fitness for a particular purpose, and/or non-infringement of third party rights; (ii) all warranties arising out of course-of-dealing, usage, and/or trade; and (iii) all warranties that the information or results provided in, or that may be obtained from use of, the materials are accurate, reliable, complete, up-to-date, or produce specific outcomes. Lattice Semiconductor Corporation and its affiliates assume no liability or responsibility for any errors or omissions in these materials, makes no commitment or warranty to correct any such errors or omissions or update or keep current the information contained in these materials, and expressly disclaims all direct, indirect, special, incidental, consequential, reliance and punitive damages, including WITHOUT LIMITATION any loss of profits arising out of your access to, use or interpretation of, or actions taken or not taken based on the content of these materials. Lattice Semiconductor Corporation and its affiliates reserve the right, without notice, to periodically modify the information in these materials, and to add to, delete, and/or change any of this information.

Products and Services

The products and services described in these materials, and any other information, services, designs, know-how and/or products provided by Lattice Semiconductor Corporation and/or its affiliates are provided on "AS IS" basis, except to the extent that Lattice Semiconductor Corporation and/or its affiliates provides an applicable written limited warranty in its standard form license agreements, standard Terms and Conditions of Sale and Service or its other applicable standard form agreements, in which case such limited warranty shall apply and shall govern in lieu of all other warranties (express, statutory, or implied). EXCEPT FOR SUCH LIMITED WARRANTY, LATTICE SEMICONDUCTOR CORPORATION AND ITS AFFILIATES DISCLAIM ALL REPRESENTATIONS AND WARRANTIES (EXPRESS, IMPLIED, STATUTORY OR OTHERWISE), REGARDING THE INFORMATION, SERVICES, DESIGNS, KNOW-HOW AND PRODUCTS PROVIDED BY LATTICE SEMICONDUCTOR CORPORATION AND/OR ITS AFFILIATES, INCLUDING BUT NOT LIMITED TO, ALL IMPLIED WARRANTIES OF MERCHANTABILITY, FITNESS FOR A PARTICULAR PURPOSE, AND/OR NON-INFRINGEMENT OF THIRD PARTY RIGHTS. YOU ACKNOWLEDGE AND AGREE THAT SUCH INFORMATION, SERVICES, DESIGNS, KNOW-HOW AND PRODUCTS HAVE NOT BEEN DESIGNED, TESTED, OR MANUFACTURED FOR USE OR RESALE IN SYSTEMS WHERE THE FAILURE, MALFUNCTION, OR ANY INACCURACY OF THESE ITEMS CARRIES A RISK OF DEATH OR SERIOUS BODILY INJURY, INCLUDING, BUT NOT LIMITED TO, USE IN NUCLEAR FACILITIES, AIRCRAFT NAVIGATION OR COMMUNICATION, EMERGENCY SYSTEMS, OR OTHER SYSTEMS WITH A SIMILAR DEGREE OF POTENTIAL HAZARD. NO PERSON IS AUTHORIZED TO MAKE ANY OTHER WARRANTY OR REPRESENTATION CONCERNING THE PERFORMANCE OF THE INFORMATION, PRODUCTS, KNOW-HOW, DESIGNS OR SERVICES OTHER THAN AS PROVIDED IN THESE TERMS AND CONDITIONS.

Contents

1. Introduction	5
2. Features	6
3. iCE40 UltraPlus Device	7
4. Software Requirements	8
5. Demonstration Design Shunts	9
6. Clock Sources	10
7. Board Power	11
8. Board Configuration and Programming	12
9. Test Points	15
10. RGB LED Demonstration Design and Software GUI	17
11. GUI Serial Communication Interface	20
11.1. LED Control via SPI	20
11.2. SPI Protocol	20
11.3. Register Definitions	21
12. Ordering Information	23
Appendix A. Schematic Diagrams	24
Appendix B. Bill of Materials	30
References	33
Standards Documents	33
Technical Support Assistance	33
Revision History	34

Figures

Figure 2.1. iCE40 UltraPlus Breakout Board (Top Side)	6
Figure 5.1. Default Shunt Locations	9
Figure 8.1. Board Configuration for Programming Flash	12
Figure 8.2. Device Property Settings for Programming Flash	13
Figure 8.3. Setting Status in Diamond Programmer for Programming Flash	13
Figure 8.4. Device Property Settings for Programming iCE40 UltraPlus	14
Figure 9.1. J52 Header 'A' Breakouts	15
Figure 9.2. J2 Header 'B' Breakouts	15
Figure 9.3. J3 Header 'C' Breakouts	15
Figure 9.4. U6 PMOD Connector	16
Figure 9.5. J1 Adardvark Connector	16
Figure 9.6. Breakout Headers	16
Figure 10.1. SPI Flash Selection (Horizontal) for J6	17
Figure 10.2. iCE40 UltraPlus Selection (Vertical) for J6	18
Figure 10.3. iCE40 UltraPlus LED Demonstration Interface	18
Figure 11.1. SPI Physical Transaction	20
Figure A.1. Block Diagram	24
Figure A.2. FTDI Connection	25
Figure A.3. DUT Connection	26
Figure A.4. RGB, PMOD and HEADERS	27
Figure A.5. Regulator Connection	28
Figure A.6. SPI	29

Tables

Table 11.1. Register Address and Bit Field Allocation	20
Table 11.2. Bit Field Functionality Definition	20
Table 11.3. RGB Color Code Definition	21
Table 11.4. LED Brightness Code Definition	21
Table 11.5. Breathe Ramp Code Definition	22
Table 11.6. Blink Rate Code Definition	22

1. Introduction

Thank you for choosing the Lattice iCE40 UltraPlus™ Breakout Board.

This guide describes how to begin using the iCE40 UltraPlus Breakout Board, an easy-to-use platform for demonstrating the high-current LED drive capabilities of the iCE40 UltraPlus ; which has more memory to achieve functions mainly required in the customer mobile market. Along with the evaluation board and accessories, this kit includes a pre-loaded LED Driver Demo that demonstrates driving the RGB LEDs with a PWM circuit. In addition, most of the device's I/O pins are accessible via one of the several header locations on the board, facilitating rapid prototyping of user functions.

The contents of this user guide include demo operation, top-level functional descriptions of the various portions of the evaluation board, descriptions of the onboard connectors, shunts, and a complete set of schematics and the bill of materials for the iCE40 UltraPlus Breakout Board.

Note: Static electricity can severely shorten the lifespan of electronic components. Be careful when handling the iCE40 UltraPlus Breakout Board as to not damage it from ESD.

2. Features

The iCE40 UltraPlus Breakout Board includes:

- **iCE40 UltraPlus Breakout Board** – The iCE40 UltraPlus Breakout Board features the following on-board components and circuits:
 - iCE40 UltraPlus (iCE40UP5K-SG48) device in a 48-PIN QFN package.
 - Example of a board using this 0.5mm pitch QFN package.
 - High-current LED output
 - iCE40 UltraPlus Current Measurements
 - Standard USB cable for device programming.
 - RoHS-compliant packaging and process
- **Pre-loaded Demo** – The kit includes a pre-loaded demo to control the onboard RGB LED in conjunction with a software run GUI.
- **USB Connector Cable** – A mini B USB port provides power, a programming interface and communication for the software RGB LED GUI to the iCE40 UltraPlus SPI port.

Figure 2.1 shows the top side of the iCE40 UltraPlus Breakout Board indicating the specific features that are designed on the board.

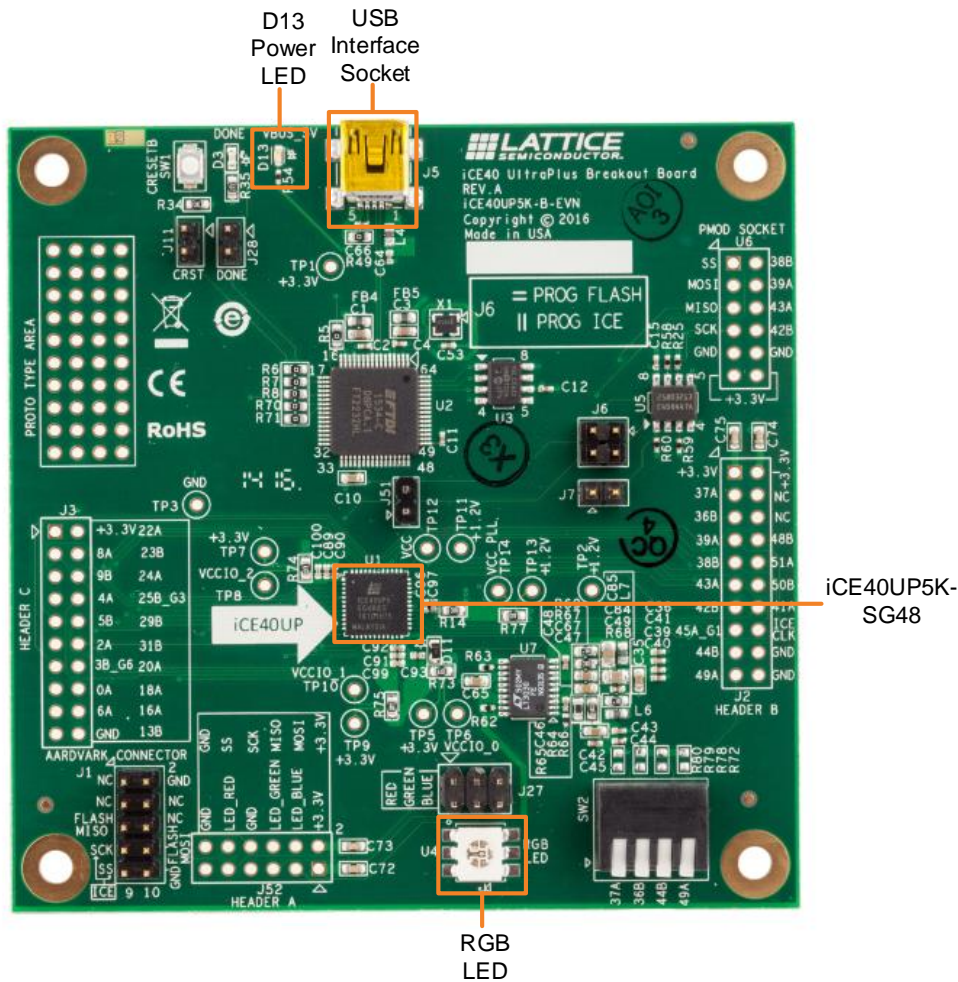

Figure 2.1. iCE40 UltraPlus Breakout Board (Top Side)

3. iCE40 UltraPlus Device

The board features an iCE40UP5K FPGA with a 1.2 V core supply. The device package is 48-PIN QFN. For a complete description of this device, see DS-1056, [iCE40 UltraPlus Family Data Sheet](#).

4. Software Requirements

You should install the following software before you begin developing designs for the board:

- Lattice iCEcube2 2017.01 (or higher)
- Diamond Programmer 3.9 (or higher)

These software are available at the Lattice website [Design Software & IP](#) page. Make sure you log in to www.latticesemi.com, otherwise these software downloads will not be visible. It is also recommended to download the RGB LED software GUI which interfaces with the iCE40 UltraPlus Breakout Board. This GUI allows you to control the RGB LED for color, brightness, blinking and breathing. Download the PC or MAC version of the GUI at www.latticesemi.com.

5. Demonstration Design Shunts

Lattice provides the RGB LED Driver Demo design programmed on the board. The RGB LED Driver Demo used in conjunction with the software GUI illustrates the use of a PWM driver controlling the LEDs on the board. Below is a description of the control jumpers for each LED.

- The RGB LED will transition colors
 - J27 can be used to probe RGB LED (Default shunted). If you remove J27, the RGB LED will not light up.

Figure 5.1 shows the default board shunt locations.

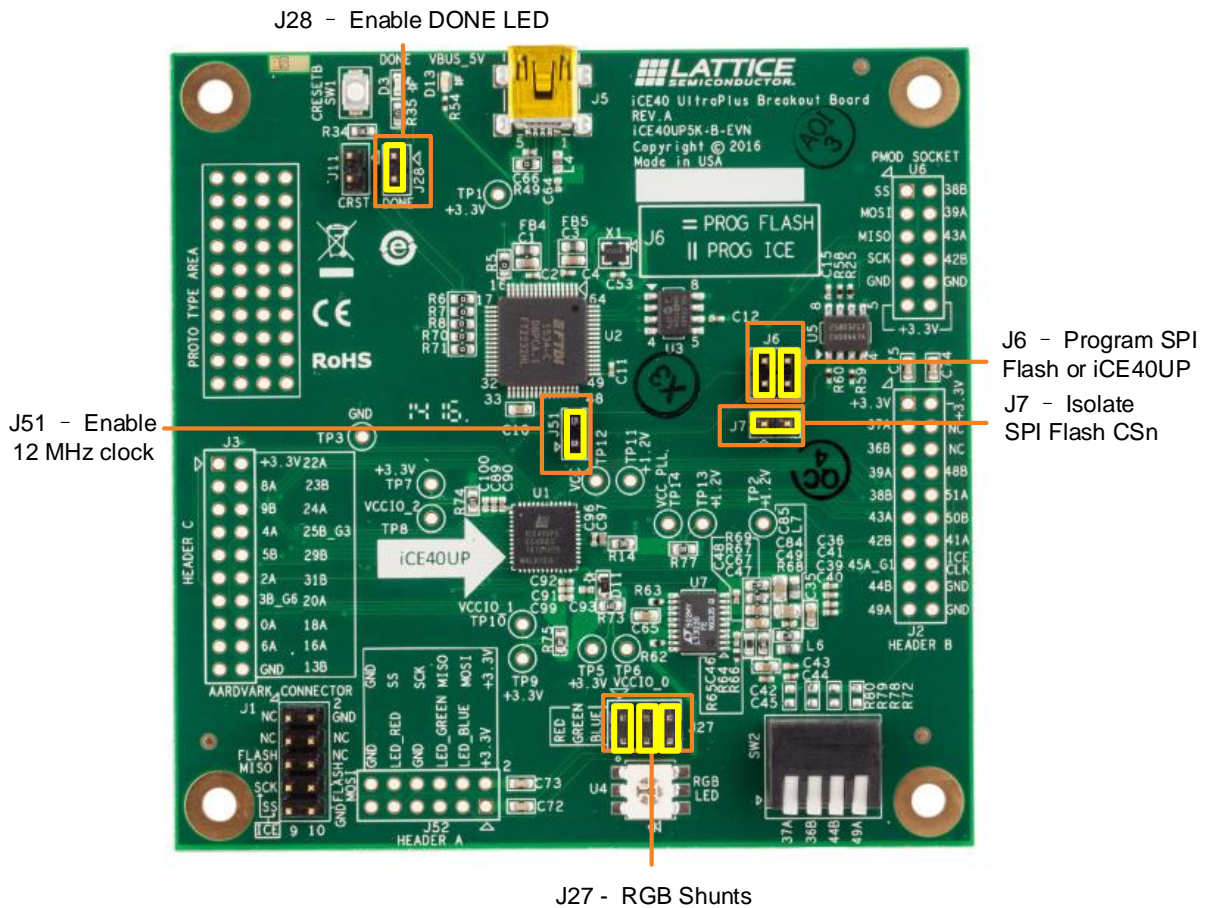

Figure 5.1. Default Shunt Locations

6. Clock Sources

The board has a single 12 MHz clock source. The 12 MHz clock drives both the FTDI USB interface device, and the iCE40UP5K device. The iCE40UP5K can be disconnected from the 12 MHz oscillator using J51. This is necessary, for example, when iCE40UP5K device pin35 is mistakenly programmed as an output and prevents the FTDI USB interface from operating.

7. Board Power

The board provides the following power features:

- Board Power
 - Board power is derived from the USB connection.
 - D13 Blue LED indicates Board Power
- iCE40 UltraPlus VCC/VCC_PLL
 - Onboard 1.2 V supply
 - ICC can be measured across the series resistor R76 (1 Ω) at TP11 and TP12
 - ICC_PLL can be measured across the series resistor R77 (1 Ω) at TP13 and TP14
- iCE40 UltraPlus VCCIO
 - Onboard 3.3 V supply
 - ICC0 can be measured across the series resistor R73 (1 Ω) at TP5 and TP6
 - ICC1 can be measured across the series resistor R75 (1 Ω) at TP9 and TP10
 - ICC2 can be measured across the series resistor R74 (1 Ω) at TP7 and TP8

The power supplies on the iCE40 UltraPlus Breakout Board are simplified and suitable for booting from the external SPI flash. The power supply sequencing does not conform to the NVCM boot requirements as specified in DS1056, [iCE40 UltraPlus Family Data Sheet](#). The user may encounter intermittent boot success and/or higher than specified startup currents when attempting to boot from NVCM.

8. Board Configuration and Programming

The board allows for programming of the iCE40 UltraPlus or the SPI Flash:

- SPI Flash Programming J6 shunt pins 1-3 and 2-4 (Default shunted)
 - U5 Micron Technology Inc. part number N25Q032A13ESC40F
- iCE40 UltraPlus Configuration or Programming J6 shunt pins 1-2 and 3-4
 - U1 iCE40UP5K – SG48
- CRESETB can be asserted by pushing SW1
 - Can be probed with J11
- Done LED D2
 - Can be probed with J28 (Default shunted)

Details of the iCE40 UltraPlus Board for SPI flash programming are shown in [Figure 8.1](#).

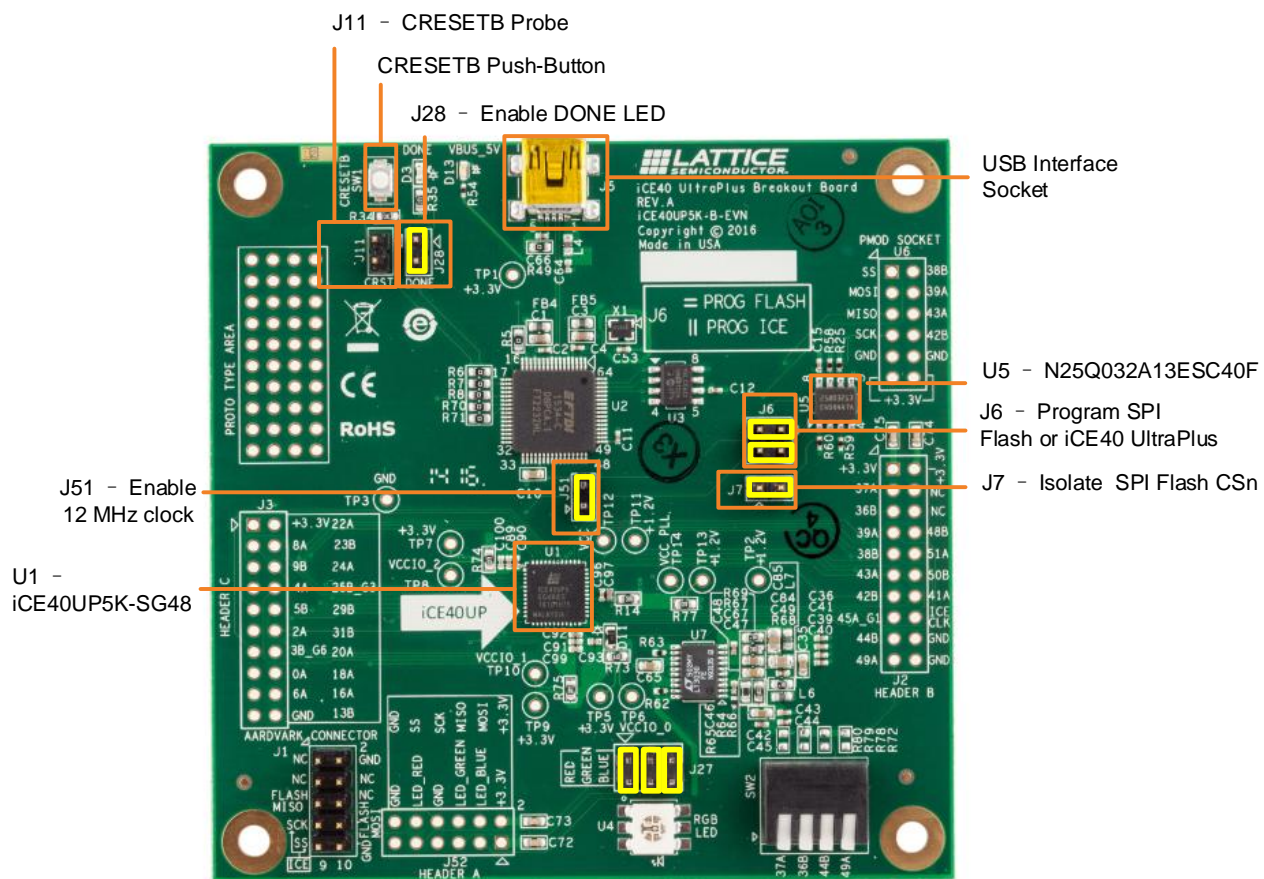

Figure 8.1. Board Configuration for Programming Flash

To program SPI flash in Diamond Programmer:

1. Make sure that the Standalone Diamond Programmer is installed.
2. Connect the iCE40 UltraPlus breakout board via the USB cable to a PC or MAC.
3. Start Diamond Programmer.
4. Set **Device Family** to “iCE40 UltraPlus” and **Device** to “iCE40UP5K”. Refer to [Figure 8.3](#).
5. Open the Device Properties dialog. Apply the settings highlighted in [Figure 8.2](#).
Programming file is the bitmap file that will be programmed into the iCE40 UltraPlus breakout board.

6. Click **OK** to exit Device Properties dialog.
7. Click the **Program** button in Diamond Programmer to download the bitstream file.

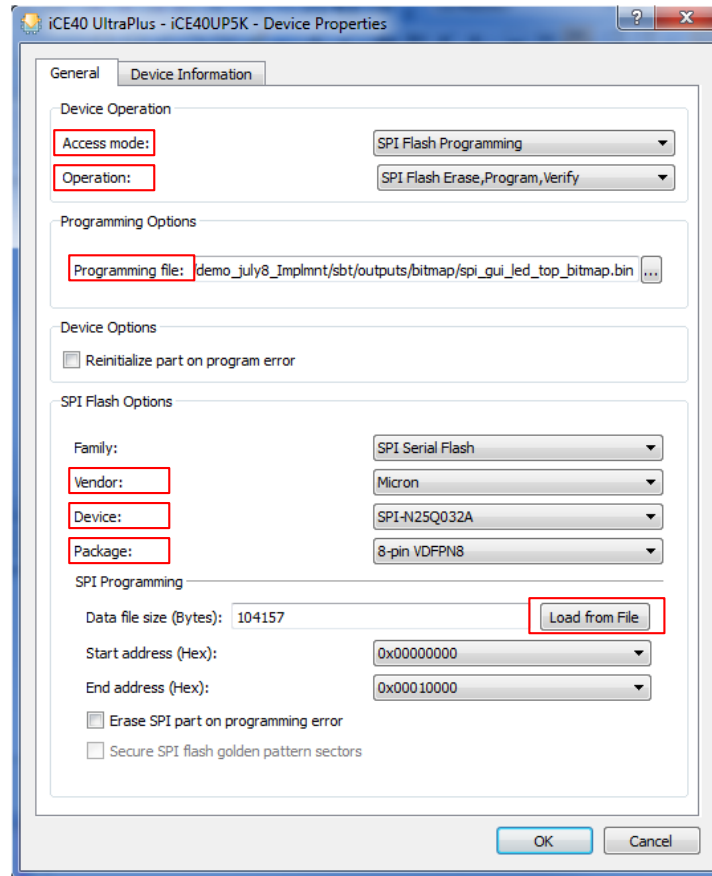

Figure 8.2. Device Property Settings for Programming Flash

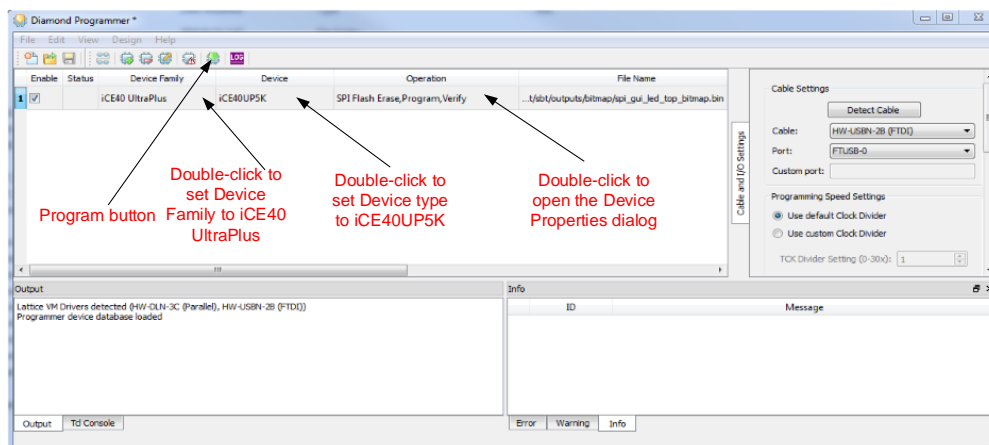

Figure 8.3. Setting Status in Diamond Programmer for Programming Flash

The differences between programming ICE40 UltraPlus and programming flash are described below.

To program ICE40 UltraPlus in Diamond Programmer:

1. Change jumpers on J6, shunt pins 1-2 and 3-4.
2. Apply the settings in the Device Properties dialog as shown in [Figure 8.4](#).

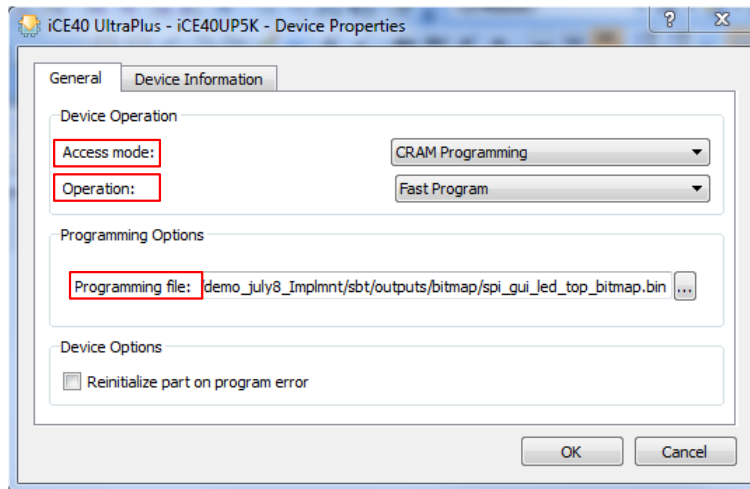

Figure 8.4. Device Property Settings for Programming iCE40 UltraPlus

For more information on Diamond Programmer, please refer to its user guide.

9. Test Points

The board features a number of headers and test connections which provide access to the iCE40 UltraPlus I/Os:

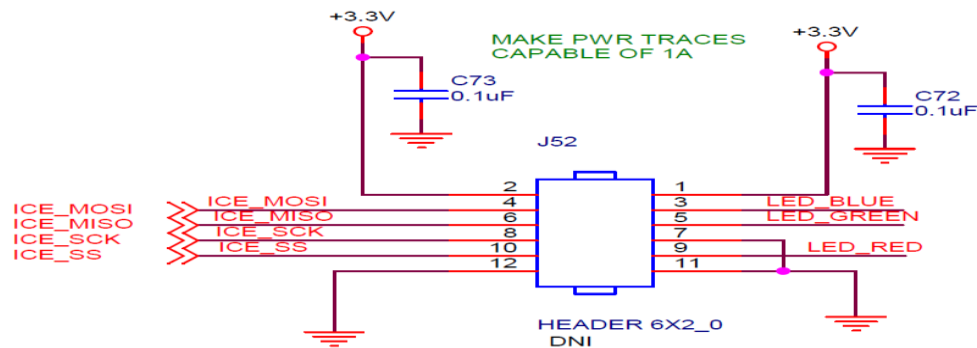

Figure 9.1. J52 Header 'A' Breakouts

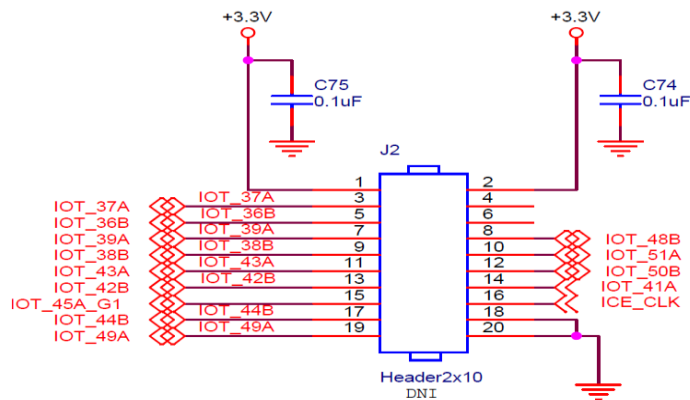

Figure 9.2. J2 Header 'B' Breakouts

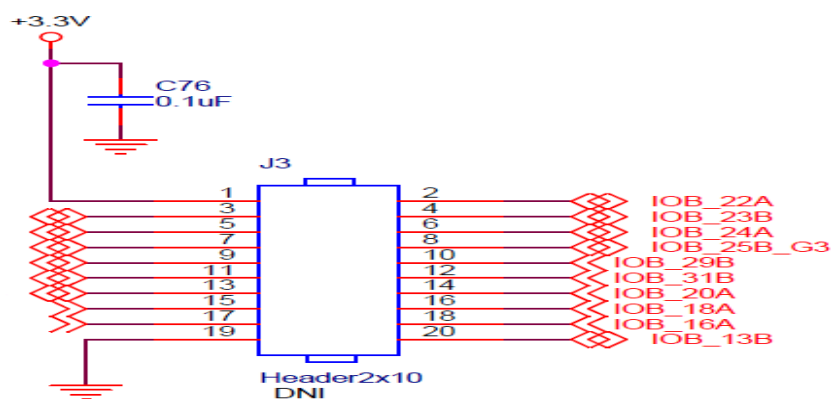

Figure 9.3. J3 Header 'C' Breakouts

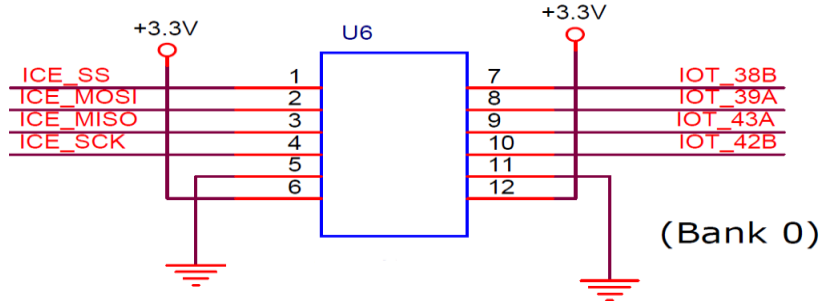

Figure 9.4. U6 PMOD Connector

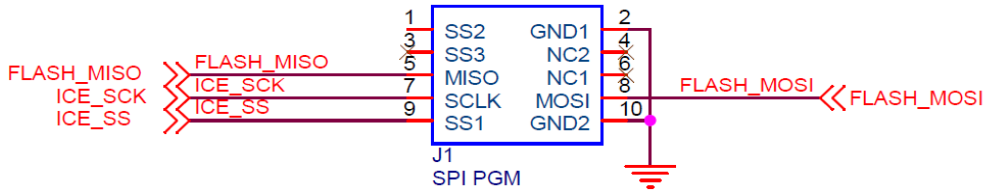

Figure 9.5. J1 Adardvark Connector

The break-out headers and test connectors are shown in Figure 9.6.

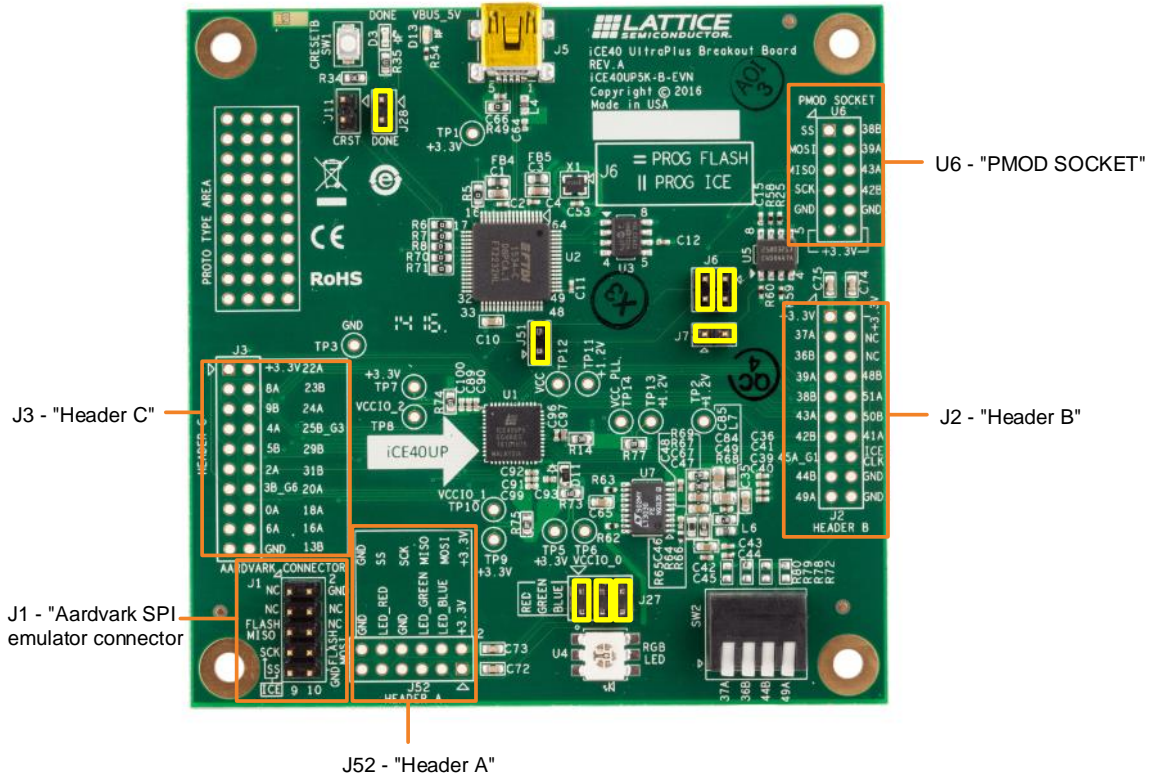

Figure 9.6. Breakout Headers

10. RGB LED Demonstration Design and Software GUI

The iCE40 UltraPlus Breakout Board can demonstrate a complete controller for an RGB LED. Following are the steps to run the demonstration. The Software GUI tool used here is the same as the one used with the iCE40 Ultra Breakout Board. You can refer to the Lattice website [iCE40 Ultra Breakout Board](#) page.

To run the demonstration:

1. Ensure that the RGB LED GUI is installed.
2. Make sure the jumpers on J6 are both in the horizontal position. This is the default pins 1-3 and 2-4 shorted together.

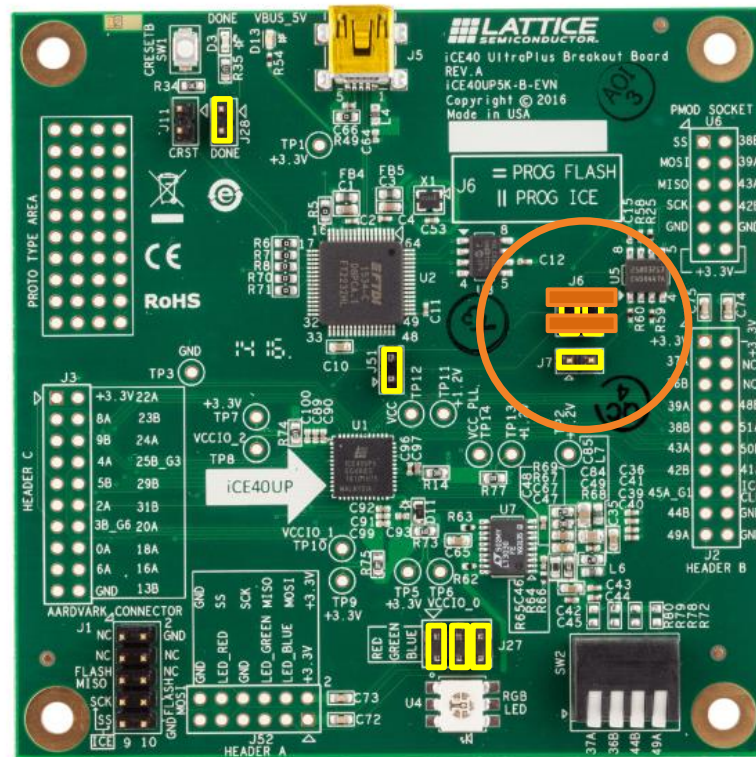

Figure 10.1. SPI Flash Selection (Horizontal) for J6

3. Connect the iCE40 UltraPlus breakout board via the USB cable to a PC or MAC.
4. After the iCE40 UltraPlus device has initialized and the RGB LED is illuminated RED, change the J6 jumper positions to vertical, shorting pins 1-2 and 3-4. This is required to allow the USB port to communicate with the iCE40UP5K device.

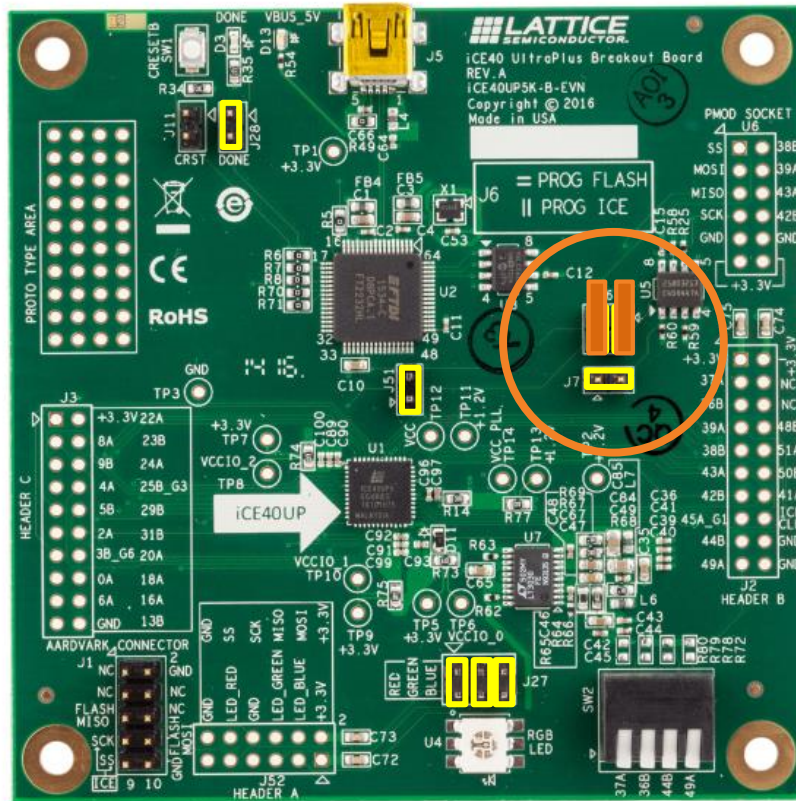

Figure 10.2. iCE40 UltraPlus Selection (Vertical) for J6

5. Start the RGB GUI on the PC or MAC.

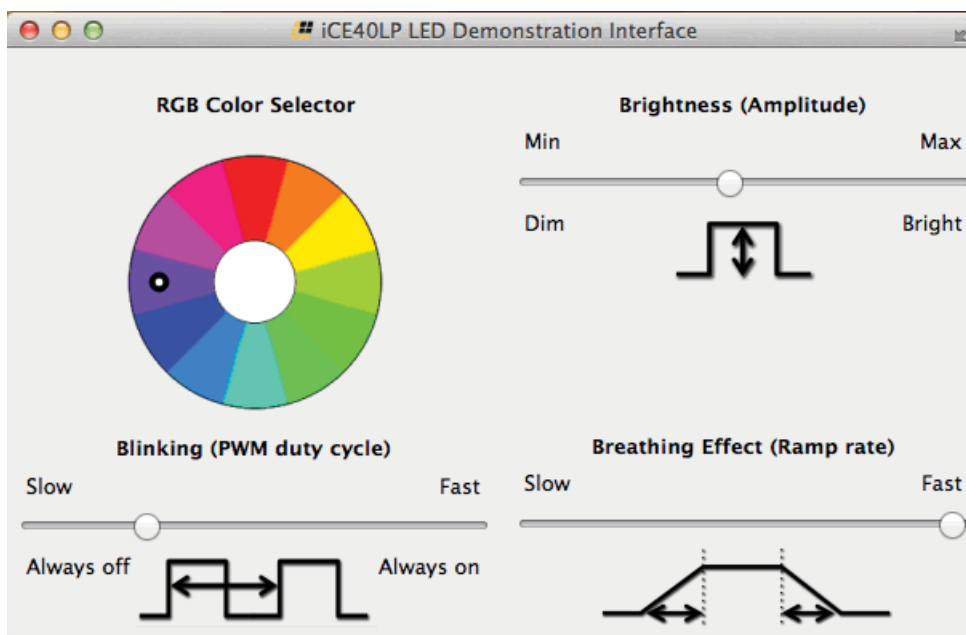

Figure 10.3. iCE40 UltraPlus LED Demonstration Interface

Now you can control the RGB LED on the iCE40 UltraPlus Breakout Board. You can set the color, brightness, blinking rate as well as breathing.

Note: The RGB GUI is the same demo tool used with iCE40 Ultra Breakout board.

11. GUI Serial Communication Interface

11.1. LED Control via SPI

The Software GUI demonstration program communicates with the iCE40 UltraPlus device using an SPI serial communication channel. The SPI interface (mode 0) control link is implemented using a simple write-only protocol (see Figure 11.1.)

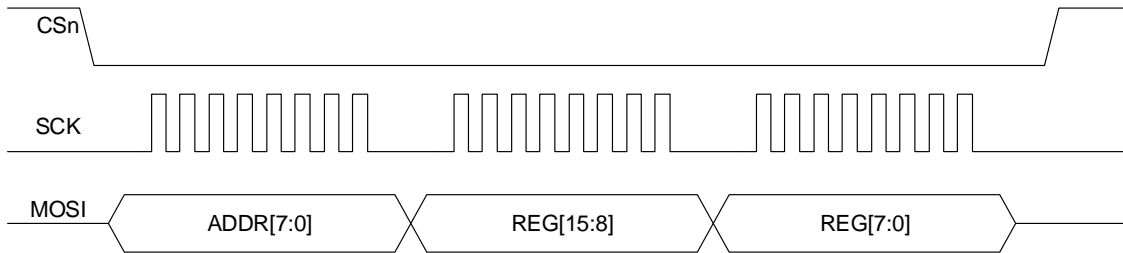

Figure 11.1. SPI Physical Transaction

11.2. SPI Protocol

Data on the MOSI serial line is transmitted MSB first.

Addr[7:0] – Controls which of the 16 bits are updated with REG data.

Note that Unspecified REG bits must be written, but are ignored.

Table 11.1. Register Address and Bit Field Allocation

Addr	Bits Written	Bit Position
0x13	REG[3:0]	-----dddd
0x14	REG[7:4]	-----cccc----
0x15	REG[11:8]	----bbbb-----
0x16	REG[15:12]	aaaa-----
0x19	REG[15:0]	aaaabbbbccccdddd

REG[15:0] – Consists of four control fields.

Table 11.2. Bit Field Functionality Definition

Field	Bit Positions	Function
aaaa	REG[15:12]	RGB Color[3:0]
bbbb	REG[11:8]	Brightness[3:0]
cccc	REG[7:4]	Breathe Ramp [3:0]
dddd	REG[3:0]	Blink Rate [3:0]

11.3. Register Definitions

Table 11.3. RGB Color Code Definition

Default setting (hardware, software) is denoted by (*).

RGB Color[3:0]	Color	Color Code
0000*	Red	#FF0000
0001	Orange	#FF7F00
0010	Yellow	#FFFF00
0011	Chartreuse	#7FFF00
0100	Green	#00FF00
0101	Spring Green	#00FF7F
0110	Cyan	#00FFFF
0111	Azure	#007FFF
1000	Blue	#0000FF
1001	Violet	#7F00FF
1010	Magenta	#FF00FF
1011	Rose	#FF007F
1100	—	—
1101	—	—
1110	—	—
1111	White	#FFFFFF

Table 11.4. LED Brightness Code Definition

Brightness[3:0]	Level (%)
0000	6.25 (dim)
0001	12.5
0010	18.78
0011	25
0100	31.25
0101	37.5
0110	43.75
0111*	50
1000	56.25
1001	62.5
1010	68.75
1011	75
1100	81.25
1101	87.5
1110	93.75
1111	100 (bright)

Table 11.5. Breathe Ramp Code Definition

Breathe Ramp[3:0]	Level (%)
0000*	.0x (fast)
0001	.063x
0010	.125x
0011	.25x
0100	.5x
0101	1x
0110	2x
0111	4x (slow)
1000	—
1001	—
1010	—
1011	—
1100	—
1101	—
1110	—
1111	—

Table 11.6. Blink Rate Code Definition

Blink Rate[3:0]	Level (%)
0000	Always On
0001	1/16 (fast)
0010	1/8
0011	1/4
0100	1/2
0101*	1
0110	2
0111	4
1000	Always Off
1001	—
1010	—
1011	—
1100	—
1101	—
1110	—
1111	—

12. Ordering Information

Description	Ordering Part Number	China RoHS Environment- Friendly Use Period (EFUP)
iCE40 UltraPlus Breakout Board	iCE40UP5K-B-EVN	

Appendix A. Schematic Diagrams

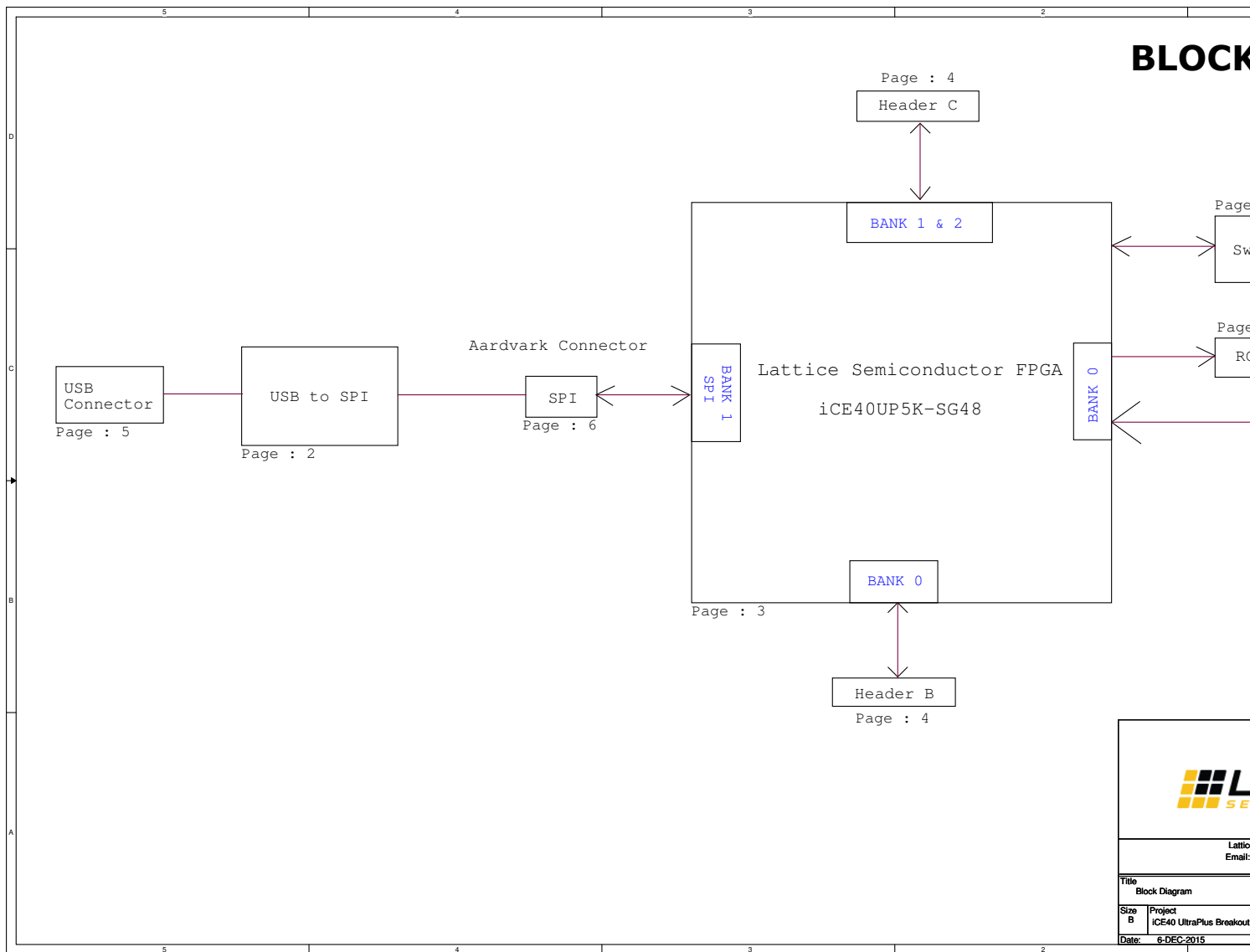

Figure A.1. Block Diagram

FTDI COM

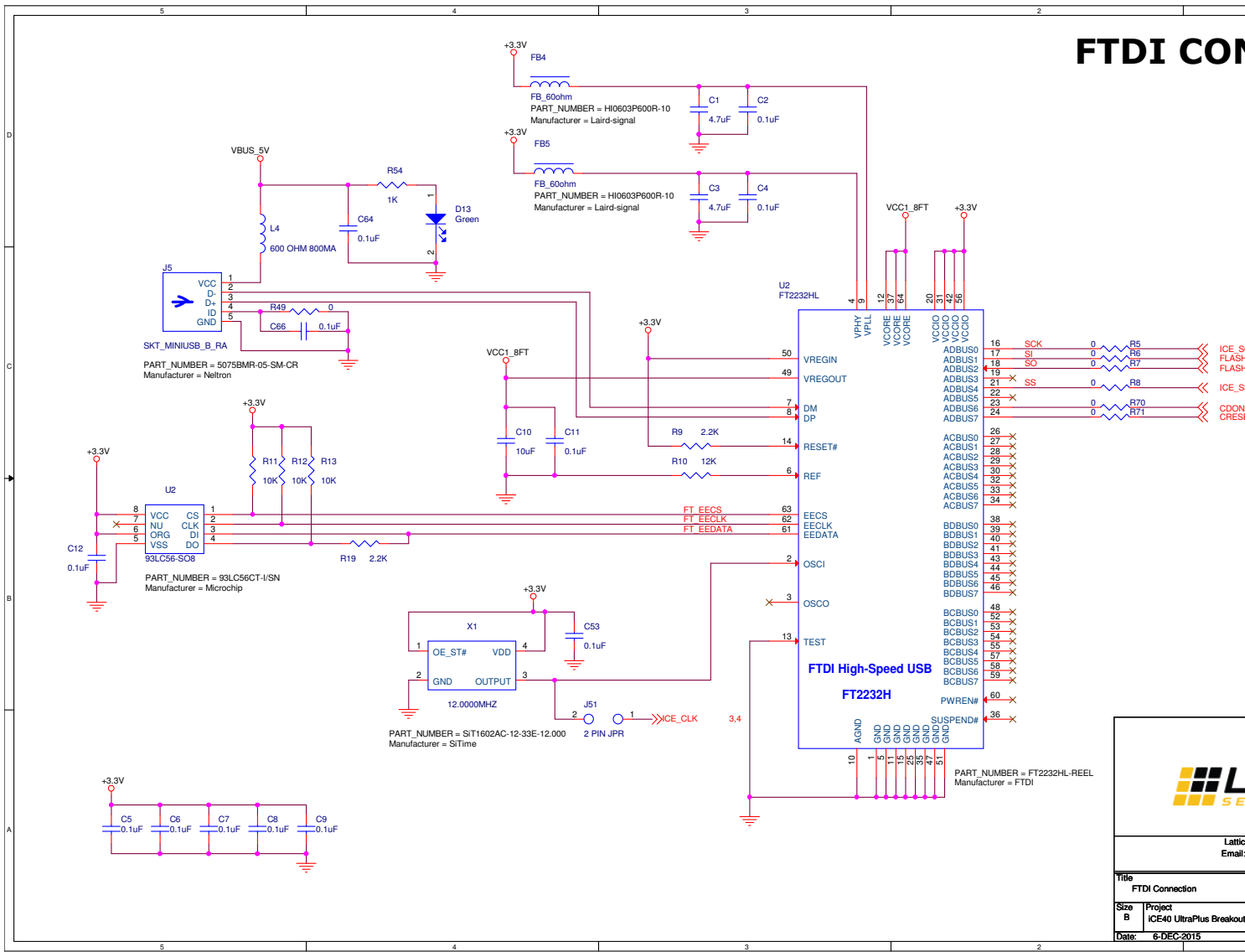

Figure A.2. FTDI Connection

ICE40 UltraPlus Breakout Board
User Guide

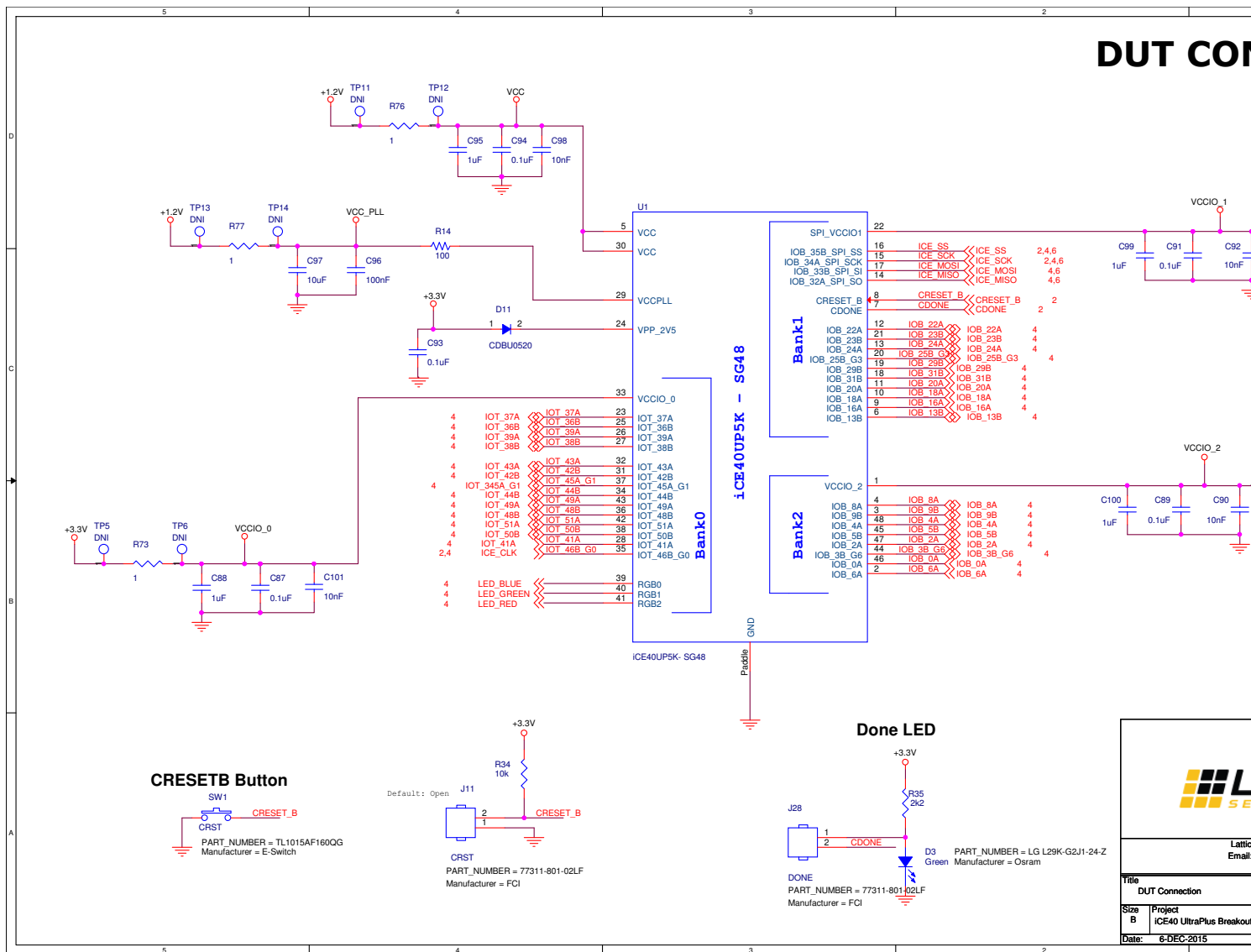

Figure A.3. DUT Connection

RGB, PMOD and HEADERS

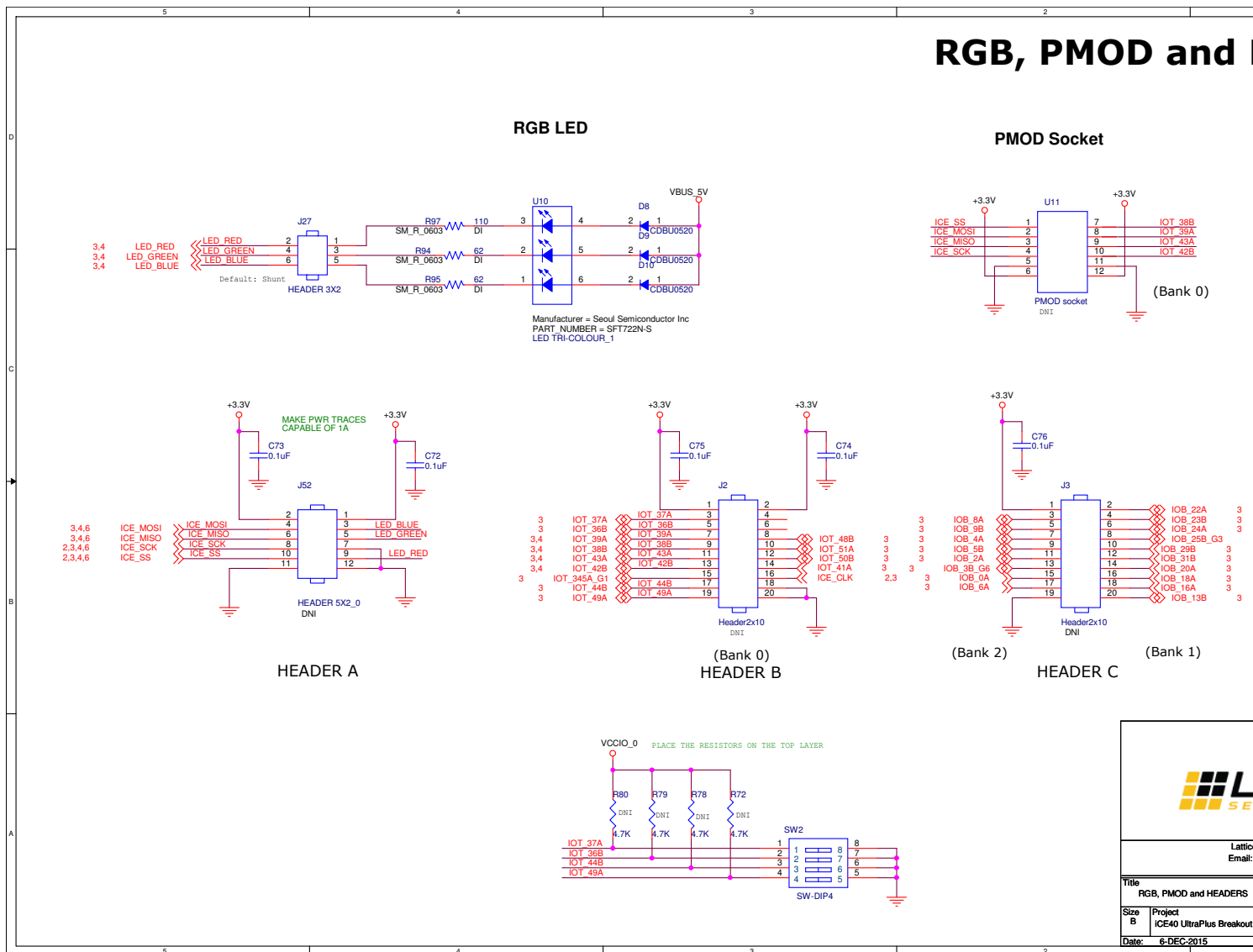

Figure A.4. RGB, PMOD and HEADERS

REGULATOR CONNECTION

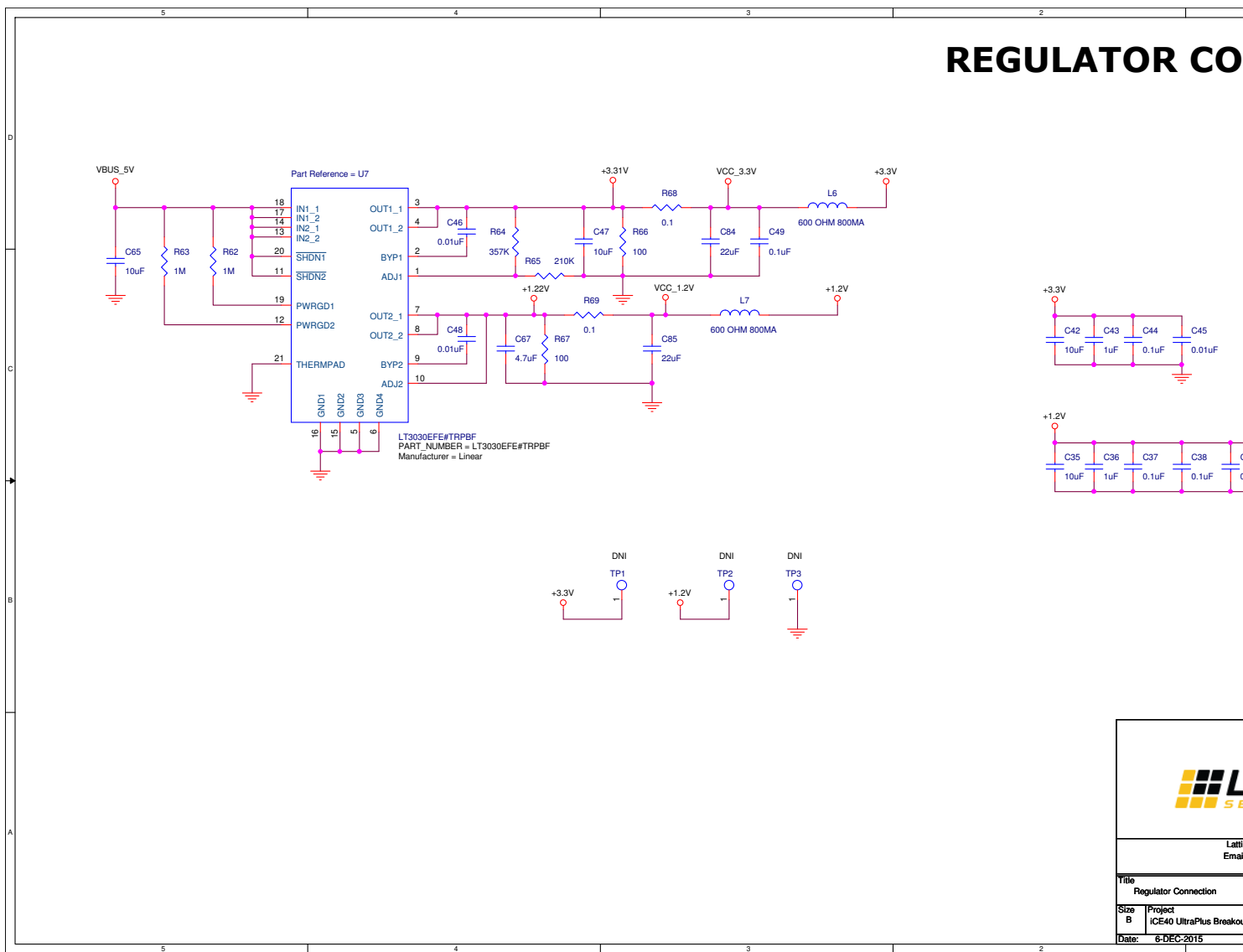

Figure A.5. Regulator Connection

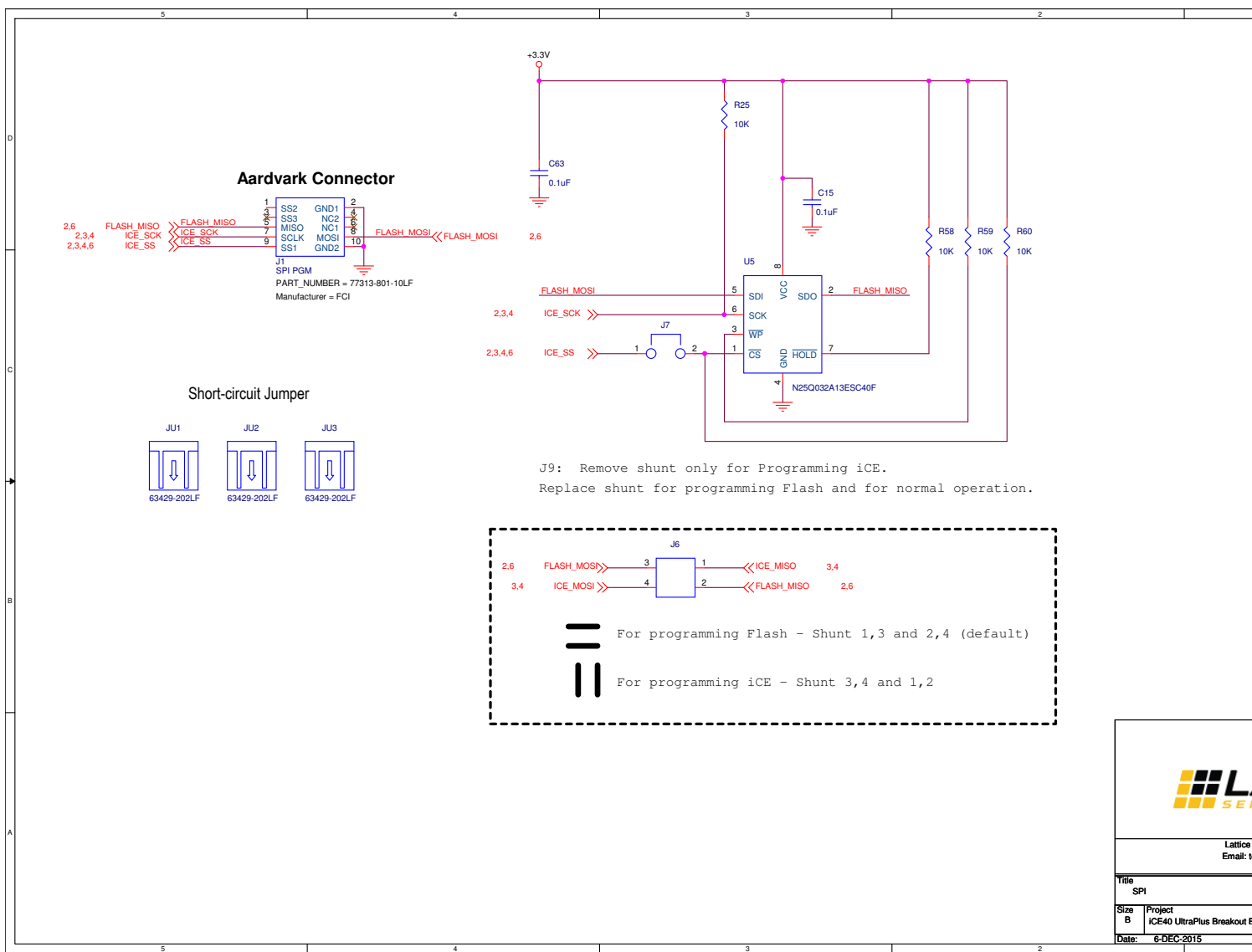

Figure A.6. SPI

L
SEMICONDUCTOR

Lattice
Email: t

Title
SPI

Size
B Project
ICE40 UltraPlus Breakout E

Date: 6-DEC-2015

Appendix B. Bill of Materials

Item	Reference	Qty	Part	PCB Footprint	PART_NUMBER	Manufacturer	DESCRIPTION
1	C1,C3,C67	3	4.7uF	cc0603	ECJ-1VB0J475K	Panasonic	CAP CER 4.7UF 6.3V 10% X5R 0603
2	C2,C4,C5,C6,C7, C8,C9,C11,C12, C15,C37,C38,C39, C40,C44,C49,C53, C63,C64,C66,C87, C89,C91,C93,C94	25	0.1uF	cc0402	C0402C104K4RA CTU	Kemet	CAP CER 0.1UF 16V 10% X7R 0402
3	C10,C35,C42,C47, C65	5	10uF	cc0603	LMK107BJ106M ALTD	Taiyo Yuden	CAP CER 10UF 10V 20% X5R 0603
4	C36,C43	2	1uF	cc0402	C0402C105K9PA CTU	Kemet	CAP CER 1UF 6.3V 10% X5R 0402
5	C41,C45,C46,C48	4	0.01uF	cc0402	C0402C103J4RA CTU	Kemet	CAP CER 10000PF 16V 5% X7R 0402
6	C72,C73,C74,C75, C76	5	0.1uF	cc0603	C0603C104K4RA CTU	Kemet	CAP CER 0.1UF 16V 10% X7R 0603
7	C84,C85	2	22uF	cc0805	LMK212BJ226M G-T	Taiyo Yuden	CAP CER 22UF 10V 20% X5R 0805
8	C88, C95, C99, C100	4	1uF	cc0402	C0402C105K4PA C7867	Kemet	CAP CER 1UF 16V 10% X5R 0402
9	C90, C92, C98, C101	4	10nF	cc0402	C0402C103J4RA CTU	Kemet	CAP CER 10000PF 16V 5% X7R 0402
10	C96	1	100nF	cc0402	C0402C104K4RA CTU	Kemet	CAP CER 0.1UF 16V 10% X7R 0402
11	C97	1	10uF	cc0402	CL05A106MP5N UNC	Samsung	CAP CER 10UF 10V X5R 0402
12	D3	1	Green	SM_D_0603	LG L29K-G2J1- 24-Z	Osram	LED SMARTLED GREEN 570NM 0603
13	D8,D9,D10,D11	4	CDBU0130R	diode_sod523f	CDBU0130R	Comchip	DIODE SCHOTTKY 30V 100MA 0603
14	D13	1	Blue	led_0603	LTST-C190TBKT	LITE-On Inc.	LED BLUE CLEAR 0603 SMD
15	FB4,FB5	2	FB_60ohm	L0603	HI0603P600R-10	Laird-signal	FERRITE CHIP POWER 60 Ω SMD
16	J1	1	SPI PGM	hdr5x2	77313-801-10LF	FCI	CONN HEADER .100 DUAL STR 10POS
17	J2,J3	2	Header2x10	hdr_samtec_mts w_2x10_100	MTSW-110-08-T- D-300	Samtec	CONN HEADER 20POS .100" TH DUAL
18	J5	1	SKT_MINIUSB_ B_RA	skt_miniusb_b_r a	5075BMR-05- SM-CR	Neltron	CONN MINI USB RCPT RA TYPE B SMD
19	J6	1	TSW-102-07-F- D	hdr_samtec_tsw _2x2_100	TSW-102-07-F-D	Samtec	CONN HEADER 4POS .100" DBL
20	J7	1	TSW-102-07-G- S	hdr_samtec_tsw _1x2_100	TSW-102-07-G-S	Samtec	CONN HEADER 2POS .100" SGL GOLD
21	J11	1	CRST	HDR1X2-40	77311-801-02LF	FCI	CONN HEADER

Item	Reference	Qty	Part	PCB Footprint	PART_NUMBER	Manufacturer	DESCRIPTION
							.100 SINGL STR 2POS
22	J27	1	HEADER 3X2	HDR3x2	—	—	—
23	J28	1	DONE	HDR1X2-40	77311-801-02LF	FCI	CONN HEADER .100 SINGL STR 2POS
24	J51	1	2 PIN JPR	2PIN_100MIL	—	—	—
25	J52	1	HEADER 6X2_0	HDR_6X2	—	—	—
26	L4,L6,L7	3	600 OHM 800MA	fb0603	BLM18HE601SN 1D	Murata	FERRITE CHIP 600 Ω 800MA 0603
27	R5,R6,R7,R8,R49, R70,R71	7	0	cr0603	RC0603JR-070RL	Yageo	RES 0.0 Ω 1/10W JUMP 0603 SMD
28	R9,R19	2	2.2K	cr0402	RC0402FR- 072K2L	Yageo	RES 2.20 K Ω 1/16W 1% 0402 SMD
29	R10	1	12K	cr0402	RC0402FR- 0712KL	Yageo	RES 12.0 K Ω 1/16W 1% 0402 SMD
30	R11,R12,R13,R25, R58,R59,R60	7	10K	cr0402	RC0402FR- 0710KL	Yageo	RES 10.0 K Ω 1/16W 1% 0402 SMD
31	R14	1	100	R0603	CRCW0603100R FKEAHP	Vishay	RES 100 Ω 0.25W 1% 0603 SMD
32	R34	1	10k	R0603	ERJ-3EKF1002V	Panasonic	RES 10 K Ω 1/10W 1% 0603 SMD
33	R35	1	2k2	R0603	ERJ-3EKF2201V	Panasonic	RES 2.2 K Ω 1/10W 1% 0603 SMD
34	R54	1	1K	cr0402	ERJ-2GEJ102X	Panasonic	RES SMD 1 K Ω 5% 1/10W 0402
35	R62,R63	2	1M	cr0402	RC0402JR- 071ML	Yageo	RES 1.0M Ω 1/16W 5% 0402 SMD
36	R64	1	357K	cr0603	ERJ-3EKF3573V	Panasonic	RES SMD 357 K Ω 1% 1/10W 0603
37	R65	1	210K	cr0402	ERJ-2RKF2103X	Panasonic	RES SMD 210 K Ω 1% 1/10W 0402
38	R66,R67	2	100	cr0603	RC0603FR- 07100RL	Yageo	RES 100 Ω 1/10W 1% 0603 SMD
39	R68,R69	2	0.1	cr0603	ERJ-3RSFR10V	Panasonic	RES .10 Ω 1/10W 1% 0603 SMD
40	R72,R78,R79,R80	4	4.7K	cr0603	CRCW06034K70 FKEA	Vishay	RES 4.70 K Ω 1/10W 1% 0603 SMD
41	R73,R74,R75,R76, R77	5	1	cr0603	RC0603FR-071RL	Yageo	RES SMD 1 Ω 1% 1/10W 0603
42	R94,R95	2	62	SM_R_0603	ERJ-3EKF62R0V	Panasonic	RES 62 Ω 1/10W 1% 0603 SMD
43	R97	1	110	SM_R_0603	ERJ-3EKF1100V	Panasonic	RES 110 Ω 1/10W 1% 0603 SMD
44	SW1	1	CRST	2psmd_eswitch	TL1015AF160QG	E-Switch	SWITCH TACTILE SPST-NO 0.05 A 12V
45	SW2	1	SW-DIP4	sw_sp_st_cts_19	195-4MST	CTS	SWITCH SIDE

Item	Reference	Qty	Part	PCB Footprint	PART_NUMBER	Manufacturer	DESCRIPTION
				5-4mst		Electrocomponents	ACTUATED 4 SEC 50V
46	TP1,TP2,TP3	3	TP_S_40_63	tp_s_40_63	—	—	Square test point, 40mil inner diameter, 63mil outer diameter
47	TP5,TP6,TP7,TP8, TP9,TP10,TP11,TP12,TP13,TP14	10	DNI	tp_s_40_63	—	—	Square test point, 40mil inner diameter, 63mil outer diameter
48	U1	1	iCE40UP5K/3K-SG48	iCE40UP5K_SG48	—	—	—
49	U2	1	FT2232HL	tqfp64_0p5_12p2x12p2_h1p6	FT2232HL-REEL	FTDI	IC USB HS DUAL UART/FIFO 64-LQFP
50	U3	1	93LC56-SO8	so8_50_244	93LC56CT-I/SN	Microchip	IC EEPROM 2KBIT 3MHZ 8SOIC
51	U4	1	LED TRI-COLOUR_1	6-PLCC	SFT722N-S	Seoul Semiconductor Inc.	LED RED/GRN/BLU CLEAR LENS 6PLCC
52	U5	1	N25Q032A13ESC40F	so8_50_244	N25Q032A13ESC40F	Micron	IC Flash Mem Serial-SPI 3V/3.3V 32M-Bit 4M 7ns 8-Pin SO T/R
53	U6	1	PMOD socket	HDR_2X6	—	—	—
54	U7	1	LT3030EFE#TRPBF	tssop20_26_260_thrm_pad	LT3030EFE#TRPBF	Linear	IC REG LDO ADJ 20TSSOP
55	X1	1	12.0000MHZ	2_5mmx2mm	SiT1602AC-12-33E-12.000	SiTime	OSC MEMS 12MHZ H/LV-CMOS SMD
57	iCE40 ULTRAPLUS BREAKOUT BOARD PCB	1	—	—	305-PD-16-0084	PACTRON	—

References

Standards Documents

The standards used in this document and their abbreviations are listed on the table below.

Abbreviation	Standards Publication, Organization, and Date
HDMI	<i>High Definition Multimedia Interface</i> , Revision 1.4a, HDMI Licensing LLC., March 2010
HCTS	<i>HDMI Compliance Test Specification</i> , Revision 1.4a, HDMI Licensing LLC., March 2010
HDCP	<i>High-bandwidth Digital Content Protection</i> , Revision 2.2, Digital Content Protection, LLC; February 2013 <i>High-bandwidth Digital Content Protection</i> , Revision 1.4, Digital Content Protection, LLC; July 2009
DVI	<i>Digital Visual Interface</i> , Revision 1.0, Digital Display Working Group, April 1999
E-EDID	<i>Enhanced Extended Display Identification Data Standard</i> , Release A Revision 1, VESA; February 2000
CEA-861-D	<i>A DTV Profile For Uncompressed High Speed Digital Interfaces</i> , EIA/CEA, July 2006
EDDC	<i>Enhanced Display Data Channel Standard</i> , Version 1, VESA, September 1999
MHL	<i>MHL (Mobile High-definition Link) Specification</i> , Version 3.0, MHL, LLC, August 2013

For more information on the specifications that are applied in this document, contact the responsible standards groups listed on the table below.

Standards Group	Web URL
ANSI/EIA/CEA	http://global.ihs.com
VESA	http://www.vesa.org
HDCP	http://www.digital-cp.com
DVI	http://www.ddwg.org
HDMI	http://www.hdmi.org
MHL	http://www.mhlconsortium.org

Technical Support Assistance

For assistance, submit a technical support case at www.latticesemi.com/techsupport.

Email: techsupport@latticesemi.com

Revision History

Date	Version	Change Summary
March 2017	1.1	<ul style="list-style-type: none">— Corrected document status; removed “Preliminary”.— iCE40 UltraPlus Family Data Sheet document number changed to DS1056.— Update Lattice iCEcube2 to version 2017.01.— Updated Diamond Programmer version to 3.9.— Updated Appendix A. Schematic Diagrams.— Removed Lattice Semiconductor Documents section.
September 2016	1.0	Initial release.



7th Floor, 111 SW 5th Avenue
Portland, OR 97204, USA
T 503.268.8000
www.latticesemi.com

X-ON Electronics

Largest Supplier of Electrical and Electronic Components

Click to view similar products for [Programmable Logic IC Development Tools](#) category:

Click to view products by [Lattice](#) manufacturer:

Other Similar products are found below :

[HLDC-DDR3-A](#) [DK-DEV-5SGXEA7N](#) [EK-10M50F484](#) [EPXA4F672C2](#) [EPXA4F672C3](#) [EPXA4F672C1](#) [P0435](#) [K0161](#) [LCMXO256C-S-EVN](#) [12GSDIFMCCD](#) [SFP+X4FMCCD](#) [88980182](#) [P0582](#) [HW-PWAC-2600317](#) [DEV-17514](#) [LCMXO3D-9400HC-B-EVN](#) [P0671](#) [DK-K7-CONN-G](#) [P0467](#) [LCMXO2-1200ZE-P1-EVN](#) [LCMXO2-4000HE-DSIB-EVN](#) [DK-DEV-4SGX530N](#) [LCMXO3L-SMA-EVN](#) [P006-006-2](#) [EK-U1-VCU108-G](#) [A2F500-DEV-KIT-2](#) [LCMXO3LF-9400C-ASC-B-EVN](#) [471-014](#) [EVAL-TPG-ZYNQ3](#) [SL001](#) [80-001005](#) [P0466-EDU](#) [EK-10CL025U256](#) [P0496](#) [P0493](#) [DK-SOC-10AS066S-A](#) [DK-DEV-10CX220-A](#) [80-001002](#) [iCE40UP5K-MDP-EVN](#) [RXCA10S066PF34-IDK00A](#) [ALTSODIAC5ST](#) [ALTHYDRAC5GX](#) [ALTNITROC5GX](#) [ALTBERYLLC5GX](#) [471-015](#) [LFE3-17EA-USB3-EVN](#) [1553](#) [4332](#) [HinjKit](#)