



# ECP5™ Evaluation Board

## User Guide

FPGA-EB-02017-1.0

July 2018

## Contents

Acronyms in This Document .....	5
1. Introduction .....	6
1.1. ECP5 Evaluation Board .....	6
1.2. Features .....	8
1.3. ECP5 Device .....	8
2. Applying Power to the Board .....	9
3. Programming and I <sup>2</sup> C .....	10
3.1. JTAG Download Interface .....	10
3.2. Alternate JTAG Download Interface .....	10
3.3. JTAG to MSPI Pass-through Interface .....	11
3.4. Other JTAG Configuration Pins .....	11
3.5. Configuration Modes .....	11
4. ECP5 Clock Sources .....	12
5. Headers and Test Connections .....	13
5.1. Versa Headers .....	13
5.2. Arduino Board GPIO Headers .....	15
5.3. Raspberry Pi Board GPIO Header .....	17
5.4. GPIO Headers .....	18
5.5. Microphone Expansion Header .....	21
5.6. PMOD Header .....	21
5.7. JTAG Header .....	22
5.8. Parallel Configuration Header .....	22
6. Control Buses - I <sup>2</sup> C, I <sup>3</sup> C, UART, and SPI .....	23
6.1. I <sup>2</sup> C and I <sup>3</sup> C Topology .....	23
6.2. UART Topology .....	24
6.3. SPI Topology .....	24
6.3.1. SPI Configuration .....	24
6.3.2. SPI Flash Access .....	25
7. LEDs and Switches .....	26
7.1. DIP Switch .....	26
7.2. Configuration Mode Switch .....	26
7.3. General Purpose Push Buttons .....	26
7.4. General Purpose LEDs .....	27
7.5. Indicator LEDs .....	27
8. Software Requirements .....	28
9. Storage and Handling .....	28
10. Ordering Information .....	28
References .....	29
Lattice Semiconductor Documents .....	29
Technical Support Assistance .....	30
Appendix A. ECP5 Evaluation Board Schematics .....	31
Appendix B. ECP5 Evaluation Board Bill of Materials .....	43
Revision History .....	49

## Figures

Figure 1.1. Top View of ECP5 Evaluation Board.....	6
Figure 1.2. Bottom View of ECP5 Evaluation Board .....	7
Figure 1.3. Top View of ECP5 Evaluation Board – Jumper Locations.....	7
Figure 2.1. Board Power Supply.....	9
Figure 3.1. Configuration and I <sup>2</sup> C Architecture.....	10
Figure 6.1. I <sup>2</sup> C Architecture, I <sup>3</sup> C, and UART Options .....	24
Figure 6.2. SPI Interface.....	25
Figure A. 1. Title Page .....	31
Figure A. 2. Block Diagram.....	32
Figure A. 3. USB Interface .....	33
Figure A. 4 Arduino Header (BANK2) .....	34
Figure A. 5. Raspberry Pi Header (BANK3).....	35
Figure A. 6. SERDES SMA .....	36
Figure A. 7. IO Breakout (BANK0, BANK1, BANK6) .....	37
Figure A. 8. IO Breakout (BANK7, Differential Pairs) .....	38
Figure A. 9. Configuration .....	39
Figure A. 10. Power Decoupling and LEDs .....	40
Figure A. 11. Power Hookup.....	41
Figure A. 12. Power Regulators .....	42

## Tables

Table 2.1. ECP5 VCCIO Supply Options .....	9
Table 3.1. JTAG Connections .....	10
Table 3.2. Other JTAG Signals .....	11
Table 3.3. CFGMDN Mode Settings .....	11
Table 4.1. Clock Sources .....	12
Table 5.1. Versa J39 Header Pin Connections.....	13
Table 5.2. Versa J40 Header Pin Connections.....	14
Table 5.3. Arduino J6 Pin Connections .....	15
Table 5.4. Arduino J3 Pin Connections .....	15
Table 5.5. Arduino J7 Pin Connections .....	16
Table 5.6. Arduino J4 Pin Connections .....	16
Table 5.7. Raspberry Pi JP8 Header Pin Connections .....	17
Table 5.8. J5 Header Pin Connections.....	18
Table 5.9. J8 Header Pin Connections.....	19
Table 5.10. J32 Header Pin Connections .....	19
Table 5.11. J33 Header Pin Connections .....	20
Table 5.12. J30 Header Pin Connections .....	21
Table 5.13. J31 Header Pin Connections .....	21
Table 5.14. J1 Header Pin Connections.....	22
Table 5.15. J38 Header Pin Connections .....	22
Table 6.1. I <sup>2</sup> C Global Bus Connections .....	23
Table 6.2. ECP5 SPI Connections.....	25
Table 7.1. Eight-Position DIP Switch Signals .....	26
Table 7.2. CFGMDN Switch Signals .....	26
Table 7.3. Push Button Switch Signals .....	26
Table 7.4. General Purpose LED Signals.....	27

---

Table 7.5. Various LED Signals .....	27
Table 10.1. Ordering Information .....	28

## Acronyms in This Document

A list of acronyms used in this document.

Acronym	Definition
ASC	Analog Sense and Control
caBGA	Chip Array Ball Grid Array
CMOS	Complementary Metal-Oxide Semiconductor
DIP	Dual Inline Package
DNI	Do Not Install
ESD	Electro Static Discharge
FPGA	Field Programmable Logic Array
FTDI	Future Technology Devices International
GDDR	Graphics Double Data Rate
GPIO	General Purpose Input/Output
I <sup>2</sup> C	Inter-Integrated Circuit
I <sup>3</sup> C	Improved Inter-Integrated Circuit
JTAG	Joint Test Action Group
LVDS	Low-Voltage Differential Signaling
MDP	Mobile Development Platform
PMOD	Peripheral Module
SCM	Serial Configuration Mode
SPCM	Slave Parallel Configuration Mode
SPI	Serial Peripheral Interface
UART	Universal Asynchronous Receiver Transmitter
USB	Universal Serial Bus

# 1. Introduction

The Lattice Semiconductor ECP5™ Evaluation Board allows designers to investigate and experiment with the features of the ECP5-5G Field Programmable Gate Array (FPGA). The features of the ECP5 Evaluation Board can assist engineers with the rapid prototyping and testing of their specific designs.

The ECP5 Evaluation Board is part of the ECP5 Evaluation Kit, which includes the following:

- ECP5 Evaluation Board pre-loaded with the demo design
- Mini USB cable
- Quick Start Guide

The contents of this user guide include top-level functional descriptions of the various portions of the development board, descriptions of the on-board headers, diodes and switches and a complete set of schematics.

## 1.1. ECP5 Evaluation Board

The ECP5 Evaluation Board features the ECP5-5G FPGA in the 381-ball caBGA package (LFE5UM5G-85F-8BG381) and the ability to expand the usability of the ECP5 with Arduino, Raspberry Pi, PMOD, MCD, and Versa headers, along with access to all SERDES channels. Over 170 I/Os and 20 differential pairs are available for user-defined applications.

Figure 1.1 shows the top view of the ECP5 Evaluation Board. Figure 1.2 shows the bottom view of the board. Figure 1.3 shows the jumper locations.

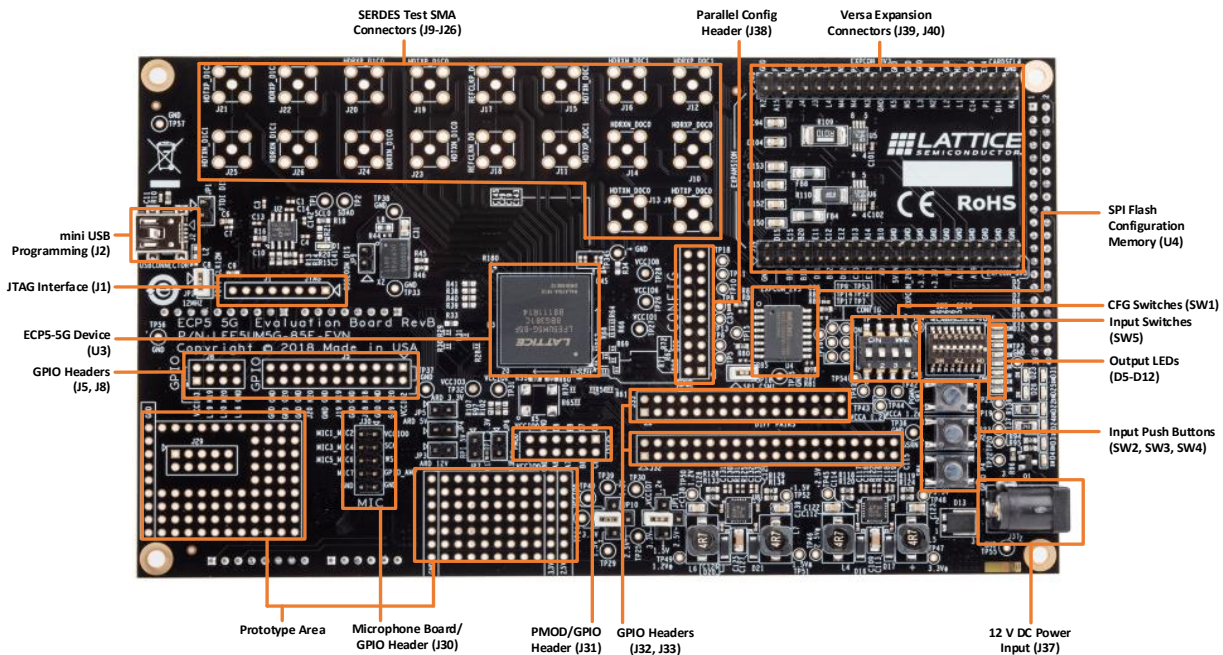

Figure 1.1. Top View of ECP5 Evaluation Board



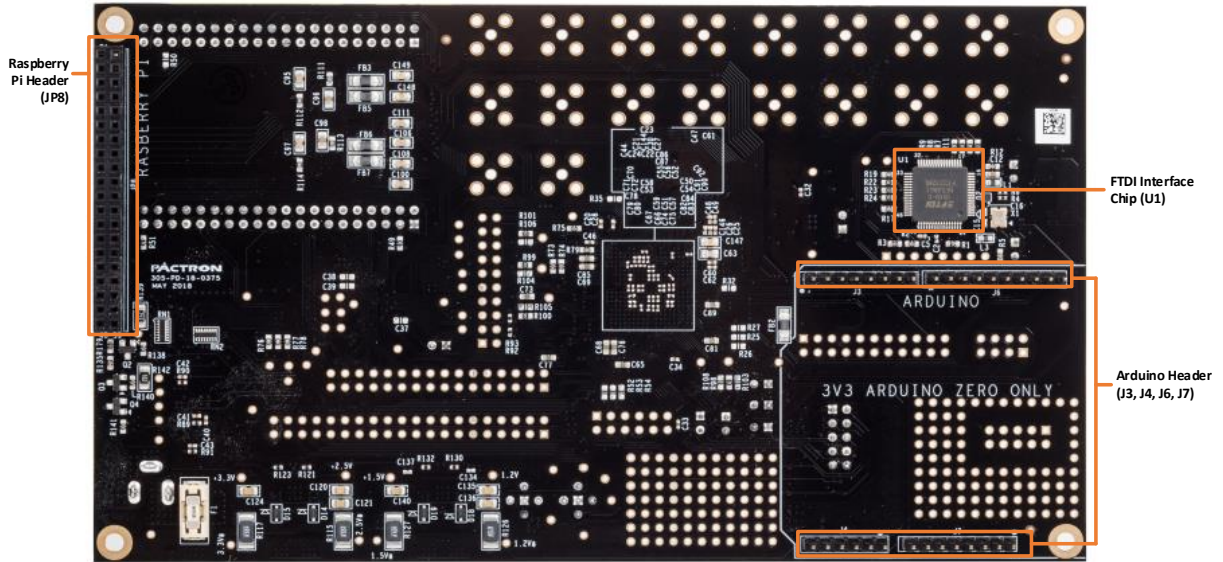

Figure 1.2. Bottom View of ECP5 Evaluation Board

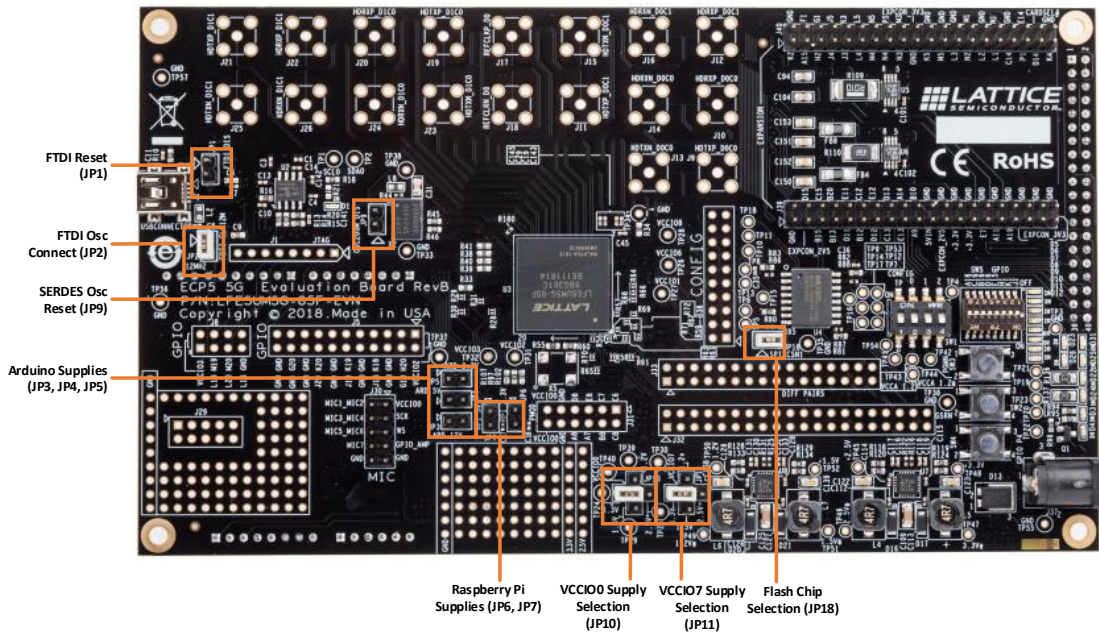

Figure 1.3. Top View of ECP5 Evaluation Board – Jumper Locations

## 1.2. Features

- ECP5-5G FPGA (LFE5UM5G-85F-8BG381)
- General Purpose Input/Output (GPIO) breakout with Arduino, Raspberry Pi, Versa, PMOD, and MDC board interconnect
- 178 General purpose I/Os, 20 differential pair I/Os with on board termination, 4 5G SERDES channels
- USB-B connection for device programming and Inter-Integrated Circuit (I<sup>2</sup>C) utility and ability to support Improved Inter-Integrated Circuit (I<sup>3</sup>C)
- On-board Boot Flash – 128 Mbit Serial Peripheral Interface (SPI) Flash, with Quad read feature
- 8 input DIP switches, 3 push buttons and 8 LEDs for demo purposes
- Lattice Diamond® programming support
- Multiple reference clock sources

**Caution:** The ECP5 Evaluation Board contains ESD-sensitive components. ESD safe practices should be followed while handling and using the development board.

## 1.3. ECP5 Device

The ECP5 Evaluation Board features the ECP5-5G in a 381-ball caBGA package. This ECP5-5G device, also referred to as LFE5UM5G-85F-8BG381, features 84,000 LUTs and 3744 kbits of embedded block RAM. This device offers a variety of features and programmability. For more information on the capabilities of ECP5™, see [ECP5 and ECP5-5G Family Data Sheet \(FPGA-DS-02012\)](#).



## 2. Applying Power to the Board

The ECP5 Evaluation Board has most of its power supplied by onboard regulators powered by an external 12 V power. In addition, the USB connection supplies 5 V to some components, and off board supplies can be used to supply the Raspberry Pi and Arduino headers. Jumpers or resistor installation/removal can be used to achieve several different power supply configurations. Refer to [Appendix A. ECP5 Evaluation Board Schematics](#) to see the details of these power supply options. [Figure 2.1](#) shows the high-level power supply architecture of the board. [Table 2.1](#) shows the voltage options available for the various VCCIO supplies.

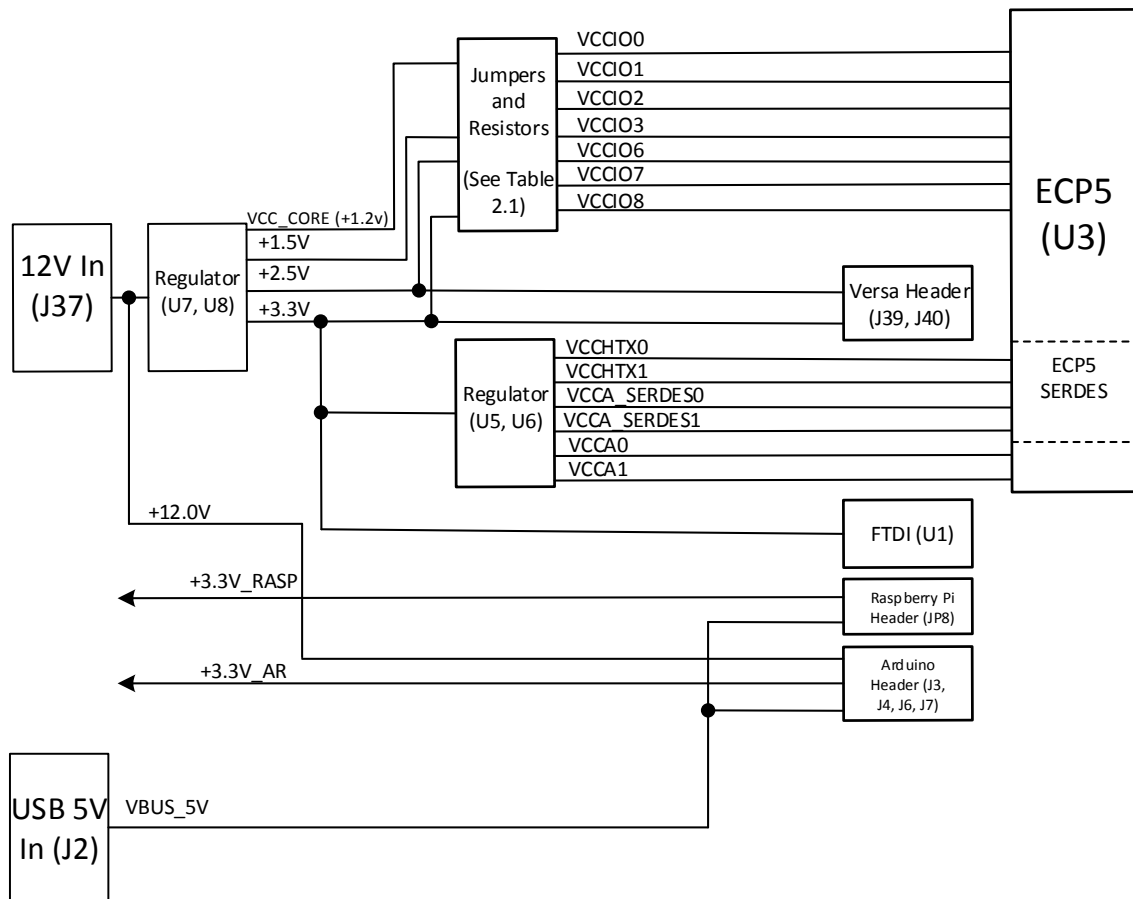

Figure 2.1. Board Power Supply

Table 2.1. ECP5 VCCIO Supply Options

VCCIO Bank	Selection	+3.3V	+2.5V	+3.3V_AR	+3.3V_RASP	+1.5V	VCC_CORE(+1.2V)
VCCIO0	Jumper (JP 10)	Default	Selectable	N/A	N/A	Selectable	Selectable
VCCIO1	Resistors	Selectable	Default	N/A	N/A	N/A	N/A
VCCIO2	Resistors	Default	Selectable	Selectable	N/A	N/A	N/A
VCCIO3	Resistors	Default	Selectable	N/A	Selectable	N/A	N/A
VCCIO6	Resistors	Default	Selectable	N/A	N/A	N/A	N/A
VCCIO7	Jumper (JP 11)	Default	Selectable	N/A	N/A	Selectable	Selectable
VCCIO8	Resistors	Default	Selectable	N/A	N/A	N/A	N/A

**Warning:** Only one option should be enabled for each ECP5 device I/O Bank. The implementation of these options can be found in [Figure A. 11](#).

### 3. Programming and I<sup>2</sup>C

The JTAG/SPI programming architecture and I<sup>2</sup>C interface of the ECP5 Evaluation Board is shown in [Figure 3.1](#).

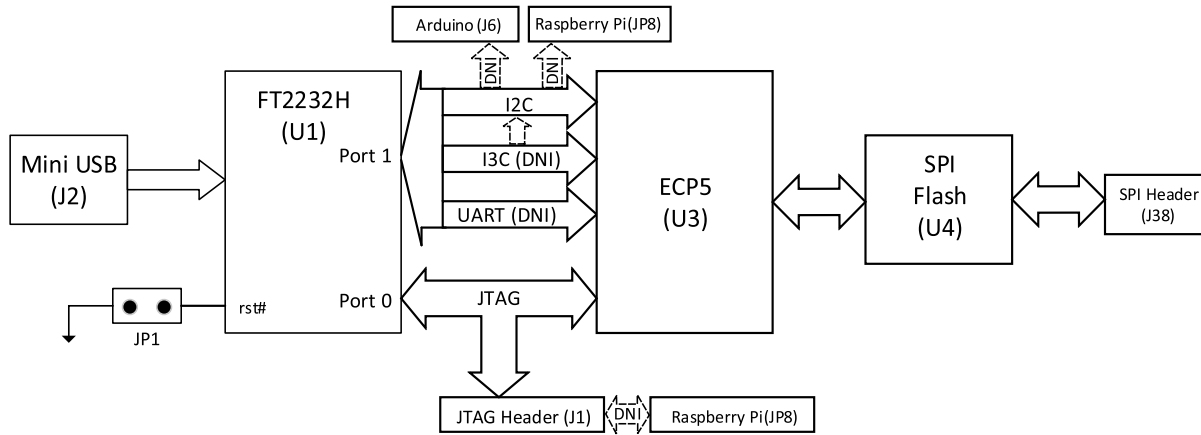

**Figure 3.1. Configuration and I<sup>2</sup>C Architecture**

#### 3.1. JTAG Download Interface

The ECP5 Evaluation Board has a built-in download controller for programming the ECP5-5G device. It uses an FT2232H Future Technology Devices International (FTDI) part to convert USB to JTAG. To use the built-in download cable, connect the USB cable from the mini USB to your PC, that is, with Diamond programming software installed. A mini USB to USB-A cable is included in the ECP5 Evaluation Kit. The USB hub on the PC detects the cable of the USB function on Port 0, making the built-in cable available for use with the Diamond programming software.

#### 3.2. Alternate JTAG Download Interface

J1 is an 8-pin standalone JTAG header used with an external Lattice download cable that is available separately, when the FTDI part is disabled from the JTAG chain after setting the JP1 jumper. A USB download cable can be attached to the board using J1 to interface with the ECP5-5G. For details on the connection between the USB download cable and J1, refer to [Programming Cable User’s Guide \(FPGA-UG-02042\)](#).

J1 can also be used as test point when USB to JTAG is working. Additionally, you can enable the JTAG access path through the Raspberry Pi header (JP8) for customer applications. This is done by connecting the JP8 header to the J1 header through some onboard resistors. The JTAG connections between J1 and JP8 are listed in [Table 3.1](#).

**Table 3.1. JTAG Connections**

J1 Pin Number	JTAG Signal Name	ECP5-5G Ball Location for JTAG	Raspberry Pi Header (JP8) Pin Number	J1 to JP8 Isolation (Assembly)	Raspberry Pi GPIO
1	VCCIO8	—	—	—	—
2	TDO	V4	10	R39 (DNI)	IO15
3	TDI	R5	11	R40 (DNI)	IO17
4	—	—	—	—	—
5	—	—	—	—	—
6	TMS	U5	12	R41 (DNI)	IO18
7	GND	—	—	—	—
8	TCK	T5	8	R38 (DNI)	IO14

### 3.3. JTAG to MSPI Pass-through Interface

The download controller can also access the JTAG to MSPI pass-through circuit that allows the slave SPI Flash to be erased, programmed, and read with Diamond Programmer.

### 3.4. Other JTAG Configuration Pins

The ECP5 Evaluation Board provides test points for other JTAG configuration pins as shown in [Table 3.2](#).

**Table 3.2. Other JTAG Signals**

Signal Name	ECP5-5G Ball Location	Test Point
PROGRAMN	W3	TP21
INITN	V3	TP20
DONE	Y3	TP22

For more information on ECP5 JTAG and SPI programming, refer to [ECP5 and ECP5-5G sysCONFIG Usage Guide \(FPGA-TN-02039\)](#).

### 3.5. Configuration Modes

The ECP5 can be configured in Master SPI, Slave SPI, SCM, JTAG, and SPCM modes. These modes can be selected using the CFGMDN switches provided on the board (detailed in the [DIP Switch](#) section and [ECP5 and ECP5-5G sysCONFIG Usage Guide \(FPGA-TN-02039\)](#). [Table 3.3](#) below details the CFGMDN settings that are used to select individual configuration modes.

**Table 3.3. CFGMDN Mode Settings**

Configuration Mode	Bus Size	Options	Clock	CFGMDN2	CFGMDN1	CFGMDN0
SSPI	1	—	CCLK	0	0	1
MSPI	1	Serial (SPI_Serial)	MCLK	0	1	0
	2	Dual (SPI_Dual)				
	4	Quad (SPI_Quad)				
	1, 2, 4	Dual-Boot				
	1, 2, 4	Multi-Boot				
SCM (Slave_Serial)	1	—	CCLK	1	0	1
SPCM (Slave_Parallel)	8	—	CCLK	1	1	1

## 4. ECP5 Clock Sources

The ECP5 Evaluation Board has three options for the ECP5-5G clock sources:

- 12 MHz from U1 FTDI Chip
- 200 MHz SERDES clock from X2 Differential Oscillator. For different user applications, the X2 footprint accepts commonly-available devices of different frequencies.
- X5 oscillator for LVDS source sync clock. X5 is not populated by default. For convenience, a 50 MHz device is specified in the [ECP5 Evaluation Board Bill of Materials](#) section, Item 127. Other frequency devices may be mounted as desired.

The 12 MHz clock from the FT2232H FTDI device requires JP2 to be installed to connect the 12 MHz clock signal to the ECP5 device I/O. JP1 should not be installed to enable U1.

**Table 4.1. Clock Sources**

Clock Frequency	Signal Name	ECP5 Ball Location	Clock Source	Comments
12 MHz	12 MHz	A10	U1	JP2 installed. JP1 removed.
200 MHz	200 MHz/200 MHz_n	Y19/ W20	X2	JP9 added to disable.
50 MHz	50 MHz_OSC	B11	X5 (DNI)	50 MHz_OSC_EN (C11) to enable/disable.

## 5. Headers and Test Connections

This section describes the ECP5 Evaluation Board headers and test connections.

### 5.1. Versa Headers

The board provides two headers – J39 and J40 which can be used for expansion or as general purpose I/O connections.

**Table 5.1. Versa J39 Header Pin Connections**

J39 Pin Number	Signal Name	ECP5-5G-85 Ball
1	GND	—
2	NC	—
3	EXPCON_2V5*	—
4	D15	D15
5	B15	B15
6	C15	C15
7	B13	B13
8	B20	B20
9	D11	D11
10	E11	E11
11	B12	B12
12	C12	C12
13	D12	D12
14	E12	E12
15	C13	C13
16	D13	D13
17	E13	E13
18	A14	A14
19	A9	A9
20	B10	B10
21	5VIN	—
22	GND	—
23	EXPCON_2V5*	—
24	GND	—
25	+3.3V	—
26	GND	—
27	+3.3V	—
28	GND	—
29	E7	—
30	GND	—
31	A11	A11
32	GND	—
33	A19	A19
34	GND	—
35	EXPCON_3V3*	—

J39 Pin Number	Signal Name	ECP5-5G-85 Ball
36	GND	—
37	EXPCON_3V3*	—
38	GND	—
39	EXPCON_3V3*	—
40	GND	—

\*Note: Signal is connected to power source through removable resistor.

**Table 5.2. Versa J40 Header Pin Connections**

J40 Pin Number	Signal Name	ECP5-5G-85 Ball
1	K2	K2
2	GND	—
3	A15	A15
4	F1	F1
5	H2	H2
6	G1	G1
7	J4	J4
8	J5	J5
9	J3	J3
10	K3	K3
11	L4	L4
12	L5	L5
13	M4	M4
14	N5	N5
15	N4	N4
16	P5	P5
17	N3	N3
18	M3	M3
19	GND	—
20	EXPCON_3V3*	—
21	K5	K5
22	GND	—
23	M5	M5
24	GND	—
25	L3	L3
26	GND	—
27	N2	N2
28	M1	M1
29	L2	L2
30	GND	—
31	L1	L1
32	N1	N1
33	C14	C14

J40 Pin Number	Signal Name	ECP5-5G-85 Ball
34	GND	—
35	P1	P1
36	E14	E14
37	D14	D14
38	CARDSEL#*	—
39	K4	K4
40	GND	—

\*Note: Signal is connected to power source through removable resistor.

## 5.2. Arduino Board GPIO Headers

The board provides four headers – J3, J4, J6 and J7 for Arduino Zero board adaption or as general purpose I/O connections.

**Table 5.3. Arduino J6 Pin Connections**

J6 Pin Number	Signal Name	Arduino ZERO Board Signal	ECP5-5G-85 Ball	Comments
1	AR_IO8	~8	K16	—
2	AR_IO9	~9	J16	—
3	AR_SS_IO10	~10	H17	—
4	AR_MOSI_IO11	~11	J17	—
5	AR_MISO_IO12	~12	H18	—
6	AR_SCK_IO13	~13	H16	—
7	GND	GND	—	—
8	AR_AREF	AREF	G18	AR_AREF connection to AREF through R27, DNI by default.
9	AR_SDA	SDA	G16	Optional connection to SDA0 through R26, DNI by default.
10	AR_SCL	SCL	F17	Optional connection to SCL0 through R25, DNI by default.

**Table 5.4. Arduino J3 Pin Connections**

J3 Pin Number	Signal Name	Arduino ZERO Board Signal	ECP5-5G-85 Ball	Comments
1	AR_IO0	RX <- 0	F19	—
2	AR_IO1	TX -> 1	F20	—
3	AR_IO2	2	E20	—
4	AR_IO3	~3	E19	—
5	AR_IO4	~4	D19	—
6	AR_IO5	~5	D20	—
7	AR_IO6	~6	C20	—
8	AR_IO7	7	K17	—



**Table 5.5. Arduino J7 Pin Connections**

J7 Pin Number	Signal Name	Arduino ZERO Board Signal	ECP5-5G-85 Ball	Comments
1	AR_IO14	ATN	C18	—
2	NC	IOREF	—	—
3	AR_RESET	RESET	D17	Pin D17 should be set high by default. Avoid Arduino ZERO board in Reset status when connected.
4	+3.3V_AR	3.3 V	—	Jumper to 3.3 V power supply from Arduino ZERO board
5	VBUS_5V	5 V	—	Jumper to 5 V USB power
6	GND	GND	—	—
7	GND	GND	—	—
8	+12.0V	VIN	—	Jumper to +12.0V power supply from Arduino ZERO board

**Table 5.6. Arduino J4 Pin Connections**

J4 Pin Number	Signal Name	Arduino ZERO Board Signal	ECP5-5G-85 Ball	Comments
1	AR_AD0	A0	F18	Used as GPIO in digital mode
2	AR_AD1	A1	E17	Used as GPIO in digital mode
3	AR_AD2	A2	E18	Used as GPIO in digital mode
4	AR_AD3	A3	D18	Used as GPIO in digital mode
5	AR_AD4	A4	F16	Used as GPIO in digital mode
6	AR_AD5	A5	E16	Used as GPIO in digital mode

**Note:** For [Table 5.3](#), [Table 5.4](#), [Table 5.5](#), and [Table 5.6](#), if jumper to VBUS\_5V is installed, 5 V power can be supplied from either the Arduino board or the ECP5 Evaluation Board. With jumper removed, both boards need their own 5 V power.

### 5.3. Raspberry Pi Board GPIO Header

The ECP5 Evaluation Board provides a 40-pin receptacle which is compatible with the GPIO header of Raspberry Pi 2/3 serial models, or can be used for general purpose I/Os.

**Table 5.7. Raspberry Pi JP8 Header Pin Connections**

JP8 Pin Number	Signal Name	ECP5-5G-85 Ball
1	+3.3V_RASP <sup>1</sup>	—
2	RASP_5V <sup>2</sup>	—
3	RASP_IO02	T17
4	RASP_5V <sup>2</sup>	—
5	RASP_IO03	U16
6	GND	—
7	RASP_IO04	U17
8	RASP_IO14	P18
9	GND	—
10	RASP_IO15	N20
11	RASP_IO17	N19
12	RASP_IO18	T16
13	RASP_IO27	M18
14	GND	—
15	RASP_IO22	N17
16	RASP_IO23	P17
17	3.3V_RASP <sup>1</sup>	—
18	RASP_IO24	M17
19	RASP_IO10	U20
20	GND	—
21	RASP_IO09	T19
22	RASP_IO25	N18
23	RASP_IO11	R20
24	RASP_IO08	U19
25	GND	—
26	RASP_IO07	R18
27	RASP_ID_SD	L18
28	RASP_ID_SC	L17
29	RASP_IO05	U18
30	GND	—
31	RASP_IO06	T18
32	RASP_IO12	T20
33	RASP_IO13	P20
34	GND	—
35	RASP_IO19	R17
36	RASP_IO16	P19
37	RASP_IO26	N16
38	RASP_IO20	P16

JP8 Pin Number	Signal Name	ECP5-5G-85 Ball
39	GND	—
40	RASP_IO21	R16

**Notes:**

- 3.3 V power is supplied from Raspberry Pi board.
- 5 V power can come from either the Raspberry Pi board or the ECP Evaluation Board (via USB) when jumper JP7 is installed. When jumper JP7 is not installed, both boards need their own 5 V power.

## 5.4. GPIO Headers

There are two types of general purpose I/O headers: simple general purpose headers, and differential general purpose headers. The differential headers have associated termination resistors for each differential I/O pair.

**Table 5.8. J5 Header Pin Connections**

J5 Pin Number	Signal Name	ECP5-5G-85 Ball	Differential Pair
1	VCCIO2	—	—
2	VCCIO2	—	—
3	H20	H20	H20/G19
4	G19	G19	H20/G19
5	GND	—	—
6	GND	—	—
7	K18	K18	K18/J18
8	J18	J18	K18/J18
9	GND	—	—
10	GND	—	—
11	K19	K19	K19/J19
12	J19	J19	K19/J19
13	GND	—	—
14	GND	—	—
15	K20	K20	K20/J20
16	J20	J20	K20/J20
17	GND	—	—
18	GND	—	—
19	G20	G20	—
20	GND	—	—
21	GND	—	—
22	GND	—	—

**Table 5.9. J8 Header Pin Connections**

J8 Pin Number	Signal Name	ECP5-5G-85 Ball
1	VCCIO3	—
2	VCCIO3	—
3	L19	L19
4	M19	M19
5	L20	L20
6	M20	M20
7	L16	L16
8	GND	—

**Table 5.10. J32 Header Pin Connections**

J32 Pin Number	Signal Name	ECP5-5G-85 Ball	Differential Pair
1	NC	—	—
2	VCCIO7	—	—
3	GND	—	—
4	GND	—	—
5	A5	A5	A5/A4
6	A4	A4	A5/A4
7	GND	—	—
8	GND	—	—
9	C5	C5	C5/B5
10	B5	B5	C5/B5
11	GND	—	—
12	GND	—	—
13	B4	B4	B4/C4
14	C4	C4	B4/C4
15	GND	—	—
16	GND	—	—
17	B3	B3	B3/A3
18	A3	A3	B3/A3
19	GND	—	—
20	GND	—	—
21	D5	D5	D5/E4
22	E4	E4	D5/E4
23	GND	—	—
24	GND	—	—
25	D3	D3	D3/C3
26	C3	C3	D3/C3
27	GND	—	—
28	GND	—	—
29	E3	E3	E3/F4
30	F4	F4	E3/F4

J32 Pin Number	Signal Name	ECP5-5G-85 Ball	Differential Pair
31	GND	—	—
32	GND	—	—
33	F5	F5	F5/E5
34	E5	E5	F5/E5
35	GND	—	—
36	GND	—	—
37	B1	B1	B1/A2
38	A2	A2	B1/A2
39	GND	—	—
40	GND	—	—

**Table 5.11. J33 Header Pin Connections**

J33 Pin Number	Signal Name	ECP5-5G-85 Ball	Differential Pair
1	NC	—	—
2	VCCIO7	—	—
3	GND	—	—
4	GND	—	—
5	C2	C2	C2/B2
6	B2	B2	C2/B2
7	GND	—	—
8	GND	—	—
9	D1	D1	D1/C1
10	C1	C1	D1/C1
11	GND	—	—
12	GND	—	—
13	E1	E1	E1/D2
14	D2	D2	E1/D2
15	GND	—	—
16	GND	—	—
17	G5	G5	G5/H4
18	H4	H4	G5/H4
19	GND	—	—
20	GND	—	—
21	H3	H3	H3/H5
22	H5	H5	H3/H5
23	GND	—	—
24	GND	—	—
25	F3	F3	F3/G3
26	G3	G3	F3/G3
27	GND	—	—
28	GND	—	—
29	E2	E2	E2/F2

J33 Pin Number	Signal Name	ECP5-5G-85 Ball	Differential Pair
30	F2	F2	E2/F2
31	GND	—	—
32	GND	—	—

## 5.5. Microphone Expansion Header

The J30 header can be used as GPIO, or can mate to the 8:1 Microphone Aggregator Board. It is placed with a non-connected header in close proximity to allow the physical pairing of the boards.

**Table 5.12. J30 Header Pin Connections**

J30 Pin Number	Signal Name	ECP5-5G-85 Ball
1	VCCIO0	—
2	I2S_SD_mic1_mic2_card_B6	B6
3	I2S_SCK_mic_D9	D9
4	I2S_SD_mic3_mic4_C9	C9
5	I2S_WS_mic_E9	E9
6	I2S_SD_mic5_mic6_D10	D10
7	GPIO_amp_A6	A6
8	I2S_SD_mic7_E10	E10
9	GND	—
10	GND	—

## 5.6. PMOD Header

The J31 header can be used as GPIO or as a connector to a PMOD interface.

**Table 5.13. J31 Header Pin Connections**

J31 Pin Number	Signal Name	ECP5-5G-85 Ball
1	C6	C6
2	C7	C7
3	E8	E8
4	D8	D8
5	GND	—
6	VCCIO0	—
7	C8	C8
8	B8	B8
9	A7	A7
10	A8	A8
11	GND	—
12	VCCIO0	—

## 5.7. JTAG Header

The J1 header is used to access the JTAG port of the ECP5 or the Raspberry Pi interface.

**Table 5.14. J1 Header Pin Connections**

J1 Pin Number	Signal Name	ECP5-5G-85 Ball
1	VCCIO8	—
2	TDO	V4
3	TDI	R5
4	NC	—
5	NC	—
6	TMS	U5
7	GND	—
8	TCK	T5

## 5.8. Parallel Configuration Header

The J38 header is used to access the SPI port of the ECP5 or the Raspberry Pi interface.

**Table 5.15. J38 Header Pin Connections**

J38 Pin Number	Signal Name	ECP5-5G-85 Ball
1	PROGRAMN	W3
2	FLASH_CS	R2 (with jumper)
3	WRITEN	T3
4	DONE	Y3
5	DQ7	R1
6	INITN	V3
7	DQ6	T1
8	DQ1_MISO	V2
9	DQ5_MISO2	U1
10	DQ0_MOSI	W2
11	DQ4_MOSI2	V1
12	CSN	T2
13	DQ3	W1
14	CS1N	U2
15	DQ2	Y2
16	BUSY_CSSPIN	R2
17	CCLK_MCLK_SCK	U3
18	DOUT_CSON	R3
19	GND	—
20	VCCIO8	—



## 6. Control Buses - I<sup>2</sup>C, I<sup>3</sup>C, UART, and SPI

This section describes the topology of the various configuration and communication buses.

### 6.1. I<sup>2</sup>C and I<sup>3</sup>C Topology

The ECP5 Evaluation Board uses the I<sup>2</sup>C bus to support ECP5 configuration, and optionally to support Arduino and Raspberry Pi communication. The global I<sup>2</sup>C bus has the signal names SDA0 and SCL0 and they are routed close to the devices and headers as shown in [Figure 3.1](#) and in more detail in [Figure 6.1](#).

To support the Arduino and Raspberry Pi, each header or device is connected to a dedicated ECP5 GPIO bank with a direct local I<sup>2</sup>C bus. Each local I<sup>2</sup>C bus can optionally connect to the global I<sup>2</sup>C bus through resistors. The local I<sup>2</sup>C connections are summarized in [Table 6.1](#).

**Table 6.1. I<sup>2</sup>C Global Bus Connections**

ECP5 Bank	Component (Reference)	Header Pin	ECP5-5G-85 Ball	Local Signal Name (Global I <sup>2</sup> C Signal)	Resistor
2	Arduino header (J6)	9	G16	AR_SDA (SDA0)	R26 (DNI)
		10	F17	AR_SCL (SCL0)	R25 (DNI)
3	Raspberry Pi header (JP8)	27	L18	RASP_ID_SD (SDA0)	R33 (DNI)
		28	L17	RASP_ID_SC (SCL0)	R32 (DNI)

The board also has the option to switch to an I<sup>3</sup>C interface by removing the installed 2.2 k $\Omega$  I<sup>2</sup>C pull-up resistors (R18 and R19) and installing I<sup>3</sup>C resistors (R52 at 2.2 k $\Omega$ , R53 at 100 k $\Omega$ , or R54 at 100 k $\Omega$ ) as shown in [Figure 6.1](#).

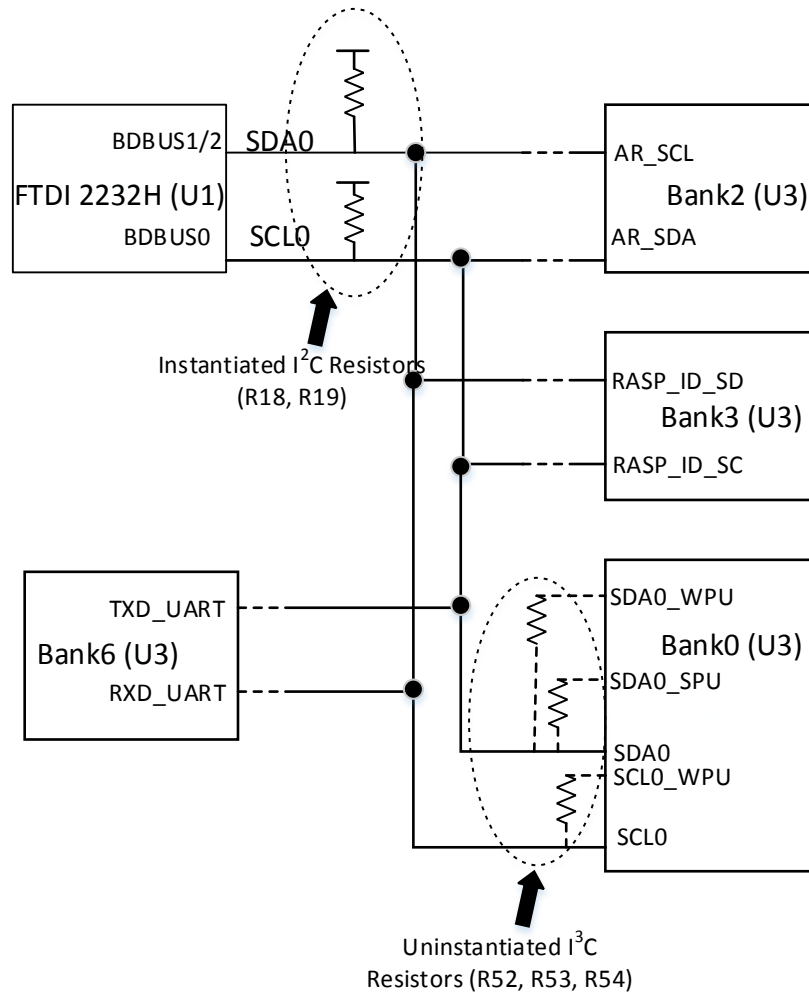

Figure 6.1. I<sup>2</sup>C Architecture, I<sup>3</sup>C, and UART Options

## 6.2. UART Topology

The board provides support for UART configuration by providing an uninstalled connection between the FTDI and ECP5. Two 0 Ω resistors (R34 and R35) can be installed to connect Port 1 to two general purpose I/Os (PL92A/P2 and PL92C/P3) in Bank 6 as shown in [Figure 6.1](#).

## 6.3. SPI Topology

### 6.3.1. SPI Configuration

One of the major functions of SPI connections on the board is to support ECP5 configuration from the SPI Flash or the Parallel Configuration Header. The ECP5 Evaluation Board can support both Master SPI (MSPI) and Slave SPI (SSPI) modes for ECP5 configuration. [Figure 6.2](#) from the schematics show the connections between the header, Flash chip, and FPGA.

**Table 6.2. ECP5 SPI Connections**

Signal Name	ECP5-5G-85 Ball	Parallel Configuration Header Pin	MSPI Mode Direction	SSPI Mode Direction
CCLK_MCLK_SCK	U3	17	Output	Input
DQ0_MOSI	W2	10	Output	Input
DQ1_MISO	V2	8	Input	Output
BUSY_CSSPIN	R2	16	Output	Not used
DQ2	Y2	15	Input	Not used
DQ3	W1	13	Input	Not used

### 6.3.2. SPI Flash Access

Onboard SPI Flash memory can be used to store the ECP5 configuration data in either External or Dual Boot mode. It can also store customer data in certain applications. The ECP5 device includes the JTAG to MSPI pass-through circuit that allows the slave SPI Flash to be erased, programmed, and read with Diamond Programmer. For detailed information on JTAG to MSPI pass-through for slave SPI Flash access, refer to [ECP5 and ECP5-5G sysCONFIG Usage Guide \(FPGA-TN-02039\)](#).

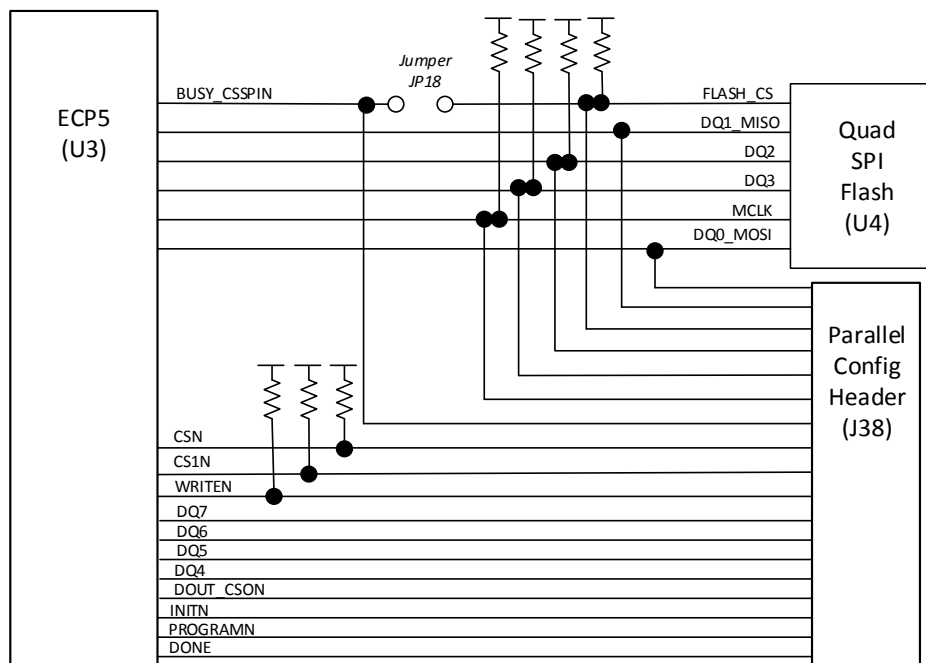

**Note:** See schematics for complete INITN, PROGRAMN, and DONE connections.

**Figure 6.2. SPI Interface**

## 7. LEDs and Switches

This section describes the ECP5 Evaluation Board LEDs and switches that can be used in demo and customer designs.

### 7.1. DIP Switch

Eight ECP5 pins are connected to the SW5 DIP switch to allow for manually actuated inputs to the FPGA. One side of each switch is connected to GPIOs within the VCCIO6 and VCCIO1 bank and pulled up through 4.7 kΩ resistors. The other side is grounded. The designated pins are connected as shown in [Table 7.1](#).

**Table 7.1. Eight-Position DIP Switch Signals**

Signal Name	ECP5-5G-85 Ball	ECP5-5G-85 Bank	SW5 DIP Switch Position
SWITCH1	J1	6	1
SWITCH2	H1	6	2
SWITCH3	K1	6	3
SWITCH4	E15	1	4
SWITCH5	D16	1	5
SWITCH6	B16	1	6
SWITCH7	C16	1	7
SWITCH8	A16	1	8

### 7.2. Configuration Mode Switch

A DIP switch is provided to allow the selection of the configuration mode between SSPI, MSPI, SCM, and SPCM as specified in [ECP5 and ECP5-5G sysCONFIG Usage Guide \(FPGA-TN-02039\)](#). [Table 7.2](#) lists the connectivity of this switch (SW1).

**Table 7.2. CFGMDN Switch Signals**

Signal Name	Functional Name	ECP5-5G-85 Ball	ECP5-5G-85 Bank	SW1 DIP Switch Position
CFG0	CFGMDN0	U4	6	2
CFG1	CFGMDN1	T4	6	3
CFG2	CFGMDN2	R4	6	4

### 7.3. General Purpose Push Buttons

The ECP5 Evaluation Board provides three push button switches – SW2, SW3 and SW4 for demos and user applications. Two of the buttons control pre-defined functional pins, and the third is generic. Pressing these buttons drives a logic level “0” to the corresponding I/O pins.

**Table 7.3. Push Button Switch Signals**

Signal Name	ECP5-5G-85 Ball	Push Button Reference	Logic Level at Button Pressed
GSRN	G2	SW2	0
PROGRAMN	W3	SW3	0
BUTTON_1	P4	SW4	0

SW3 is used as a PROGRAMN push button to trigger the configuration process without power cycle. For detailed information on PROGRAMN, refer to [ECP5 and ECP5-5G sysCONFIG Usage Guide \(FPGA-TN-02039\)](#). SW2 is intended to be used as a global set/reset pin when active low, but can be substituted for another function if the user desires. SW3 can be used as a generic input.

## 7.4. General Purpose LEDs

The ECP5 Evaluation Board provides eight red LEDs that are connected to I/Os within Bank 1. The LEDs are lighted when the output is driven LOW.

**Table 7.4. General Purpose LED Signals**

Signal Name	ECP5-5G-85 Ball	ECP5-5G-85 Bank
LED0	A13	1
LED1	A12	1
LED2	B19	1
LED3	A18	1
LED4	B18	1
LED5	C17	1
LED6	A17	1
LED7	B17	1

## 7.5. Indicator LEDs

Table 7.5 lists various LEDs and describes their purpose.

**Table 7.5. Various LED Signals**

LEDs	Signal Name	ECP5-5G-85 Ball	Color	Purpose
D1	UART_ACT	P3	Green	If installed, lights in UART mode
D3	INITN	V3	Red	Lights if configuration error
D4	DONE	Y3	Green	Lights if successful configuration
D22	VCCA0	—	Green	Lights if voltage present
D23	+1.5V	—	Green	Lights if voltage present
D24	+1.2V/VCC_CORE	—	Green	Lights if voltage present
D25	+3.3V	—	Green	Lights if voltage present
D26	+12.0V	—	Blue	Lights if voltage present (external connection)
D31	+2.5V	—	Green	Lights if voltage present

## 8. Software Requirements

The following software versions are required to develop designs for the ECP5 Evaluation Board:

- Diamond 3.10
- Diamond Programmer 3.10
- LatticeMico System Development Tools

## 9. Storage and Handling

Static electricity can shorten the life span of electronic components. Observe these tips to prevent damage that can occur from electrostatic discharge:

- Use antistatic precautions such as operating on an antistatic mat and wearing an antistatic wristband.
- Store the development board in the provided packaging.
- Touch a metal USB housing to equalize voltage potential between you and the board.

## 10. Ordering Information

**Table 10.1. Ordering Information**

Description	Ordering Part Number	China RoHS Environment-Friendly Use Period (EFUP)
ECP5 Evaluation Board	LFE5UM5G-85F-EVN	

## References

### Lattice Semiconductor Documents

Related documents available from your Lattice Semiconductor sales representative are listed on the table below.

Document	Title
FPGA-UG-02042	<i>Programming Cables</i>
FPGA-DS-02012	<i>ECP5 and ECP5-5G Family Data Sheet</i>
FPGA-TN-02039	<i>ECP5 and ECP5-5G sysCONFIG Usage Guide</i>
EB103	<i>ECP5-5G Versa Development Board User Guide</i>
FPGA-EB-02004	<i>MachXO3-9400 Development Board User Guide</i>



## Technical Support Assistance

Submit a technical support case through [www.latticesemi.com/techsupport](http://www.latticesemi.com/techsupport).

## Appendix A. ECP5 Evaluation Board Schematics

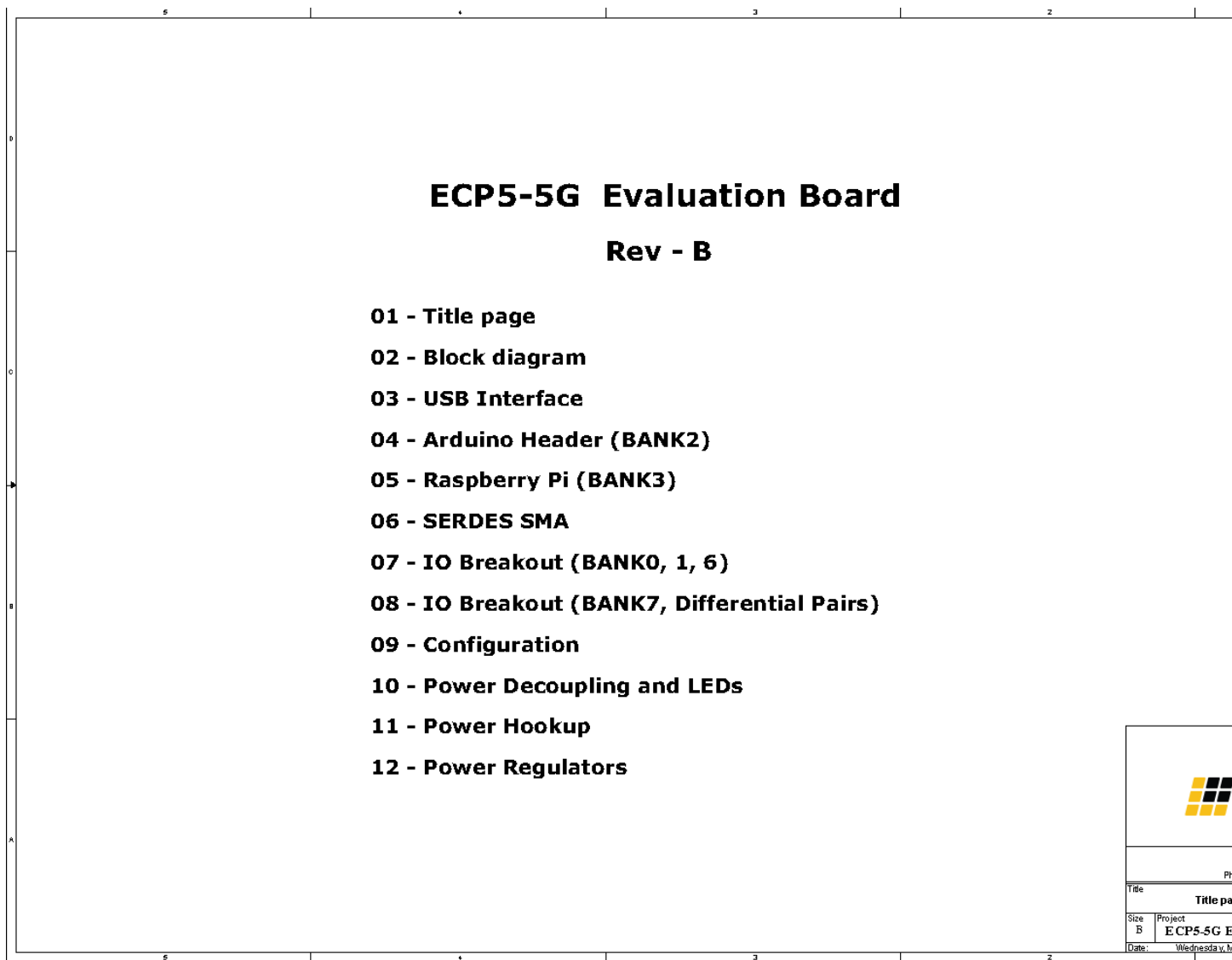

Figure A. 1. Title Page

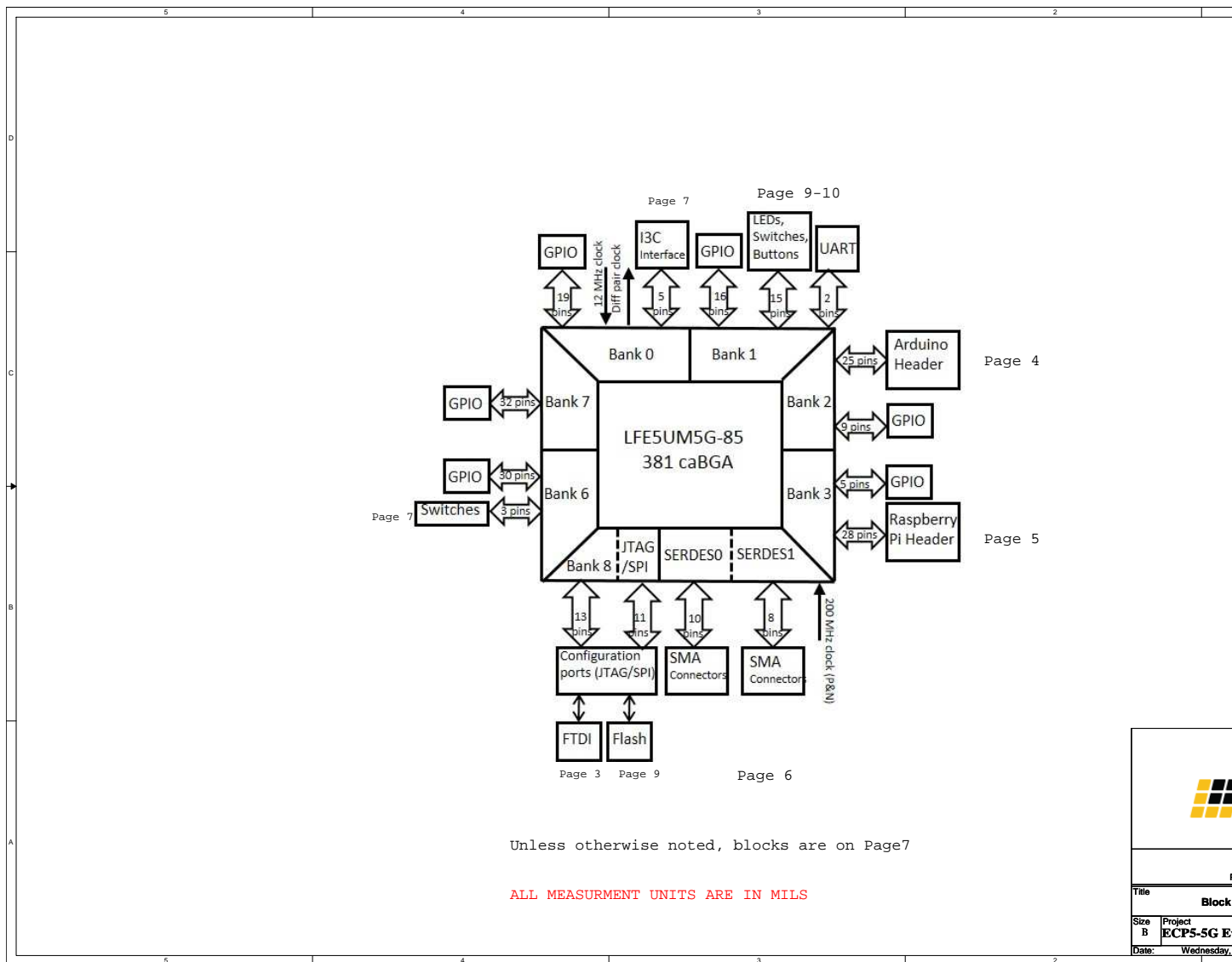

Figure A. 2. Block Diagram



ECP5™ Evaluation Board  
User Guide

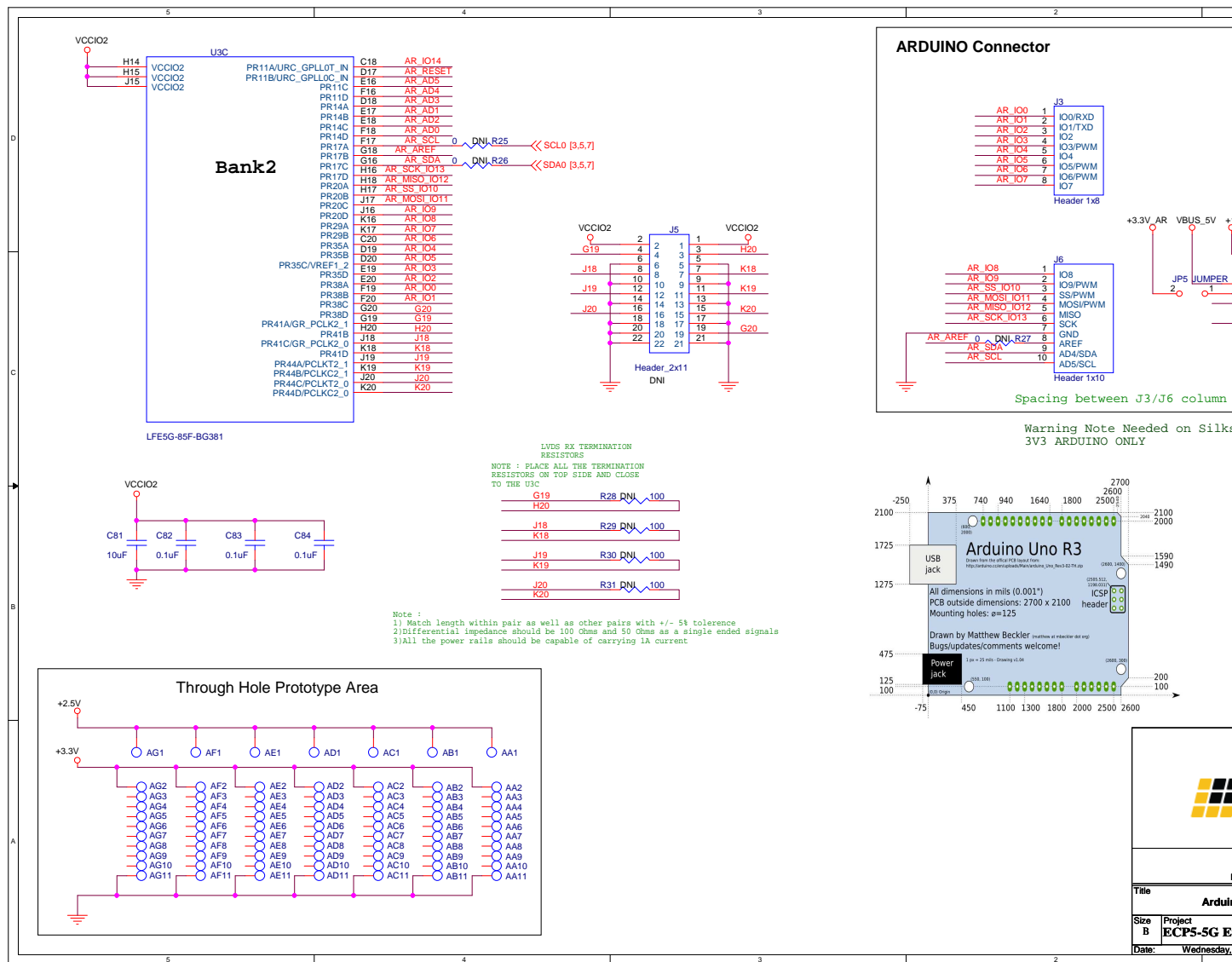

Figure A. 4 Arduino Header (BANK2)

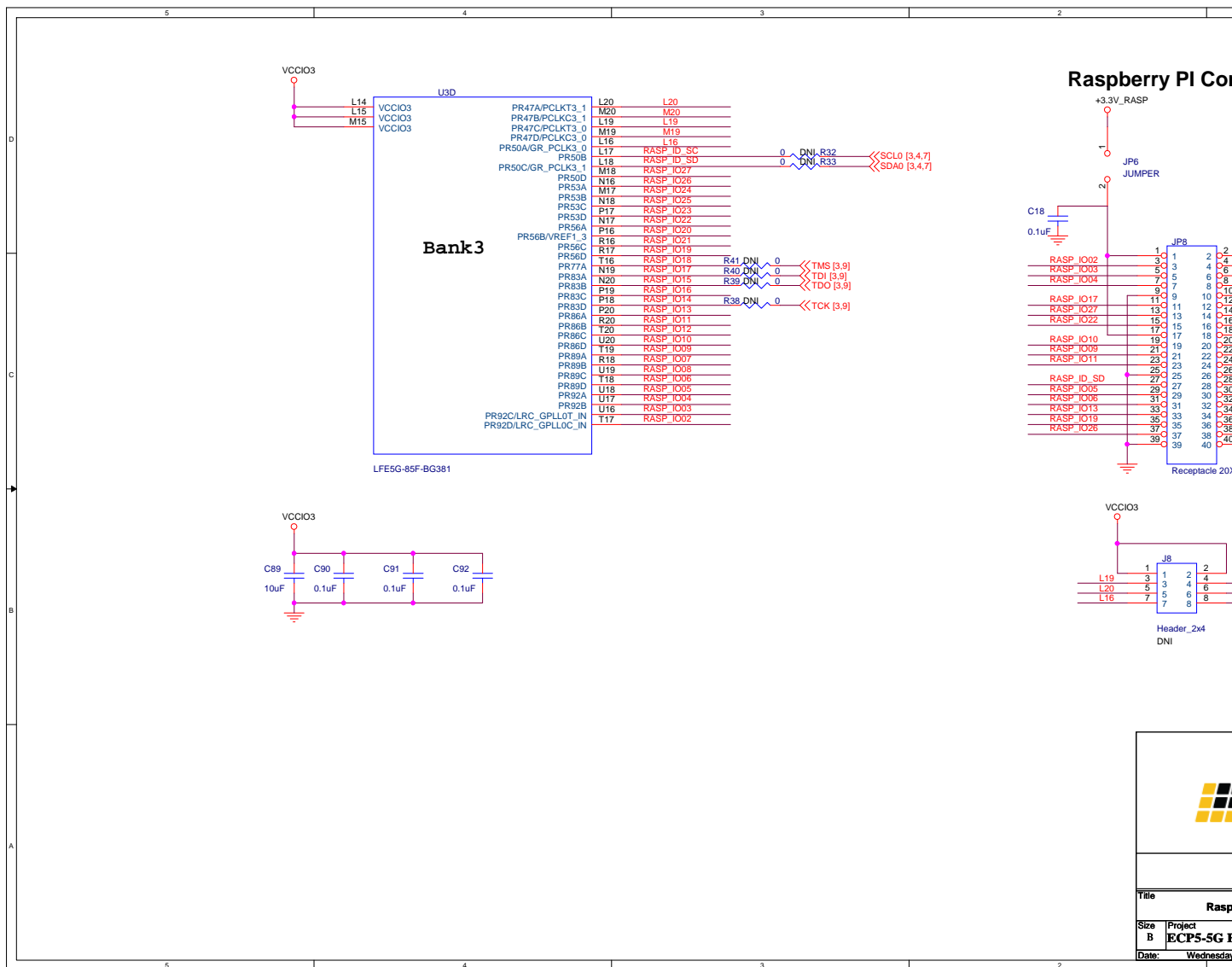

Figure A. 5. Raspberry Pi Header (BANK3)

ECP5™ Evaluation Board  
User Guide

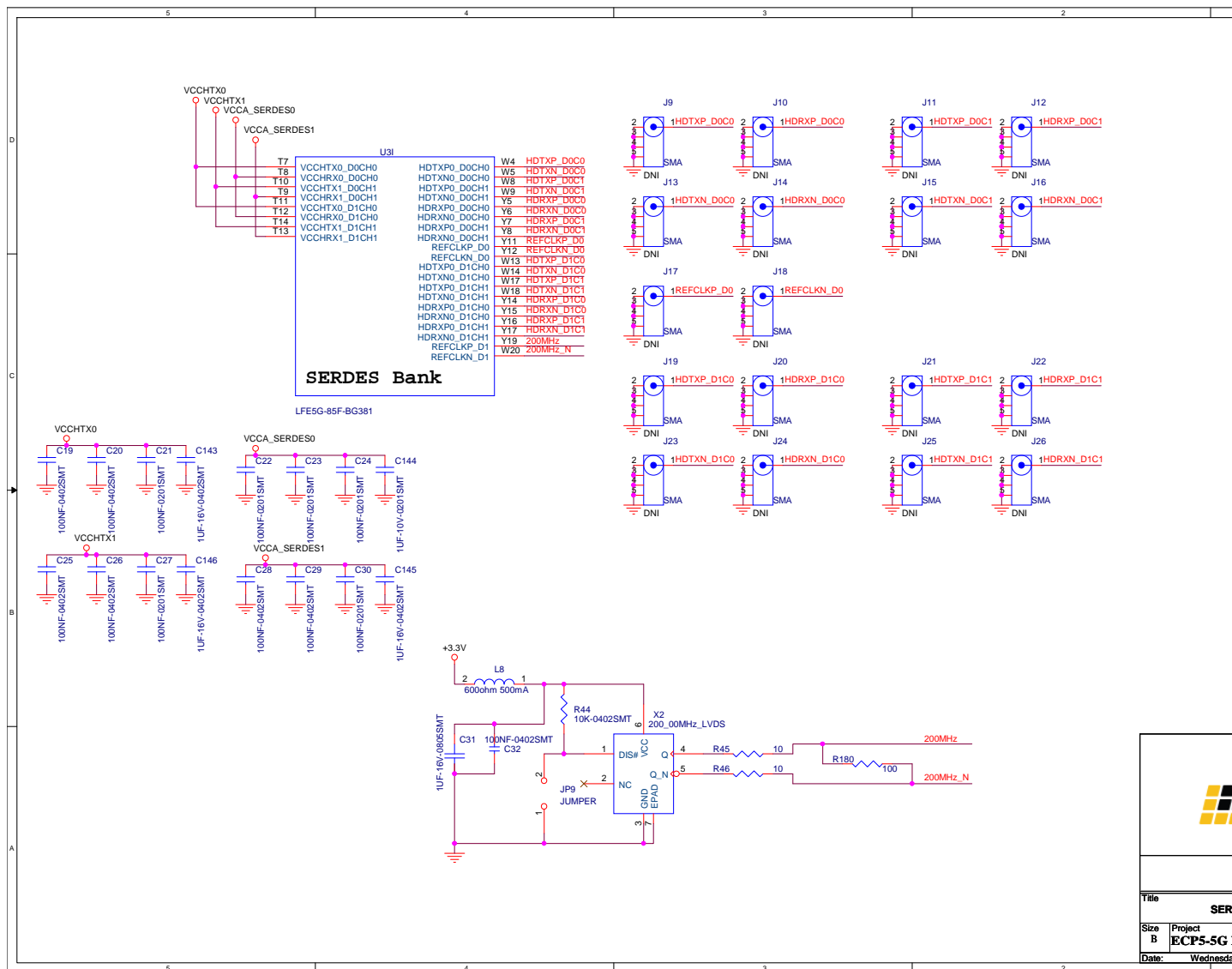

Figure A. 6. SERDES SMA

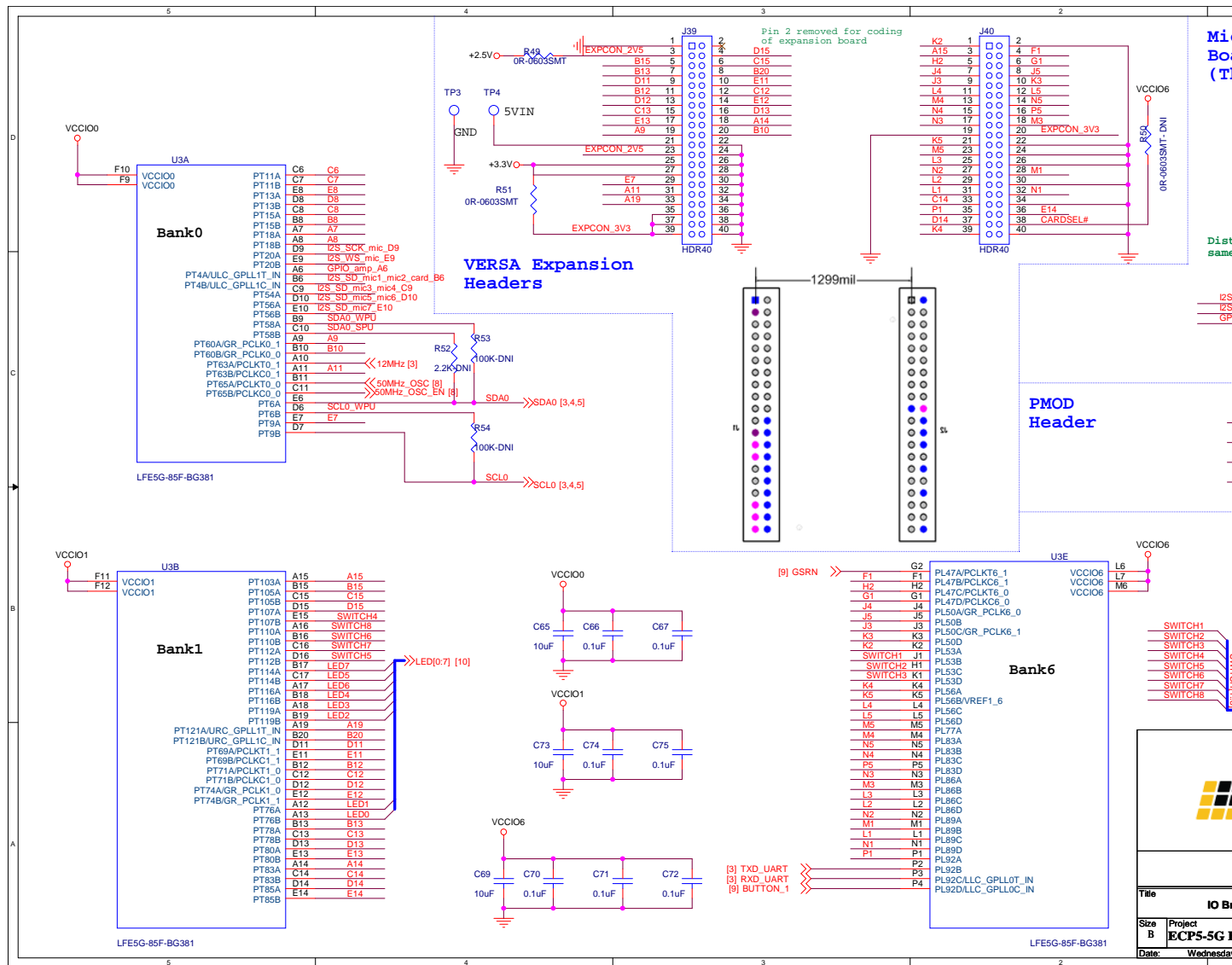

Figure A. 7. IO Breakout (BANK0, BANK1, BANK6)



# ECP5™ Evaluation Board User Guide

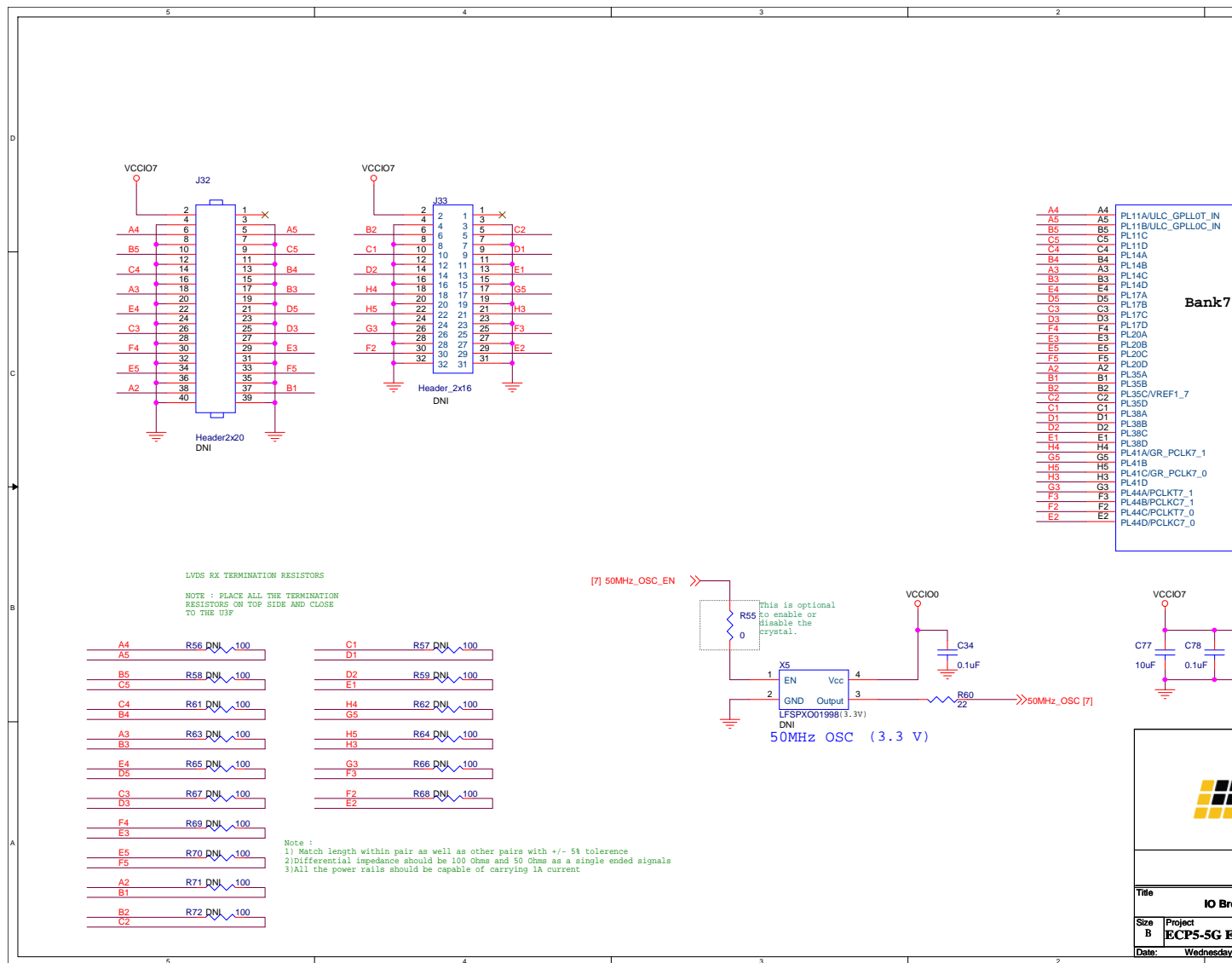

Figure A. 8. IO Breakout (BANK7, Differential Pairs)

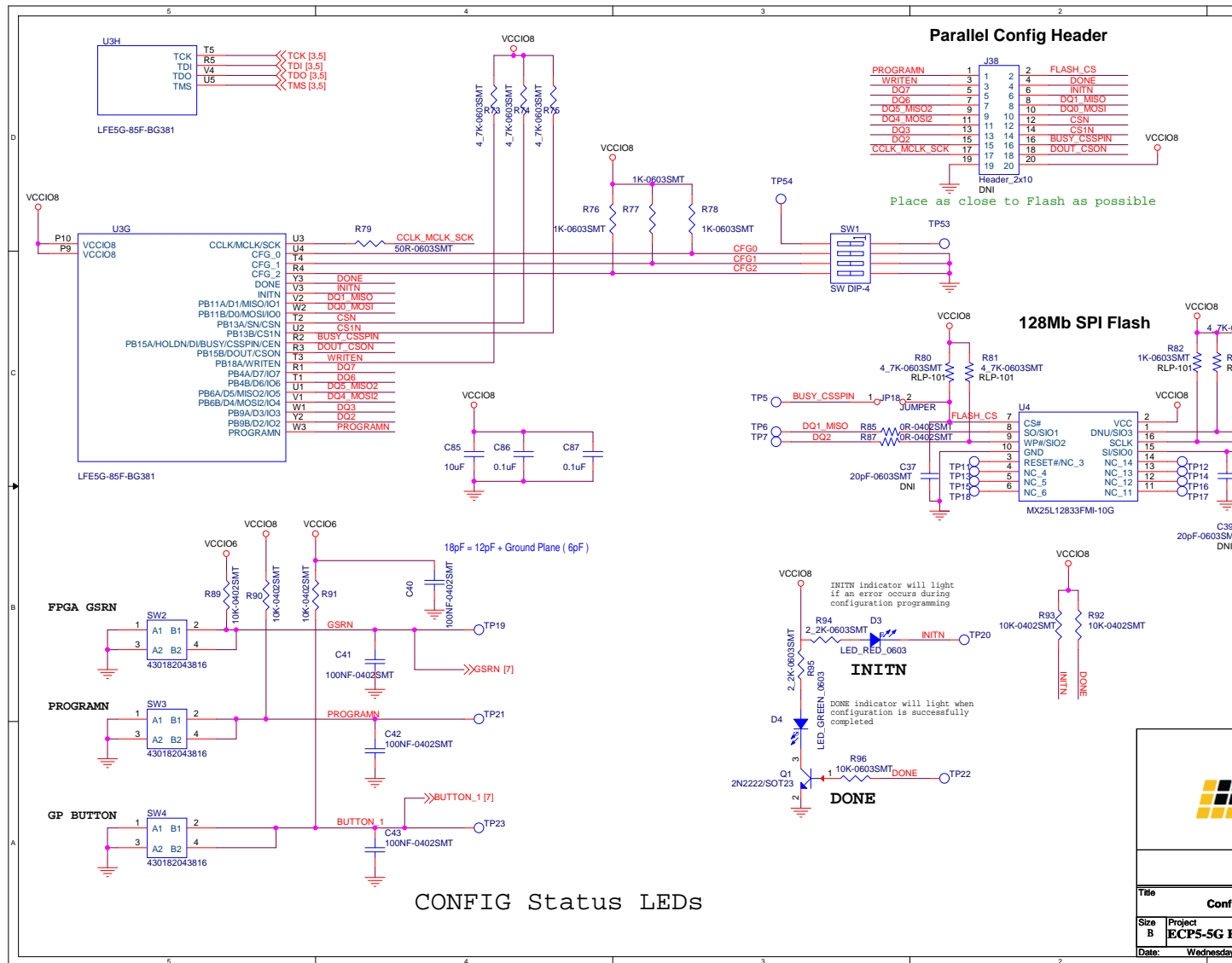

Figure A. 9. Configuration

ECP5™ Evaluation Board  
User Guide

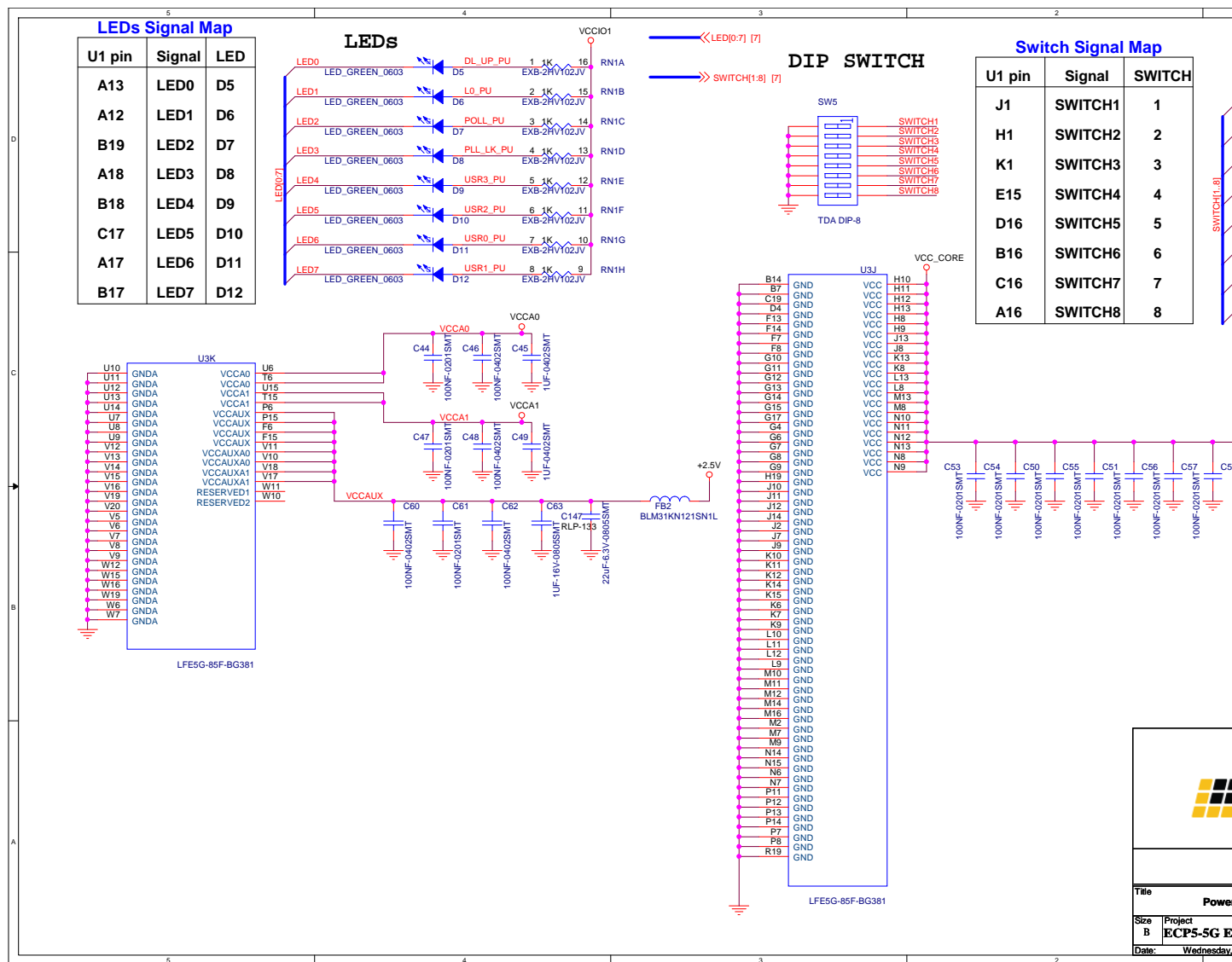

Figure A. 10. Power Decoupling and LEDs

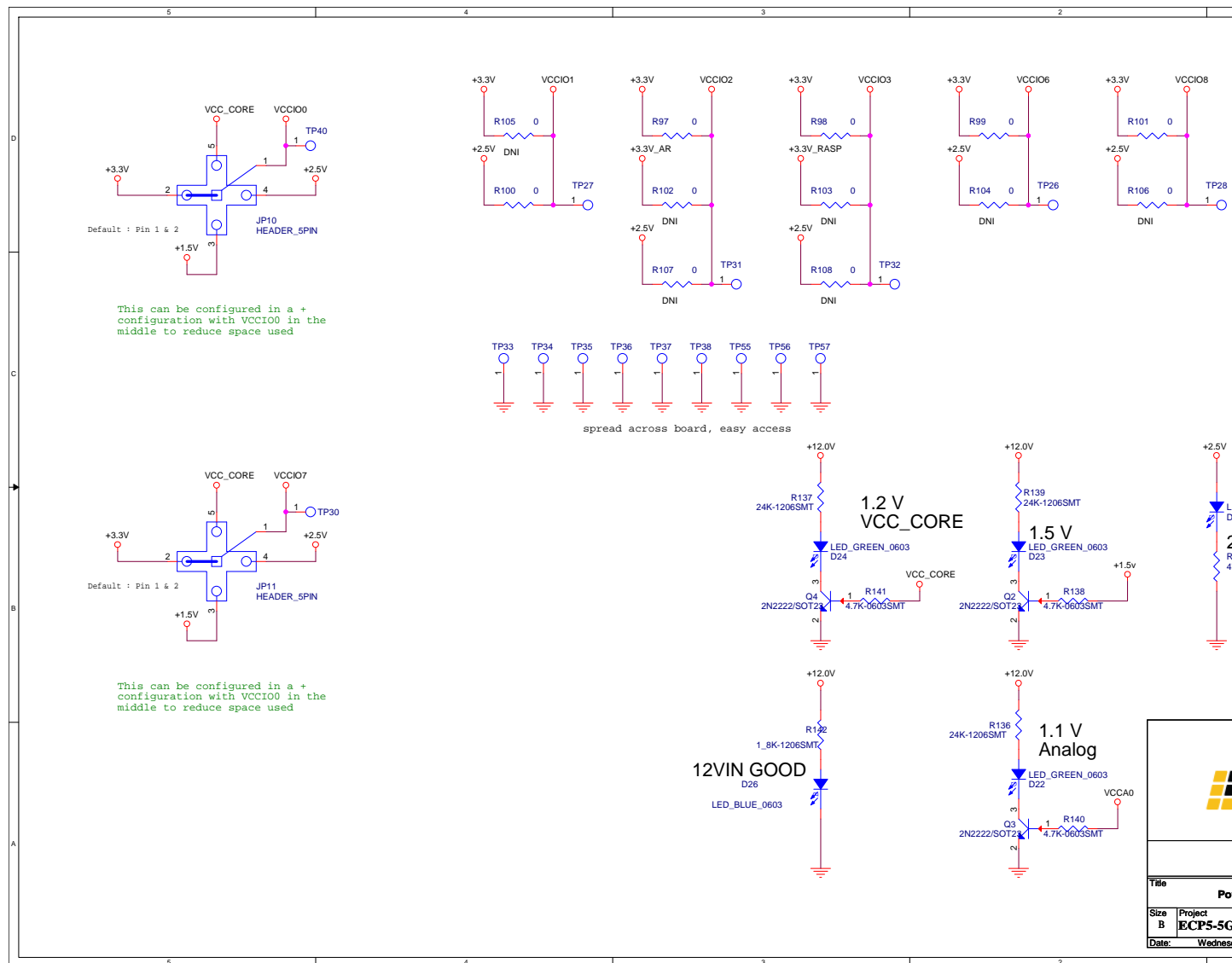

Figure A. 11. Power Hookup

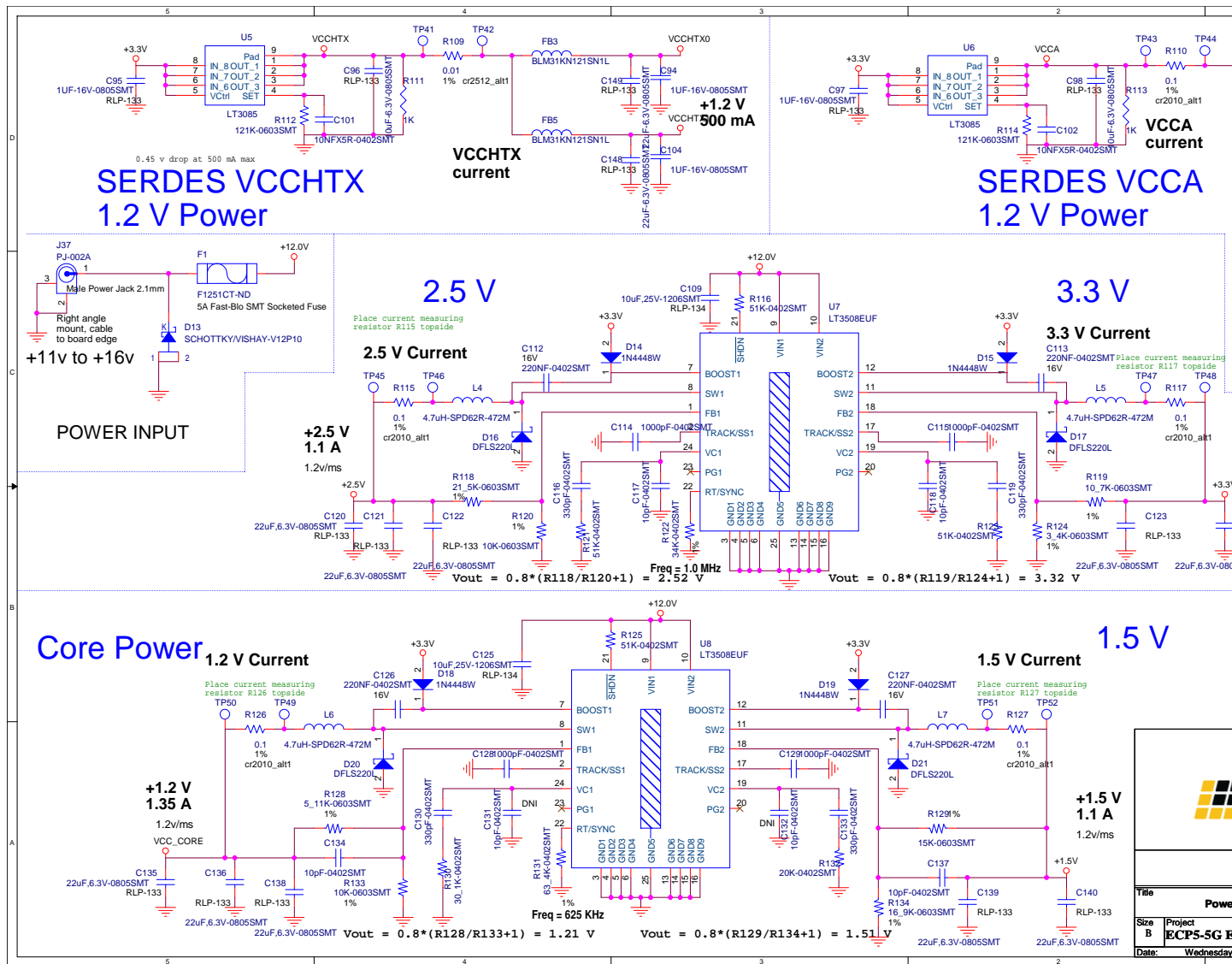

Figure A. 12. Power Regulators

## Appendix B. ECP5 Evaluation Board Bill of Materials

Item	Reference	Qty	Part	PCB Footprint	Comments	Part Number	Manufacturer	Description
1	AG1,AF1,AE1,AD1,AC1,AB1,AA1,AG2,AF2,AE2,AD2,AC2,AB2,AA2,AG3,AF3,AE3,AD3,AC3,AB3,AA3,AG4,AF4,AE4,AD4,AC4,AB4,AA4,AG5,AF5,AE5,AD5,AC5,AB5,AA5,AG6,AF6,AE6,AD6,AC6,AB6,AA6,AG7,AF7,AE7,AD7,AC7,AB7,AA7,AG8,AF8,AE8,AD8,AC8,AB8,AA8,AG9,AF9,AE9,AD9,AC9,AB9,AA9,AG10,AF10,AE10,AD10,AC10,AB10,AA10,AG11,AF11,AE11,AD11,AC11,AB11,AA11	77	T POINT R	TP	DNL	—	—	—
2	C1,C2,C3,C4,C7,C8,C10,C13,C14,C141,C142	11	0.1uF	C0402	—	CL05B104KA5NNNC	Samsung	CAP CER 0.1UF 25V 10% X7R 0402
3	C5	1	10uF	C0402	—	CL05A106MP8NUB8	Samsung	CAP CER 10UF 10V X5R 0402
4	C6,C9	2	4.7uF	C0603	—	CL10A475KA8NQNC	Samsung	CAP CER 4.7UF 25V X5R 0603
5	C11	1	0.01uF	C0402	—	CL05B103KA5NNNC	Samsung	CAP CER 10000PF 25V X7R 0402
6	C12	1	10uF	C0603	—	CL10A106KO8NNNC	Samsung	CAP CER 10UF 10V X5R 0603
7	C15,C16	2	18pF	C0402	—	CL05C180JA5NNNC	Samsung	CAP CER 18PF 25V 10% NP0 0402
8	C17,C18	2	0.1uF	C0402	—	CL05B104KA5NNNC	Samsung	CAP CER 0.1UF 25V 10% X7R 0402
9	C19,C20,C25,C26,C28,C29,C32,C40,C41,C42,C43,C46,C48,C60,C62	15	100NF-0402SMT	RLP-130-A	—	CL05B104KA5NNNC	Samsung	CAP CER 0.1UF 25V 10% X7R 0402
10	C21,C22,C23,C24,C27,C30,C44,C47,C50,C51,C52,C53,C54,C55,C56,C57,C58,C59,C61	19	100NF-0201SMT	C0201	—	C0603X5R1C104K030BC	TDK	CAP CER 0.1UF 16V 10% X5R 0201
11	C31,C63,C94,C95,C97,C100,C104,C106,C108,C111	10	1UF-16V-0805SMT	RLP-133	—	CL21B105KOFNNNG	Samsung	CAP CER 1UF 16V X7R 0805
12	C33	1	0.1uF	cc0402	—	CL05B104KA5NNNC	Samsung	CAP CER 0.1UF 25V 10% X7R 0402
13	C34	1	0.1uF	cc0402	—	CL05B104KA5NNNC	Samsung	CAP CER 0.1UF 25V 10% X7R 0402
14	C35	1	10NF-0402SMT	RLP-130-A	—	CL05B103KA5NNNC	Samsung	CAP CER 10000PF 25V X7R 0402
15	C36	1	100NFX5R-0402SMT	RLP-130-A	—	CL05A104MP5NNNC	Samsung	CAP CER 0.1UF 10V X5R 0402
16	C37,C38,C39	3	20pF-0603SMT	RLP-132	DNL	—	—	—
17	C45,C49	2	1UF-0402SMT	RLP-130-A	—	GRM152R60J105ME15D	Murata	CAP CER 1UF 6.3V X5R 0402
18	C65,C68,C69,C73,C76,C77,C81,C85,C89	9	10uF	C0603	—	LMK107BJ106MALTD	Taiyo Yuden	CAP CER 10UF 10V X5R 20% 0603

Item	Reference	Qty	Part	PCB Footprint	Comments	Part Number	Manufacturer	Description
19	C66,C67,C70,C71,C72,C74,C75,C78,C79,C80,C82,C83,C84,C86,C87,C90,C91,C92	18	0.1uF	C0201	—	C0603X5R1C104K030BC	TDK	CAP CER 0.1UF 16V 10% X5R 0201
20	C96,C98	2	10uF-6.3V-0805SMT	RLP-133	—	CL21A106KPFNNNE	Samsung	CAP CER 10UF 10V X5R 0805
21	C101,C102	2	10NFX5R-0402SMT	RLP-130-A	—	GRM155R61C103KA01D	Murata	CAP CER 10000PF 16V X5R 0402
22	C109,C125	2	10uF,25V-1206SMT	RLP-134	—	TMK316B7106KL-TD	Taiyo Yuden	CAP CER 10UF 25V X7R 1206
23	C112,C113,C126,C127	4	220NF-0402SMT	RLP-130-A	—	CL05A224KO5NNNC	Samsung	CAP CER 0.22UF 16V X5R 0402
24	C114,C115,C128,C129	4	1000pF-0402SMT	RLP-130-A	—	CL05B102KB5NFNC	Samsung	CAP CER 1000PF 50V X7R 0402
25	C116,C119,C130,C133	4	330pF-0402SMT	RLP-130-A	—	CL05B331KB5NNNC	Samsung	CAP CER 330PF 50V X7R 0402
26	C117,C118,C134,C137	4	10pF-0402SMT	RLP-130-A	—	CL05C100CB5NNNC	Samsung	CAP CER 10PF 50V COG/NP0 0402
27	C120,C121,C122,C123,C124,C135,C136,C138,C139,C140	10	22uF,6.3V-0805SMT	RLP-133	—	CL21A226MQQNNNE	Samsung	CAP CER 22UF 6.3V X5R 0805
28	C131,C132	2	10pF-0402SMT	RLP-130-A	DNL	—	—	—
29	C143,C145,C146	3	1UF-16V-0805SMT	RLP-130-A	—	CL21B105KOFNNNG	Samsung	CAP CER 1UF 16V X7R 0805
30	C144	1	1UF-10V-0201SMT	C0201	—	GRM033R61A105ME15D	Murata	CAP CER 1UF 10V X5R 0201
31	C147,C148,C149,C150,C151,C152,C153	7	22uF-6.3V-0805SMT	RLP-133	—	CL21A226MQQNNNE	Samsung	CAP CER 22UF 6.3V X5R 0805
32	D1,D4,D5,D6,D7,D8,D9,D10,D11,D12,D22,D23,D24,D25,D31	15	LED_GREEN_0603	APT1608	—	150060GS75000	Würth	LED GREEN CLEAR 0603 SMD
33	D2	1	ESDR0502N-UDFN6	UDFN6_040	—	ESDR0502NMUTBG	ON semi	TVS DIODE 5.5VWM 6UDFN
34	D3	1	LED_RED_0603	APT1608	—	150060RS75000	Würth	LED RED CLEAR 0603 SMD
35	D13	1	SCHOTTKY/VIS HAY-V12P10	V12P10	—	V12P10-M3/86A	Vishay	DIODE SCHOTTKY 100V 12A TO277A
36	D14,D15,D18,D19	4	1N4448W	1N4448W	—	1N4448WS	On Semi	DIODE GEN PURP 75V 150MA SOD323F
37	D16,D17,D20,D21	4	DFLS220L	DFLS220L	—	DFLS220L-7	Diodes Incorporated	DIODE SCHOTTKY 20V 2A POWERDI123
38	D26	1	LED_BLUE_0603	APT1608	—	150060BS75000	Würth	LED BLUE CLEAR 0603 SMD
39	FB2,FB3,FB4,FB5,FB6,FB7,FB8	7	BLM31KN1215N1L	BLM41P	—	BLM31KN1215N1L	Murata	FERRITE BEAD 120 OHM IMPEDANCE

Item	Reference	Qty	Part	PCB Footprint	Comments	Part Number	Manufacturer	Description
40	F1	1	F1251CT-ND	154010	—	0154010.DR	Littelfuse Inc.	FUSE BRD MNT 10A 125VAC/VDC SMD
41	JP1,JP2,JP3,JP4,JP5,JP6,JP7,JP9,JP18	9	JUMPER	Header_1x2	—	61300211121	Würth	CONN HEADER 2 POS 2.54
42	JP8	1	Receptacle 20X2	HDR254-2X20_socket	—	PPTC202LFBN-RC	Sullins	CONN HEADER FEM 40POS .1" DL TIN
43	JP10,JP11	2	HEADER_5PIN	HEADER_5	—	61300511121	Würth	CONN HEADER 5 POS 2.54
44	J1	1	Header 1x8	hdr_amp_87220_8_1x8_100	DNL	22284081	Molex	CONN HEADER 8POS .100 VERT TIN
45	J2	1	USB_MINI_AB	usb2-0-rec-240-0001-9	—	651305142821	Würth	CONN RCPT USB MINI AB R/A SMT
46	J3,J7	2	Header 1x8	CONF1X8-254P_210 4X240X85 OH_TH	—	61300811121	Würth	CONN HEADER 8 POS 2.54
47	J4	1	Header 1x6	CONF1X6-254P_159 6X240X85 OH_TH	—	61300611121	Würth	CONN HEADER 6 POS 2.54
48	J5	1	Header_2x11	Header_2x11	DNL	61302221121	Würth	CONN HEADER VERT DUAL 22POS 2.54
49	J6	1	Header 1x10	CONF1X10-254P_261 2X240X85 OH_TH	—	61301011121	Würth	CONN HEADER 10POS PIN 2.54MM
50	J8	1	Header_2x4	Header_2x4	DNL	61300821121	Würth	CONN HEADER VERT DUAL 8POS 2.54
51	J9,J10,J11,J12,J13,J14,J15,J16,J17,J18,J19,J20,J21,J22,J23,J24,J25,J26	18	SMA	73391-0060	DNL	73391-0060	Molex	CONN SMA RCPT STR 50 OHM PCB
52	J29	1	2x5 HEADER	61301021121	DNL	61301021121	Würth	CONN HEADER 10POS DL PIN 2.54MM
53	J30	1	2x5 HEADER	61301021121	—	61301021121	Würth	CONN HEADER 10POS DL PIN 2.54MM
54	J31	1	PMOD 2x6	skt_sullins_pppc062_2x6_100	DNL	PPPC062LFBN-RC	Sullins	CONN HEADER FMAL 12PS.1" DL GOLD
55	J32	1	Header2x20	hdr_samtec_mtsw_2x20_100	DNL	61304021121	Würth	CONN HEADER VERT 40POS 2.54
56	J33	1	Header_2x16	Header_2x16	DNL	61303221121	Würth	CONN HEADER VERT DUAL 32POS 2.54
57	J37	1	PJ-002A	pj_002a_3p	—	694106301002	Würth	CONN PWR JACK 2X5.5MM SOLDER
58	J38	1	Header_2x10	Header_2x10	DNL	61302021121	Würth	CONN HEADER VERT DUAL 20POS 2.54
59	J39,J40	2	HDR40	HDR-20x2	—	61304021121	Würth	CONN HEADER VERT 40POS 2.54



Item	Reference	Qty	Part	PCB Footprint	Comments	Part Number	Manufacturer	Description
60	L1,L2,L3,L8	4	600ohm 500mA	fb0603	—	BLM18AG601SN1D	Murata	FERRITE CHIP 600 OHM 500MA 0603
61	L4,L5,L6,L7	4	4.7uH-SPD62R- 472M	SPD62R	—	SPD62R-472M	API Delevan Inc.	FIXED IND 4.7UH 2A 150 MOHM SMD
62	Q1,Q2,Q3,Q4	4	2N2222/SOT23	MMBT222 2ALT-1	—	MMBT2222ALT1G	ON Semiconductor	TRANS NPN 40V 0.6A SOT23
63	RN1	1	EXB-2HV102JV	EXB-2HV	—	EXB-2HV102JV	Panasonic	RES ARRAY 8 RES 1K OHM 1506
64	RN2	1	EXB2HV472JV	EXB-2HV	—	EXB2HV472JV	Panasonic	RES ARRAY 8 RES 4.7K OHM 1506
65	R1,R2,R3	3	4.7K	R0603	—	RC0603FR-074K7L	yageo	RES 4.70K OHM 1/10W 1% 0603 SMD
66	R4,R6	2	0	R0402	—	RC0402FR-070RL	yageo	RES SMD 0 OHM JUMPER 1/16W 0402
67	R5,R12	2	2.2K	R0603	—	RC0603FR-072K2L	yageo	RES SMD 2.2K OHM 1% 1/10W 0603
68	R7,R8,R9,R11,R22,R23,R 24	7	0	R0603	—	RC0603FR-070RL	yageo	RES SMD 0 OHM JUMPER 1/10W 0603
69	R10	1	100K	R0603	—	RC0603FR-07100KL	yageo	RES SMD 100K OHM 1% 1/10W 0603
70	R13,R14,R15	3	10K	R0603	—	RC0603FR-0710KL	Yageo	RES SMD 10K OHM 1% 1/10W 0603
71	R16,R20	2	12K	R0603	—	RC0603FR-0712KL	yageo	RES SMD 12K OHM 1/10W 1% 0603
72	R17,R18,R19,R94,R95,R 135	6	2_2K-0603SMT	RLP-101	—	RC0603FR-072K2L	yageo	RES SMD 2.2K OHM 1% 1/10W 0603
73	R21	1	0R-0603SMT- DNI	RLP-101	DNL	—	—	—
74	R25,R26,R27,R34,R35	5	0	R0603	DNL	RC0603FR-070RL	yageo	RES SMD 0 OHM JUMPER 1/10W 0603
75	R28,R29,R30,R31,R56,R 57,R58,R59,R61,R62,R6 3,R64,R65,R66,R67,R68, R69,R70,R71,R72	20	100	cr0201	DNL	RC0201JR-07100RL	Yageo	RES SMD 100 OHM 5% 1/20W 0201
76	R32,R33,R38,R39,R40,R 41	6	0	R0603	DNL	RC0603JR-070RL	Yageo	RES 0.0 OHM 1/10W JUMP 0603 SMD
77	R44,R89,R90,R91,R92,R 93	6	10K-0402SMT	RLP-100	—	RC0402FR-0710KL	Yageo	RES SMD 10K OHM 1% 1/16W 0402
78	R45,R46	2	10	R0603	—	RC0603FR-0710RL	yageo	RES SMD 10 OHM 1% 1/10W 0603
79	R60	1	22	R0603	—	RC0603FR-0722RL	yageo	RES SMD 22 OHM 1% 1/10W 0603
80	R49,R51	2	0R-0603SMT	RLP-101	—	RC0603FR-070RL	yageo	RES SMD 0 OHM JUMPER 1/10W 0603
81	R50	1	0R-0603SMT- DNI	RLP-101	DNL	—	—	—
82	R52	1	2.2K-DNI	R0603	DNL	RC0603FR-072K2L	yageo	RES SMD 2.2K OHM 1% 1/10W 0603
83	R53,R54	2	100K-DNI	R0603	DNL	RC0603FR-07100KL	yageo	RES SMD 100K OHM 1% 1/10W 0603
84	R55	1	0	cr0603	—	RC0603FR-070RL	yageo	RES SMD 0 OHM JUMPER 1/10W 0603
85	R73,R74,R75,R80,R81,R 83	6	4_7K-0603SMT	RLP-101	—	RC0603FR-074K7L	yageo	RES 4.70K OHM 1/10W 1% 0603 SMD

Item	Reference	Qty	Part	PCB Footprint	Comments	Part Number	Manufacturer	Description
86	R76,R77,R78,R82	4	1K-0603SMT	RLP-101	—	RC0603FR-071KL	yageo	RES SMD 1K OHM 1/10W 1% 0603
87	R79	1	50R-0603SMT	RLP-101	—	RC0603FR-0749R9L	yageo	RES SMD 49.9 OHM 1% 1/10W 0603
88	R85,R86,R87,R88	4	0R-0402SMT	RLP-100	—	RC0402FR-070RL	yageo	RES SMD 0 OHM JUMPER 1/16W 0402
89	R94	1	2_2K-0603SMT	RLP-101	—	RC0603FR-072K2L	yageo	RES SMD 2.2K OHM 1% 1/10W 0603
90	R95,R135	2	2_2K-0603SMT	RLP-101	—	RC0603FR-072K2L	yageo	RES SMD 2.2K OHM 1% 1/10W 0603
91	R96,R120,R133	3	10K-0603SMT	RLP-101	—	RC0603FR-0710KL	Yageo	RES SMD 10K OHM 1% 1/10W 0603
92	R97,R98,R99,R100,R101	5	0	R0603	—	RC0603JR-070RL	Yageo	RES SMD 0 OHM JUMPER 1/10W 0603
93	R102,R103,R104,R105,R106,R107,R108	7	0	R0603	DNL	RC0603JR-070RL	Yageo	RES SMD 0 OHM JUMPER 1/10W 0603
94	R109	1	0.01	cr2512_alt 1	—	PE2512FKE7W0R01L	Yageo	RES 0.01 OHM 1% 2W 2512
95	R110,R115,R117,R126,R127	5	0.1	cr2010_alt 1	—	WSL2010R1000FEA	Vishay Dale	RES 0.1 OHM 1% 1/2W 2010
96	R111,R113	2	1K	R0603	—	RC0603FR-071KL	yageo	RES SMD 1K OHM 1/10W 1% 0603
97	R112,R114	2	121K-0603SMT	RLP-101	—	RC0603FR-07121KL	yageo	RES SMD 121K OHM 1% 1/10W 0603
98	R116,R121,R123,R125	4	51K-0402SMT	RLP-100	—	RC0402FR-0751KL	yageo	RES SMD 51K OHM 1% 1/16W 0402
99	R118	1	21_5K-0603SMT	RLP-101	—	RC0603FR-0721K5L	yageo	RES SMD 21.5K OHM 1% 1/10W 0603
100	R119	1	10_7K-0603SMT	RLP-101	—	RC0603FR-0710K7L	yageo	RES SMD 10.7K OHM 1% 1/10W 0603
101	R122	1	34K-0402SMT	RLP-100	—	RC0402FR-0734KL	yageo	RES SMD 34K OHM 1% 1/16W 0402
102	R124	1	3_4K-0603SMT	RLP-101	—	RC0603FR-073K4L	yageo	RES SMD 3.4K OHM 1% 1/10W 0603
103	R128	1	5_11K-0603SMT	RLP-101	—	RC0603FR-075K11L	yageo	RES SMD 5.11K OHM 1% 1/10W 0603
104	R129	1	15K-0603SMT	RLP-101	—	RC0603FR-0715KL	yageo	RES SMD 15K OHM 1% 1/10W 0603
105	R130	1	30_1K-0402SMT	RLP-100	—	ERJ-2RKF3012X	Panasonic	RES SMD 30.1K OHM 1% 1/10W 0402
106	R131	1	63_4K-0402SMT	RLP-100	—	ERJ-2RKF6342X	Panasonic	RES SMD 63.4K OHM 1% 1/10W 0402
107	R132	1	20K-0402SMT	RLP-100	—	ERJ-2RKF2002X	Panasonic	RES SMD 20K OHM 1% 1/10W 0402
108	R134	1	16_9K-0603SMT	RLP-101	—	RC0603FR-0716K9L	yageo	RES SMD 16.9K OHM 1% 1/10W 0603
109	R136,R137,R139	3	24K-1206SMT	RLP-103	-	RC1206JR-0724KL	Panasonic	RES SMD 24K OHM 5% 1/4W 1206
110	R138,R140,R141	3	4.7K-0603SMT	RLP-101	—	RC0603FR-074K7L	yageo	RES SMD 4.7K OHM 1% 1/10W 0603
111	R142	1	1_8K-1206SMT	RLP-103	-	RC1206JR-071K8L	Yageo	RES SMD 1.8K OHM 5% 1/4W 1206
112	R179	1	470R-0603SMT	RLP-101	-	RC0603FR-07470RL	yageo	RES SMD 470 OHM 1% 1/10W 0603
113	R180	1	100	R0402	—	ERJ-2RKF1000X	Panasonic	RES SMD 100 OHM 1% 1/10W 0402
114	SW1	1	SW DIP-4	41812127 0804	—	418121270804	Würth	SWITCH SLIDE DIP SPST 25MA 24V

Item	Reference	Qty	Part	PCB Footprint	Comments	Part Number	Manufacturer	Description
115	SW2,SW3,SW4	3	430182043816	sw_sp_st_ck_pts645_sm	—	430182043816	Wurth	SWITCH TACTILE SPST-NO 0.05A 12V
116	SW5	1	TDA DIP-8	TDA08HOS B1	—	416131160808	Wurth	SWITCH SLIDE DIP SPST 25MA 24V
117	TP1,TP2,TP24,TP25,TP26,TP27,TP28,TP29,TP30,TP31,TP32,TP33,TP34,TP35,TP36,TP37,TP38,TP39,TP40,TP55,TP56,TP57	22	TP_S_40_63	TP	DNL	—	—	Square test point, 40mil inner diameter, 63mil outer diameter
118	TP3,TP4,TP5,TP6,TP7,TP8,TP9,TP10,TP11,TP12,TP13,TP14,TP15,TP16,TP17,TP18,TP19,TP20,TP21,TP22,TP23,TP41,TP42,TP43,TP44,TP45,TP46,TP47,TP48,TP49,TP50,TP51,TP52,TP53,TP54	35	TestPoint	TP50	DNL	—	—	—
119	U1	1	FT2232HL	tqfp64_0p5_12p2x12p2_h1p6	—	FT2232HL-REEL	FTDI	IC USB HS DUAL UART/FIFO 64-LQFP
120	U2	1	93LC56C-I/SN	so8_50_244	—	93LC56C-I/SN	Microchip Technology	IC EEPROM 2KBIT 3MHZ 8SOIC
121	U3	1	LFESG-85F-BG381	LFESG-85F-BG381	—	LFESUM5G-85F-8BG381	Lattice	83.6K LUTS, 205 /O, 1.1V, -8 SPE
122	U4	1	MX25L12833F MI-10G	SO16W	—	MX25L12833FMI-10G	Macronix International	IC FLASH 128MBIT 133MHZ 16SOIC
123	U5,U6	2	LT3085	msop8_26_198_ep	—	LT3085IMS8E#PBF	Linear Technology/Analog Devices	IC REG LIN POS ADJ 500MA 8MSOP
124	U7,U8	2	LT3508EUF	LT3508EUF	—	LT3508EUF#PBF	Linear Technology/Analog Devices	IC REG BUCK ADJ 1.4A DL 24QFN
125	X1	1	7M-12.000MAAJ	xtal_4p_7m	—	7M-12.000MAAJ-T	TXC	CRYSTAL 12MHZ 18PF SMD
126	X2	1	200_00MHz_LVDS	DSC1123AE2	—	DSC1123AE2-200.0000	Microchip Technology	OSC MEMS 200.000MHZ LVDS SMD
127	X5	1	LFSPX001998	osc_4p_cb3lv	DNL	LFSPX0019987Reel	IQD	OSC XO 50.000MHZ HCMOS TTL SMD
128	Shorting-Jumper	4	Shorting-Jumper	—	—	929957-08	3M	SHORTING JUMPERS GOLD PLATED GRY
129	ECP5 EVALUATION BOARD REV A PCB	1	—	—	—	305-PD-18-0078	PACTRON	—

## Revision History

### Revision 1.0, July 2018

Initial release.



7<sup>th</sup> Floor, 111 SW 5<sup>th</sup> Avenue  
Portland, OR 97204, USA  
T 503.268.8000  
[www.latticesemi.com](http://www.latticesemi.com)

## X-ON Electronics

Largest Supplier of Electrical and Electronic Components

*Click to view similar products for [Programmable Logic IC Development Tools](#) category:*

*Click to view products by [Lattice](#) manufacturer:*

Other Similar products are found below :

[HLDC-DDR3-A](#) [DK-DEV-5SGXEA7N](#) [EK-10M50F484](#) [EPXA4F672C2](#) [EPXA4F672C3](#) [EPXA4F672C1](#) [K0161](#) [LCMXO256C-S-EVN](#)  
[12GSDIFMCCD](#) [SFP+X4FMCCD](#) [88980182](#) [P0582](#) [HW-PWAC-2600317](#) [DEV-17514](#) [LCMXO3D-9400HC-B-EVN](#) [P0671](#) [DK-K7-](#)  
[CONN-G](#) [P0467](#) [LCMXO2-1200ZE-P1-EVN](#) [LCMXO2-4000HE-DSIB-EVN](#) [DK-DEV-4SGX530N](#) [LCMXO3L-SMA-EVN](#) [P006-006-2](#)  
[EK-U1-VCU108-G](#) [A2F500-DEV-KIT-2](#) [LCMXO3LF-9400C-ASC-B-EVN](#) [471-014](#) [EVAL-TPG-ZYNQ3](#) [SL001](#) [80-001005](#) [P0466-EDU](#)  
[EK-10CL025U256](#) [P0496](#) [P0493](#) [DK-SOC-10AS066S-A](#) [DK-DEV-10CX220-A](#) [80-001002](#) [iCE40UP5K-MDP-EVN](#) [RXCA10S066PF34-](#)  
[IDK00A](#) [ALTSODIAC5ST](#) [ALTHYDRAC5GX](#) [ALTNITROC5GX](#) [ALTBERYLLC5GX](#) [471-015](#) [LFE3-17EA-USB3-EVN](#) [1553](#) [4332](#) [Hinj](#)  
[HinjKit](#) [SNOMAKRKIT](#)