



SiI9125 HDMI Receiver with Deep Color Outputs

Data Brief

Document # SiI-DB-0205-C03

September 2010

Copyright Notice

Copyright © 2009-2010 Silicon Image, Inc. All rights reserved. These materials contain proprietary and confidential information (including trade secrets, copyright and other interests) of Silicon Image, Inc. You may not use these materials except only for your bona fide non-commercial evaluation of your potential purchase of products and/or services from Silicon Image or its affiliates, and/or only in connection with your purchase of products and/or services from Silicon Image or its affiliates, and only in accordance with the terms and conditions herein. You have no right to copy, modify, transfer, sublicense, publicly display, create derivative works of or distribute these materials, or otherwise make these materials available, in whole or in part, to any third party.

Trademark Acknowledgment

Silicon Image™, VastLane™, SteelVine™, PinnaClear™, Simplay™, Simplay HD™, Satalink™, InstaPort™, LiquidHD™, and TMDS™ are trademarks or registered trademarks of Silicon Image, Inc. in the United States and other countries. HDMI®, the HDMI logo and High-Definition Multimedia Interface™ are trademarks or registered trademarks of, and are used under license from, HDMI Licensing, LLC. x.v.Color™ is a trademark of Sony Corporation

Export Controlled Document

This document contains information subject to the Export Administration Regulations (EAR) and has a classification of EAR99 or is controlled for Anti-Terrorism (AT) purposes. Transfer of this information by any means to an EAR Country Group E:1 or foreign national thereof (whether in the U.S. or abroad) may require an export license or other approval from the U.S. Department of Commerce. For more information, contact the Silicon Image Director of Global Trade Compliance.

Further Information

To request other materials, detailed hardware and software guides, and additional information, contact your local Silicon Image, Inc. sales office or visit the Silicon Image, Inc. web site at www.siliconimage.com. Information about obtaining licenses required for using HDMI and HDCP technologies is available from www.hdmi.org and www.digital-cp.com.

© 2009-2010 Silicon Image, Inc. All rights reserved

Introduction

The SiI9125 HDMI Receiver with Deep Color Outputs is a second-generation dual-input High Definition Multimedia Interface (HDMI[®]), HDCP, and DVI compliant receiver. It is software-compatible with the SiI9133 receiver with Deep Color outputs as well as the SiI9033 receiver. Digital televisions that can display 10- or 12-bit color depth can now provide the highest quality protected digital audio and video over a single cable. The SiI9125 device can receive Deep Color video up to 12-bit, 1080p @ 60 Hz. Backward compatibility with the DVI 1.0 specification allows HDMI systems to connect to existing DVI 1.0 hosts, such as HD set-top boxes and PCs.

The latest generation Integrated Transition Minimized Differential Signaling[™] (TMDS[™]) core runs at 25–225 MHz and passes all HDMI compliance tests.

The SiI9125 receiver is pre-programmed with High-bandwidth Digital Content Protection (HDCP) keys and contains an integrated HDCP decryption engine for receiving protected audio and video content. This set of keys helps reduce programming overhead, lowers manufacturing costs, and provides the highest level of security.

The specialized audio and video processing contained in the receiver can add HDMI capability to earlier-generation consumer electronics. Efficient color space conversion receives RGB video data and delivers either standard-definition or high-definition YCbCr formats.

This receiver supports high end audio systems. An industry standard I²S port allows direct connection to low cost audio DACs at up to 192 kHz. Audio down-sampling allows the device to share the audio bus with a high-sample-rate audio DAC while down-sampling audio for an attached display supporting only lower rates.

The device provides flexible power management.

Digital Video Interface

- automatic video mode configuration simplifies firmware design
- 36-bit RGB/YCbCr 4:4:4
- 16/20/24-bit YCbCr 4:2:2
- 8/10/12-bit YCbCr 4:2:2 (ITU BT.656)
- 12/15/18-bit Digital Multimedia Output (DMO) RGB/YCbCr 4:4:4 (clocked with rising and falling edges)
- color space conversion for both RGB-to-YCbCr and YCbCr to RGB (both 601 and 709)
- true 12-bit accurate data using 14-bit processing

Digital Audio Interface

- sends and receives 2-channel digital audio up to 192 KHz
- I²S output supports up to 2-channel 192 kHz digital audio
- The S/PDIF port supports 192 kHz compressed streams
- S/PDIF output supports PCM, Dolby Digital, and DTS
- IEC60958 or IEC61937 compatible
- 2:1 and 4:1 down-sampling to handle 96 kHz and 192 kHz audio streams

Package

- 20 mm x 20 mm 144-pin TQFP package with an ePad[™]

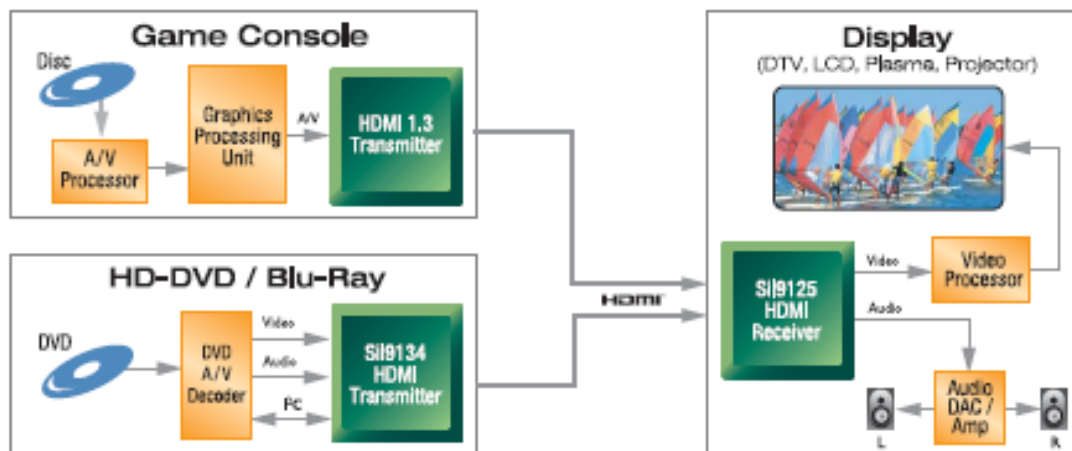

Figure 1. Typical Application

Comparing SiI9125 with SiI9133 and SiI9023

Table 1 summarizes the functional differences among the SiI9023/9025, the SiI9133, and the SiI9125 receivers.

Table 1. Summary of New Features

Feature	SiI9023/9025	SiI9133	SiI9125
HDMI Input Connections			
TMDS Input Ports	2	2	2
Color Depth	8-bit	8/10/12-bit	8/10/12-bit
DDC Input Ports	2	2	2
Maximum TMDS Input Clock	165 MHz	225 MHz	225 MHz
Output Ports			
Digital Video Output Ports	1	1	1
Maximum Output Pixel Clock	165 MHz.	165 MHz.	165 MHz.
Maximum Output Bus Width	24	36	36
Analog Video Output Ports	0	0	0
S/PDIF Output Ports	1	1	1
I²S Output	1	4	1
Video Processing			
Color Space Converter	RGB to/from YCbCr	RGB to/from YCbCr	RGB to/from YCbCr
Pixel Clock Divider	0.25, 0.5	0.25, 0.5	0.25, 0.5
Digital Video Bus Mapping	swap Cb, Cr pins	swap Cb, Cr pins	swap Cb, Cr pins
Maximum Audio Sample Rate (Fs)			
2-channel (I²S or S/PDIF)	192 kHz	192 kHz	192 kHz
8-channel (I²S)	N/A	192 kHz	N/A
High Bit Rate Audio Support Compressed DTS-HD and Dolby True-HD	No	No	No
Other Features			
MCLK Generation	No external connection required.	No external connection required.	No external connection required.
HDCP Repeater Support	No	Not Used	No
Interlaced Format Detection Pin	Yes	Yes	Yes
TMDS R_{EXT_SWING}	Not Used	Not Used	Not Used
Package	144-pin TQFP ePad	404-pin BGA w/Heat Slug	144-pin TQFP ePad

Pin Diagram

Figure 2 shows the SiI9125 pin assignments of the receiver. Pin names are generalized by type for this document. The list below the diagram describes the purpose of each type. The package is a 20 mm x 20 mm 144-pin TQFP with an ePad.

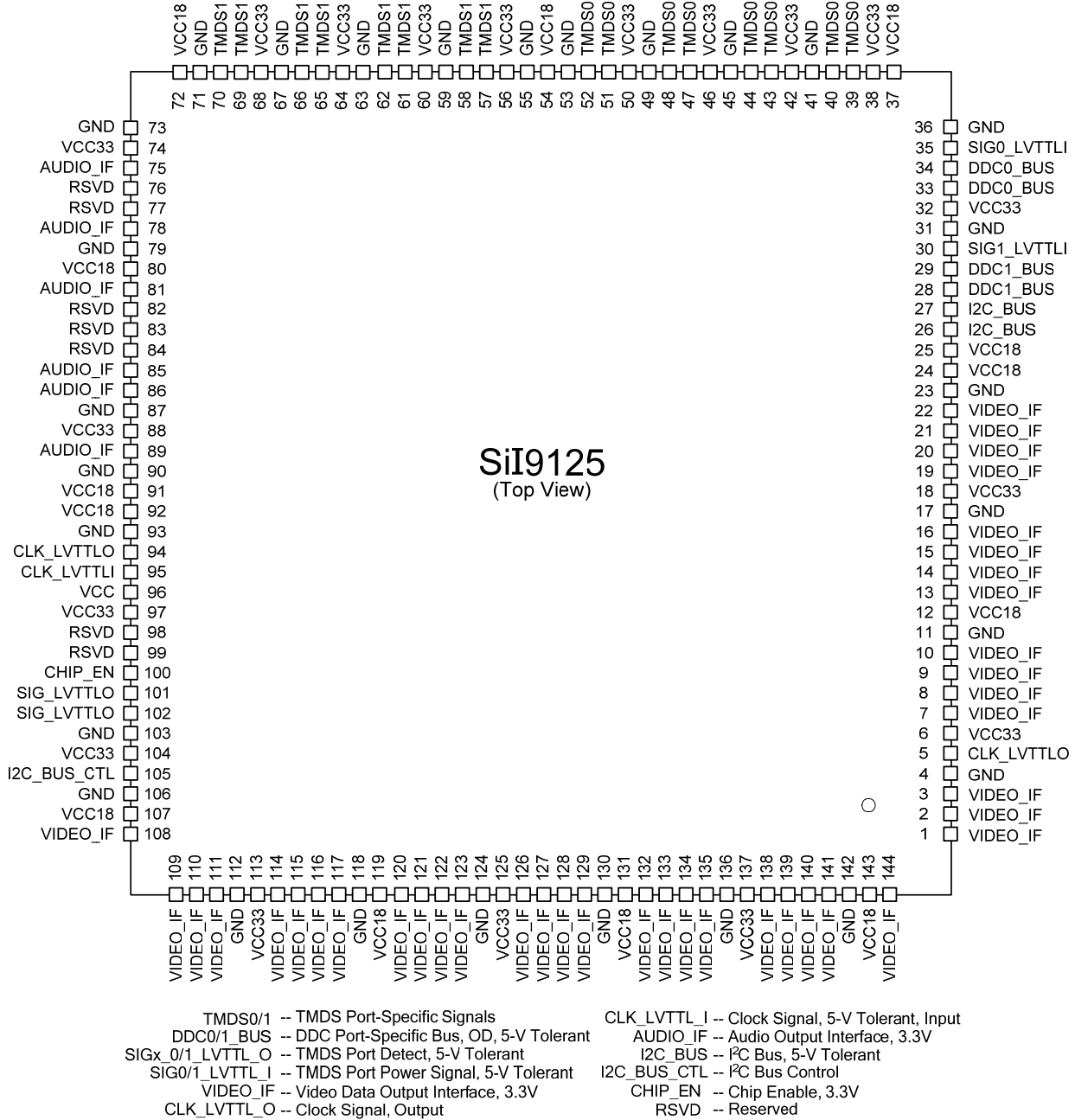
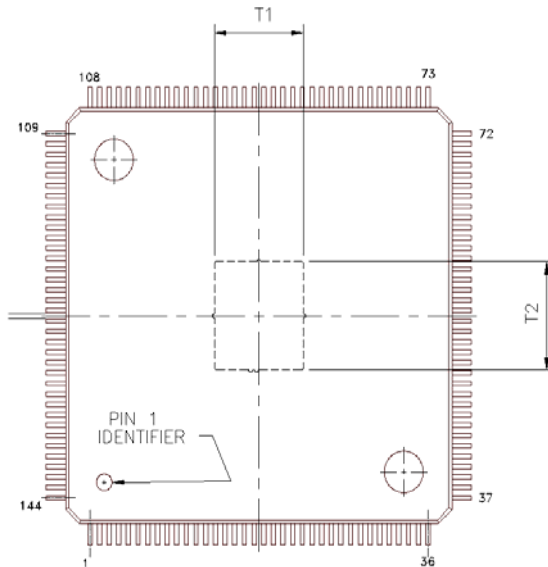

Figure 2. Pin Diagram

Packaging

ePad Enhancement

The SiI9125 receiver is packaged in a 144 pin TQFP package with an ePad™. The ePad dimensions are shown in Figure 3.



ePad Dimensions: Amkor and SPIL

Item	Description	Typ	Max
T1	ePad height	4.60	4.64
T2	ePad width	5.20	5.24

ePad Dimensions: ASE

Item	Description	Typ	Max
T1	ePad height	5.25	5.29
T2	ePad width	5.25	5.29

All dimensions are in millimeters.

The ePad is centered on the package center lines. The measurement tolerance is ± 0.04 mm for all manufacturers. The ePad tab dimensions may vary.

A clearance of at least 0.25 mm should be provided on the PCB between the edge of the ePad and the inner edges of the lead pads to avoid the possibility of electrical shorts.

Silicon Image recommends that the ePad be soldered to the PCB and electrically grounded on the PCB. The ePad must not be connected to any other voltage level.

Figure 3. ePad Diagram

PCB Layout Guidelines

PCB layout designers should refer to Silicon Image application note *PCB Layout Guidelines: Designing with Exposed Pads* (SiI-AN-0129) for basic design guidelines when designing with thermally enhanced packages using the Exposed Pad.

Package Dimensions

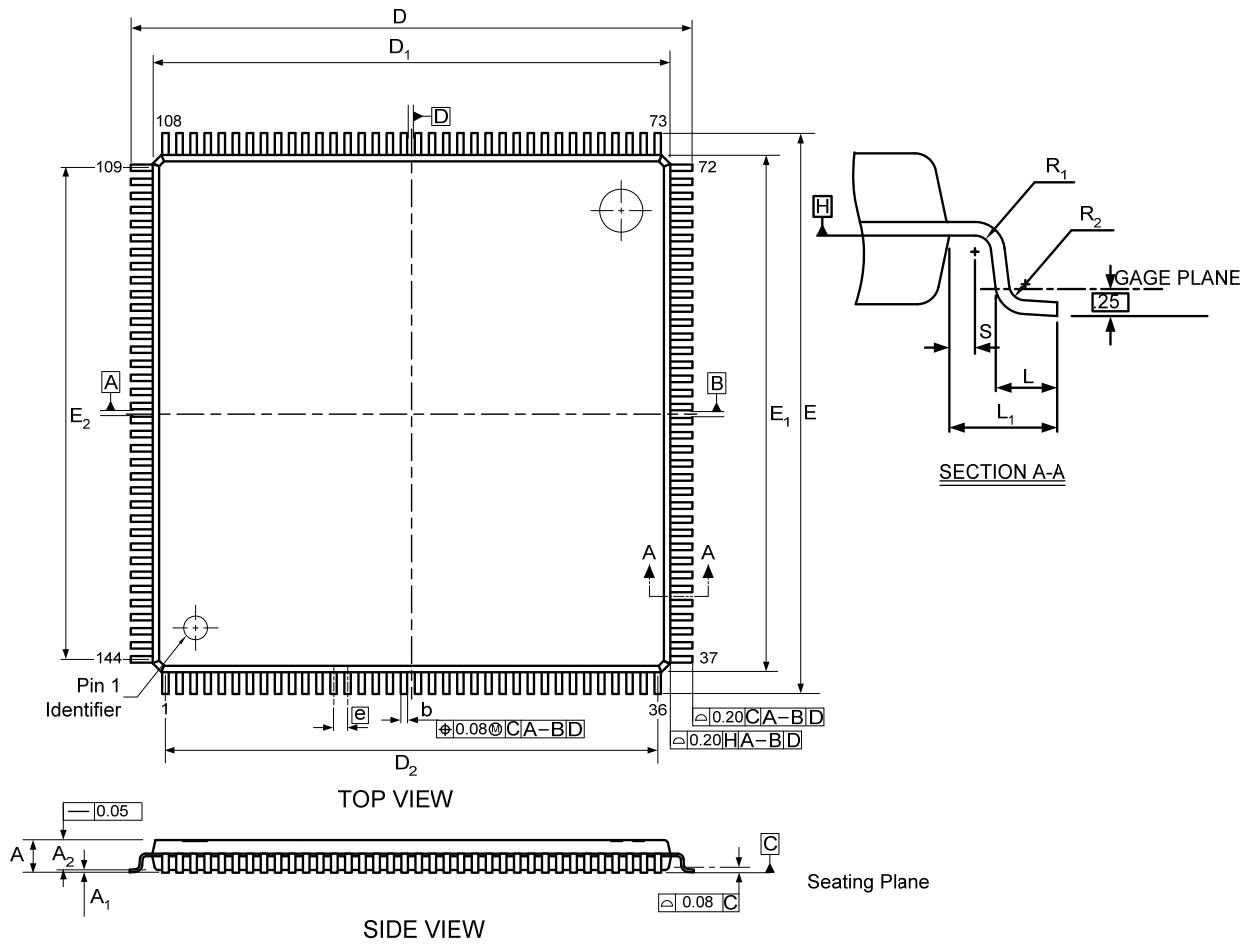

JEDEC Package Code MS-026-AFB

Item	Description	Min	Typ	Max
A	Thickness	1.00	1.10	1.20
A1	Stand-off	0.05	0.10	0.15
A2	Body thickness	0.95	1.00	1.05
D	Footprint	22.00 BSC		
E	Footprint	22.00 BSC		
D ₁	Body size	20.00 BSC		
E ₁	Body size	20.00 BSC		
D ₂	Lead Row Width	17.5 BSC		
E ₂	Lead Row Width	17.5 BSC		

Item	Description	Min	Typ	Max
b	Lead width	0.17	0.22	0.27
C	Lead thickness	0.09	—	0.20
e	Lead pitch	0.50 BSC		
L	Lead foot length	0.45	0.60	0.75
L ₁	Total lead length	1.00 REF		
R ₁	Lead radius, inside	0.08	—	—
R ₂	Lead radius, outside	0.08	—	0.20
S	Lead horizontal run	0.20	—	—

Dimensions in millimeters.

Overall thickness A = A₁ + A₂.

Figure 4. Package Diagram

Marking Specification

Drawing is not to scale and pin count shown is representative. Refer to specifics in [Figure 5](#) on page 5.

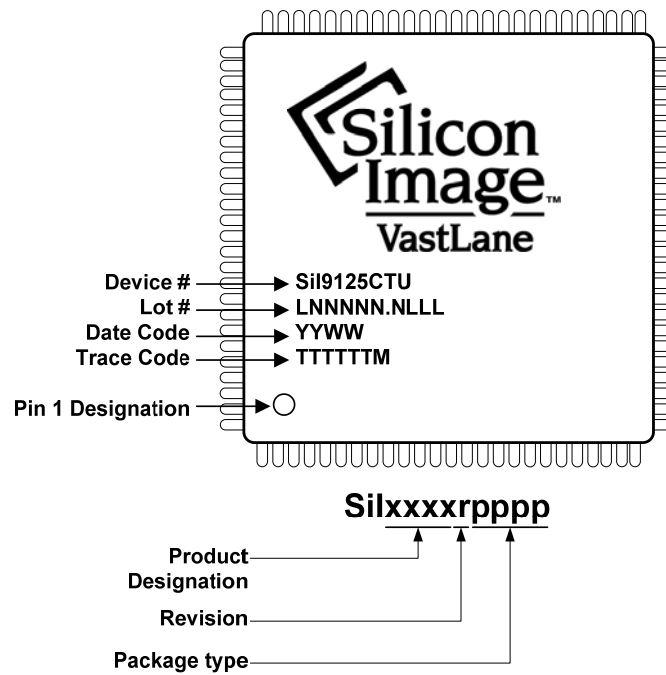

The universal package may be used in lead-free and ordinary process lines.

Figure 5. Marking Diagram

Legend	Description
LNNNNN.NLLL	Lot number
YY	Year of manufacture
WW	Week of manufacture
TTTTTT	Trace code
M	Maturity code

Ordering Information

Production Part Numbers:

TMDS Input Clock Range	Part Number
25–225 MHz	SiI9125CTU

Disclaimers

These materials are provided on an “AS IS” basis. Silicon Image, Inc. and its affiliates disclaim all representations and warranties (express, implied, statutory or otherwise), including but not limited to: (i) all implied warranties of merchantability, fitness for a particular purpose, and/or non-infringement of third party rights; (ii) all warranties arising out of course-of-dealing, usage, and/or trade; and (iii) all warranties that the information or results provided in, or that may be obtained from use of, the materials are accurate, reliable, complete, up-to-date, or produce specific outcomes. Silicon Image, Inc. and its affiliates assume no liability or responsibility for any errors or omissions in these materials, makes no commitment or warranty to correct any such errors or omissions or update or keep current the information contained in these materials, and expressly disclaims all direct, indirect, special, incidental, consequential, reliance and punitive damages, including WITHOUT LIMITATION any loss of profits arising out of your access to, use or interpretation of, or actions taken or not taken based on the content of these materials.

Silicon Image, Inc. and its affiliates reserve the right, without notice, to periodically modify the information in these materials, and to add to, delete, and/or change any of this information.

Notwithstanding the foregoing, these materials shall not, in the absence of authorization under U.S. and local law and regulations, as required, be used by or exported or re-exported to (i) any U.S. sanctioned or embargoed country, or to nationals or residents of such countries; or (ii) any person, entity, organization or other party identified on the U.S. Department of Commerce's Denied Persons or Entity List, the U.S. Department of Treasury's Specially Designated Nationals or Blocked Persons List, or the Department of State's Debarred Parties List, as published and revised from time to time; (iii) any party engaged in nuclear, chemical/biological weapons or missile proliferation activities; or (iv) any party for use in the design, development, or production of rocket systems or unmanned air vehicles.

Products and Services

The products and services described in these materials, and any other information, services, designs, know-how and/or products provided by Silicon Image, Inc. and/or its affiliates are provided on as “AS IS” basis, except to the extent that Silicon Image, Inc. and/or its affiliates provides an applicable written limited warranty in its standard form license agreements, standard Terms and Conditions of Sale and Service or its other applicable standard form agreements, in which case such limited warranty shall apply and shall govern in lieu of all other warranties (express, statutory, or implied). EXCEPT FOR SUCH LIMITED WARRANTY, SILICON IMAGE, INC. AND ITS AFFILIATES DISCLAIM ALL REPRESENTATIONS AND WARRANTIES (EXPRESS, IMPLIED, STATUTORY OR OTHERWISE), REGARDING THE INFORMATION, SERVICES, DESIGNS, KNOW-HOW AND PRODUCTS PROVIDED BY SILICON IMAGE, INC. AND/OR ITS AFFILIATES, INCLUDING BUT NOT LIMITED TO, ALL IMPLIED WARRANTIES OF MERCHANTABILITY, FITNESS FOR A PARTICULAR PURPOSE, AND/OR NON-INFRINGEMENT OF THIRD PARTY RIGHTS. YOU ACKNOWLEDGE AND AGREE THAT SUCH INFORMATION, SERVICES, DESIGNS, KNOW-HOW AND PRODUCTS HAVE NOT BEEN DESIGNED, TESTED, OR MANUFACTURED FOR USE OR RESALE IN SYSTEMS WHERE THE FAILURE, MALFUNCTION, OR ANY INACCURACY OF THESE ITEMS CARRIES A RISK OF DEATH OR SERIOUS BODILY INJURY, INCLUDING, BUT NOT LIMITED TO, USE IN NUCLEAR FACILITIES, AIRCRAFT NAVIGATION OR COMMUNICATION, EMERGENCY SYSTEMS, OR OTHER SYSTEMS WITH A SIMILAR DEGREE OF POTENTIAL HAZARD. NO PERSON IS AUTHORIZED TO MAKE ANY OTHER WARRANTY OR REPRESENTATION CONCERNING THE PERFORMANCE OF THE INFORMATION, PRODUCTS, KNOW-HOW, DESIGNS OR SERVICES OTHER THAN AS PROVIDED IN THESE TERMS AND CONDITIONS.



1060 E. Arques Avenue
Sunnyvale, CA 94085
T 408.616.4000 F 408.830.9530
www.siliconimage.com

X-ON Electronics

Largest Supplier of Electrical and Electronic Components

Click to view similar products for [Audio DSPs](#) category:

Click to view products by [Lattice](#) manufacturer:

Other Similar products are found below :

[E-TDA7377A](#) [TDA7716N](#) [BR281W31A101V1G](#) [LC823425-12G1-LR-H](#) [TDA7419N](#) [R3910-CFAB-E1B](#) [HMC474MP86ETR](#)
[AMIS30660CANH6G](#) [B300W35A102XYG](#) [MAX9892ERT+T](#) [MAX9892ELTT](#) [SB3229-E1](#) [NJW1157BFC2](#) [ZL38060LDG1](#) [SB3231-E1](#)
[HMC1022-SX](#) [SA3229-E1-T](#) [LC75056PE-H](#) [TDA7729](#) [NJW1195AV](#) [WM5102ECS/R](#) [CI1103](#) [WM5102ECS/R](#) [100-CG1820](#) [CS48L10-](#)
[CNZ](#) [CS48L10-CNZR](#) [CS47024C-CQZ](#) [CS48L10-CWZR](#) [CS48L11-CNZ](#) [HMC618LP3ETR](#) [HMC604LP3ETR](#) [HMC5622LS7TR](#)
[HMC288MS8ETR](#) [HMC240A](#) [STA323W13TR](#) [BU9408KS2](#) [DSPB56725AF](#) [TAS3204PAGR](#) [ADAU1467WBCPZ300](#)
[ADAU1463WBCPZ300](#) [BD37514FS-E2](#) [ADAU1463WBCPZ150](#) [ADAU1466WBCPZ300](#) [NJM2294V-TE1](#) [LC823450TA-2H](#) [NJM2537V-](#)
[TE1](#) [TWL1103TPBSQ1](#) [LC823450XDTBG](#) [HMC-AUH312-SX](#) [ADAV4622BSTZ](#)