

### DESCRIPTION

LC1118 is a dual channel low-dropout regulator that delivers a maximum current of 1A for each individual output. Typical dropout voltage at 1A load current is 1.3V. Each individual output voltage can be set independently as fixed voltage (e.g. 1.2V, 1.8V, 2.5V, 3.3V, 5V) or adjustable output which can provide an output voltage from 1.25 to 12V with two external resistors. The output accuracy of each channel is set within 2% by trimming.

LC1118 offers thermal shut down and current limit functions to ensure reliability of device and power system.

Package input/output pin configuration can be customized on demand (i.e. both output can share one input to save one input capacitor and corresponding PCB real estate).

LC1118 is available in lead (Pb)-free ESOP-8(with exposed pad for heat dissipation) package.

### FEATURES

- Dual channel output with each individual output can be either fixed output version or adjustable version.
- Maximum output current for each channel is 1A
- Range of operation input voltage: Max 12V
- Standby current of each output: 2mA (typ.)
- Line regulation: 0.1%/V (typ.)
- Load regulation: 10mV (typ.)
- Environment temperature: -20°C~85°C
- Compatible with tantalum capacitor, electrolytic capacitor and MLCC.

### APPLICATIONS

- Power management for computer mother board, graphic card
- LCD monitor and LCD TV
- DVD decoder board
- ADSL modem
- Post regulators for switching supplies

### TYPICAL APPLICATION

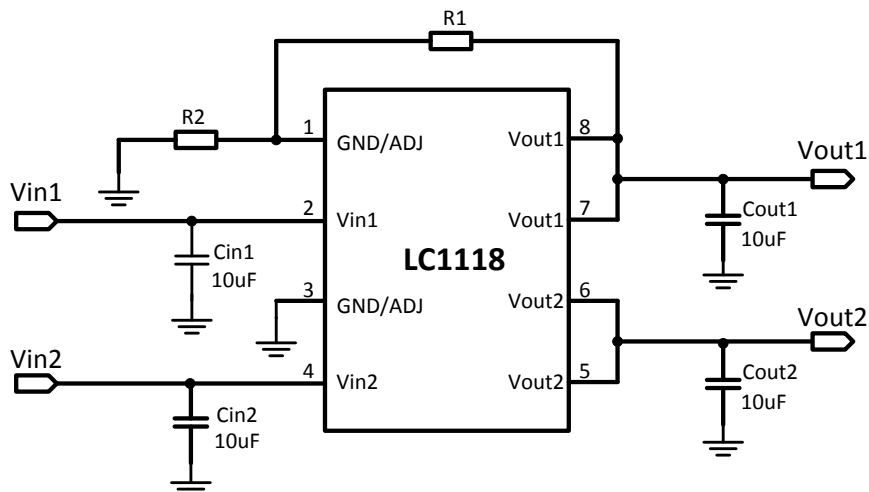

Fig.1. Typical application of LC1118

## ORDERING INFORMATION

LC1118 [1](#) [2](#) [3](#) [4](#) [5](#)

Code	Description
<a href="#">1</a>	Temperature&RoHS: C:-40~85°C , Pb Free RoHS Std.
<a href="#">2</a>	Package type: S8: ESOP-8
<a href="#">3</a>	Packing type: TR: Tape&Reel (Standard)
<a href="#">4</a>	CH1 Output voltage: e.g. 33=3.3V AD=ADJ
<a href="#">5</a>	CH2 Output voltage: e.g. 33=3.3V AD=ADJ

## MARKING DESCRIPTON

Marking	LC1118CS8TR□□□□
1118	Product Code
LLLL	Lot No.
XXYY	XX: Vo1 Output Voltage YY: Vo2 Output Voltage

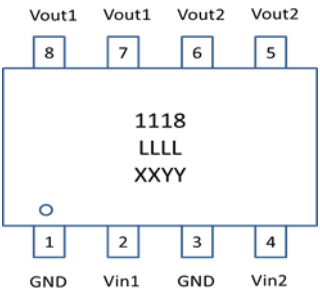

## PIN CONFIGURATION

PIN	Symbol	Description
1	GND	Ground
2	Vin1	Channel 1 Input
3	GND	Ground
4	Vin2	Channel 2 Input
5	Vout2	Channel 2 Output
6	Vout2	Channel 2 Output
7	Vout1	Channel 1 Output
8	Vout1	Channel 1 Output

## ABSOLUTE MAXIMUM RATING

Parameter	Value
Max input voltage	12V
Operating junction temperature(T <sub>j</sub> )	150°C
Ambient temperature(T <sub>A</sub> )	-20°C -85°C
Package thermal resistance(θ <sub>JC</sub> )	ESOP8 10°C / W
Storage temperature(T <sub>S</sub> )	-40°C -150°C
Lead temperature & time	260°C,10S

### Note:

- 1) Exceed these limits to damage to the device.
- 2) Exposure to absolute maximum rating conditions may affect device reliability.

## RECOMMENDED WORK CONDITIONS

Parameter	Value
Input voltage range	Max. 12V
Ambient temperature	-20°C ~ 85°C

## ELECTRICAL CHARACTERISTICS

\*For each individual channel output

Test Conditions:  $C_{in}=0.1\mu F$ ,  $C_{out}=10\mu F$ ,  $T_A=25\text{ }^\circ\text{C}$ , unless otherwise specified.

Symbol	Parameter	Conditions	Min	Typ	Max	Unit
$V_{REF}$	Reference voltage	LC1118-ADJ $10\text{mA}\leq I_{out}\leq 1\text{A}$ , $V_{in}=3.25\text{V}$	1.225	1.25	1.275	V
$V_{OUT}$	Output voltage	LC1118-1.2V $0\leq I_{out}\leq 1\text{A}$ , $V_{in}=3.2\text{V}$	1.176	1.2	1.224	V
		LC1118-1.8V $0\leq I_{out}\leq 1\text{A}$ , $V_{in}=3.8\text{V}$	1.764	1.8	1.836	V
		LC1118-2.5V $0\leq I_{out}\leq 1\text{A}$ , $V_{in}=4.5\text{V}$	2.45	2.5	2.55	V
		LC1118-3.3V $0\leq I_{out}\leq 1\text{A}$ , $V_{in}=5.3\text{V}$	3.234	3.3	3.366	V
		LC1118-5.0V $0\leq I_{out}\leq 1\text{A}$ , $V_{in}=7.0\text{V}$	4.9	5	5.1	V
$\Delta V_{OUT}$	Line regulation	LC1118-1.2V $I_{out}=10\text{mA}$ , $2.7\text{V}\leq V_{in}\leq 10\text{V}$		0.1	0.2	%/V
		LC1118-ADJ $I_{out}=10\text{mA}$ , $2.75\text{V}\leq V_{in}\leq 12\text{V}$		0.1	0.2	%/V
		LC1118-1.8V $I_{out}=10\text{mA}$ , $3.3\text{V}\leq V_{in}\leq 12\text{V}$		0.1	0.2	%/V
		LC1118-2.5V $I_{out}=10\text{mA}$ , $4.0\text{V}\leq V_{in}\leq 12\text{V}$		0.1	0.2	%/V
		LC1118-3.3V $I_{out}=10\text{mA}$ , $4.8\text{V}\leq V_{in}\leq 12\text{V}$		0.1	0.2	%/V
		LC1118-5.0V $I_{out}=10\text{mA}$ , $6.5\text{V}\leq V_{in}\leq 12\text{V}$		0.1	0.2	%/V
$\Delta V_{OUT}$	Load regulation	LC1118-ADJ $V_{in}=2.75\text{V}$ , $10\text{mA}\leq I_{out}\leq 1\text{A}$		10	30	mV
		LC1118-ADJ $V_{in}=2.75\text{V}$ , $10\text{mA}\leq I_{out}\leq 1\text{A}$		10	30	mV
		LC1118-1.8V $V_{in}=3.3\text{V}$ , $10\text{mA}\leq I_{out}\leq 1\text{A}$		10	30	mV
		LC1118-2.5V $V_{in}=4.0\text{V}$ , $10\text{mA}\leq I_{out}\leq 1\text{A}$		10	30	mV
		LC1118-3.3V $V_{in}=4.8\text{V}$ , $10\text{mA}\leq I_{out}\leq 1\text{A}$		10	30	mV
		LC1118-5.0V $V_{in}=6.5\text{V}$ , $10\text{mA}\leq I_{out}\leq 1\text{A}$		10	30	mV

## ELECTRICAL CHARACTERISTICS continued

Symbol	Parameter	Conditions	Min	Typ	Max	Unit
$V_{\text{DROP}}$	Dropout voltage	$I_{\text{out}}=100\text{mA}$		1.23	1.3	V
		$I_{\text{out}}=1\text{A}$		1.3	1.5	V
$I_{\text{LIMIT}}$	Current limit	$V_{\text{in}}-V_{\text{out}}=2\text{V}$ , $T_{\text{j}}=25^{\circ}\text{C}$	1			A
$I_{\text{MIN}}$	Minimum load current	LC1118-ADJ		2	10	mA
$I_{\text{Q}}$	Quiescent current	LC1118-1.2V, $V_{\text{in}}=10\text{V}$		2	5	mA
		LC1118-1.8V, $V_{\text{in}}=12\text{V}$		2	5	mA
		LC1118-2.5V, $V_{\text{in}}=12\text{V}$		2	5	mA
		LC1118-3.3V, $V_{\text{in}}=12\text{V}$		2	5	mA
		LC1118-5.0V, $V_{\text{in}}=12\text{V}$		2	5	mA
$I_{\text{ADJ}}$	Adjust pin current	LC1118-ADJ $V_{\text{in}}=5\text{V}$ , $10\text{mA}\leq I_{\text{out}}\leq 1\text{A}$		55	120	$\mu\text{A}$
$I_{\text{CHANGE}}$	$I_{\text{ADJ}}$ change	LC1118-ADJ $V_{\text{in}}=5\text{V}$ , $10\text{mA}\leq I_{\text{out}}\leq 1\text{A}$		0.2	10	$\mu\text{A}$
$\Delta V/\Delta T$	Temperature coefficient			$\pm 100$		ppm
$\theta_{\text{JA}}$	Junction-ambient thermal resistance	ESOP-8		63		$^{\circ}\text{C}/\text{W}$

**Note:**

- 1) All test are conducted under ambient temperature  $25^{\circ}\text{C}$  and within a short period of time 20ms
- 2) Load current smaller than minimum load current of LC1118-ADJ will lead to unstable or oscillation output.

## BLOCK DIAGRAM

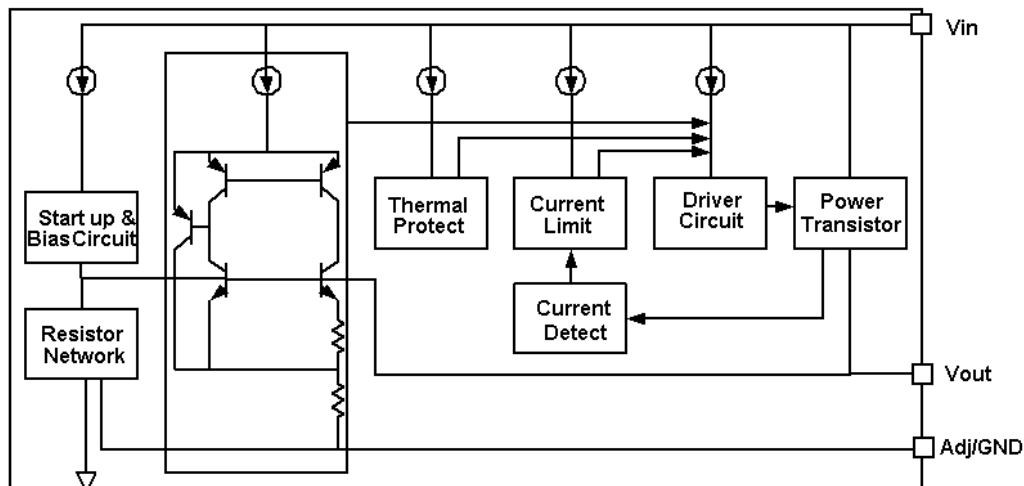

Fig.2 Block diagram for each individual channel

## DETAILED DESCRIPTION

LC1118 is a series of dual channel low-dropout regulator that delivers a maximum current of 1A for each individual output. Typical dropout voltage at 1A load current is 1.3V. Each individual output voltage can be set independently as fixed voltage (i.e. 1.2V, 1.8V, 2.5V, 3.3V, 5V) or adjustable output which can provide an output voltage ranges from 1.25 to 12V with two external resistors. The output accuracy of each channel is set within 2% by trimming.

The device has build-in modules including start-up circuit, bias circuit, bandgap, thermal shutdown, current limit, power transistors and driver circuit. Thermal shut down and current limit functions ensure reliability of device and power system.

The bandgap module provides stable reference voltage whose temperature coefficient is compensated by careful design considerations. The temperature coefficient is under 100 ppm/°C. The accuracy of output voltage is guaranteed by trimming technique.

Package input/output pin configuration can be customized on demand (i.e. both output can share one input to save one input capacitor and corresponding PCB real estate).

LC1118 is available in lead (Pb)-free ESOP-8 package.

## TYPICAL APPLICATION

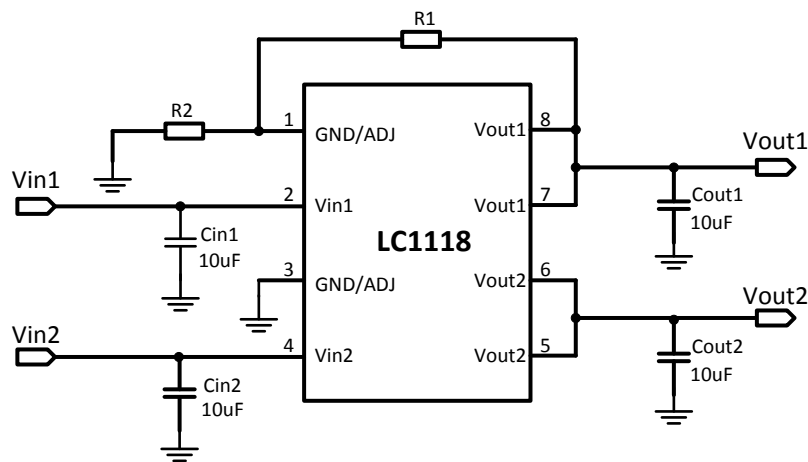

Fig.3. Typical application schematic of LC1118

LC1118 has both fixed voltage version (1.2V, 1.8V, 2.5V, 3.3V, 5V ) and adjustable voltage version. The input and output capacitors of each channel can be either tantalum, electrolytic or ceramic capacitor.

Figure 3 shows both fixed voltage and adjustable voltage application schematic. Channel 1 (designated as pin 1\2\7\8) is the schematic of adjustable version application. Channel 2 (designated as pin 3\4\5\6) is a typical application of fixed voltage. The adjustable version provides a 1.25V reference voltage with regard to its ADJ pin (shown as PIN 7\8 as its output and PIN1 as its adjustable pin in Fig.3). The output voltage of adjustable version follows the equation:

$$V_{out} = 1.25 \times (1 + R_2/R_1) + I_{ADJ} \times R_2.$$

We can ignore  $I_{ADJ}$  because  $I_{ADJ}$  (about 50uA) is much less than the current of R1 (in the order of several milliamps).

1) To meet the minimum load current (>10mA) requirement, R1 is recommended to be 125ohm or lower.

2) Using a bypass capacitor ( $C_{ADJ}$ ) between the ADJ pin and ground can improve ripple rejection. This bypass capacitor prevents ripple from being amplified as the output voltage is increased. The impedance of  $C_{ADJ}$  should be less than R1 to prevent ripple from being amplified. As R1 is normally in the range of 100Ω~500Ω, the value of  $C_{ADJ}$  should satisfy this equation:  $1/(2\pi \times f_{ripple} \times C_{ADJ}) < R1$ .

## THERMAL CONSIDERATIONS

Thermal consideration has to be taken account into to ensure proper function of the device. Power dissipation of LC1118 can be calculated as

$$\text{Power Dissipation} = (V_{in1} - V_{out1}) \times I_{out1} + (V_{in2} - V_{out2}) \times I_{out2}$$

For proper function and safe operation of the device, power dissipation is recommended to be limited within 2W.

## TYPICAL PERFORMANCE CHARACTERISTICS

$T=25^{\circ}\text{C}$  unless specified.

### Line Regulation

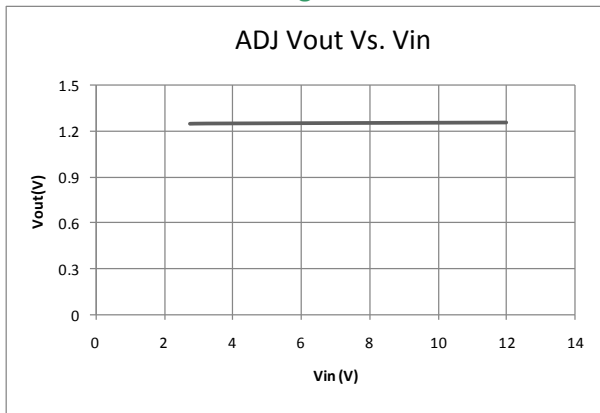

### Load Regulation

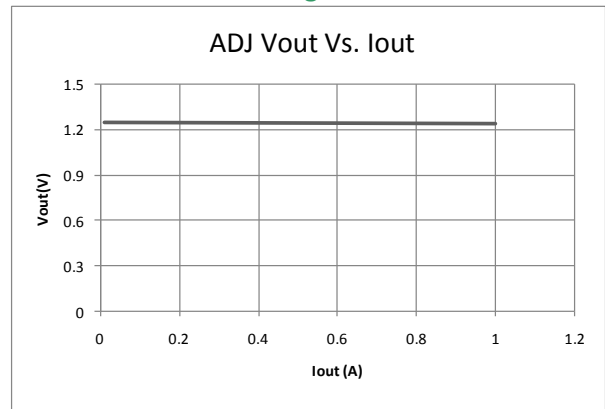

### Dropout Voltage

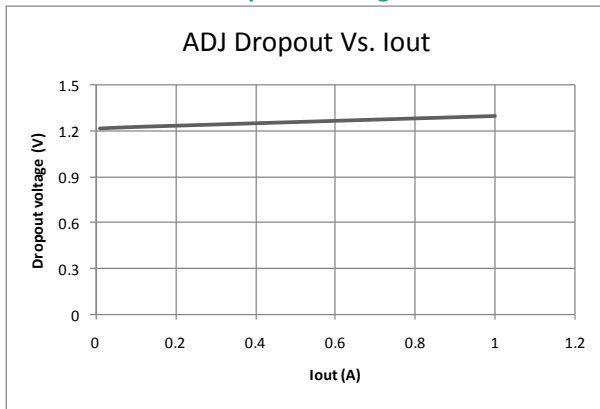

### Thermal performance with OTP

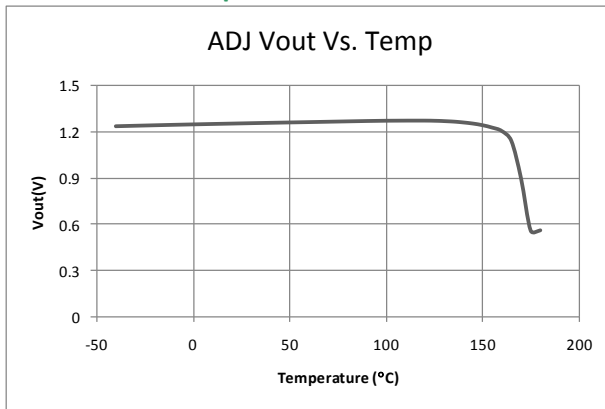

## PACKAGE OUTLINE

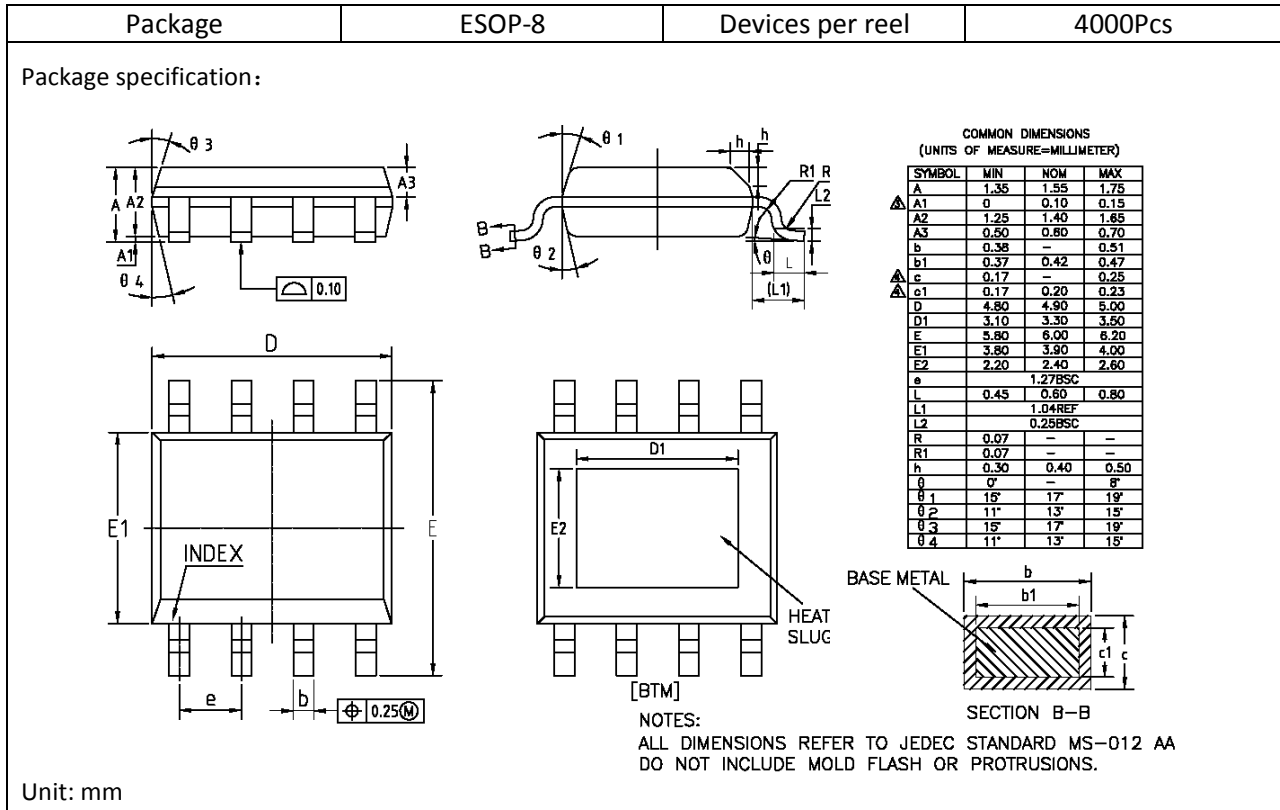



## X-ON Electronics

Largest Supplier of Electrical and Electronic Components

*Click to view similar products for [LDO Voltage Regulators](#) category:*

*Click to view products by [LEADCHIP](#) manufacturer:*

Other Similar products are found below :

[M38D29FFHP#U1](#) [702103A](#) [717726C](#) [742457H](#) [MP20051DN-LF-Z](#) [R5F111PGGFB#30](#) [AP7363-SP-13](#) [NCP103AMX285TCG](#)  
[NCV8664CST33T3G](#) [NCV8752AMX28TCG](#) [L9454](#) [AP7362-HA-7](#) [LX13043CLD](#) [TCR3DF185,LM\(CT](#) [TCR3DF24,LM\(CT](#)  
[TCR3DF285,LM\(CT](#) [TCR3DF31,LM\(CT](#) [TCR3DF45,LM\(CT](#) [TLF4949EJ](#) [L9708](#) [L970813TR](#) [030014BB](#) [059985X](#) [EAN61387601](#)  
[EAN61573601](#) [NCP121AMX173TCG](#) [NCP4687DH15T1G](#) [NCV8703MX30TCG](#) [701326R](#) [702087BB](#) [755078E](#) [TCR2EN28,LF\(S](#)  
[LM1117DT-1.8/NO](#) [LT1086CM#TRPBF](#) [AZ1085S2-1.5TRE1](#) [MAX15101EWL+T](#) [NCV8170AXV250T2G](#) [SCD337BTG](#)  
[TCR3DF27,LM\(CT](#) [TCR3DF19,LM\(CT](#) [TCR3DF125,LM\(CT](#) [TCR2EN18,LF\(S](#) [MAX15103EWL+T](#) [TS2937CZ-5.0 C0](#) [MAX8878EUK30-](#)  
[T](#) [MAX663CPA](#) [NCV4269CPD50R2G](#) [NCV8716MT30TBG](#) [AZ1117IH-1.2TRG1](#) [MP2013GQ-P](#)