

LEGM75TD120E2H

IGBT Power Module

Features:

- $V_{CE}=1200V$ $I_C=75A$
- Low $V_{CE(sat)}$
- V_{CEsat} with positive temperature coefficient
- Maximum junction temperature $150^{\circ}C$
- Isolation Type Package

Applications:

- The inverter
- Motor control and drives

Package Type & Internal Circuit

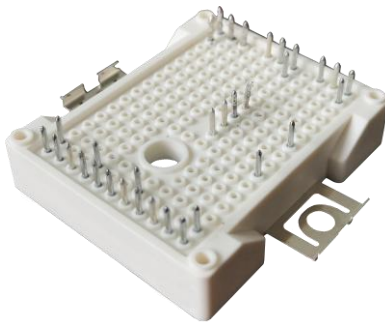

E2

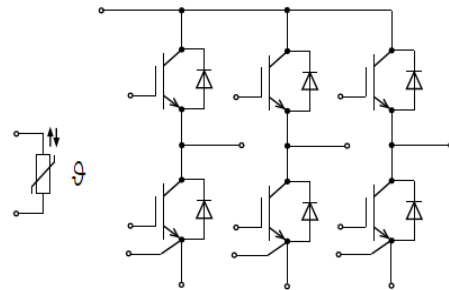

Internal Circuit

Maximum Rated Values (IGBT Inverter)

Symbol	Parameter	Conditions	Ratings	Unit
V_{CES}	Collector-emitter voltage	$V_{EC}= 0 V, I_C= 1 mA, T_{vj}= 25^{\circ}C$	1200	V
I_C	Continuous Collector Current	$T_C=100^{\circ}C$	75	A
I_{CRM}	Peak Collector Current	$I_{CRM}= 2 I_C$	150	A
V_{GES}	Gate-Emitter Voltage	$T_{vj}= 25^{\circ}C$	± 30	V
P_{tot}	Total Power Dissipation	$T_C= 25^{\circ}C, T_{vjmax}= 150^{\circ}C$	350	W

Characteristics Values (IGBT Inverter)

Symbol	Parameter	Conditions	Min.	Typ.	Max.	Unit	
$V_{CE(sat)}$	Collector-Emitter Saturation Voltage	$I_C = 75\text{ A}, V_{GE} = 15\text{ V}, T_{vj} = 25\text{ }^\circ\text{C}$		1.78		V	
		$I_C = 75\text{ A}, V_{GE} = 15\text{ V}, T_{vj} = 125\text{ }^\circ\text{C}$		1.97		V	
$V_{GE(th)}$	Gate Threshold Voltage	$I_C = 5.0\text{ mA}, V_{CE} = V_{GE}, T_{vj} = 25\text{ }^\circ\text{C}$		5.8		V	
I_{CES}	Collector-Emitter Cut-off Current	$V_{CE} = 1200\text{ V}, V_{GE} = 0\text{ V}, T_{vj} = 25\text{ }^\circ\text{C}$			1.2	mA	
I_{GES}	Gate-Emitter Leakage Current	$V_{CE} = 0\text{ V}, V_{GE} = 15\text{ V}, T_{vj} = 25\text{ }^\circ\text{C}$			410	nA	
$t_{d(on)}$	Turn-on Delay Time, Inductive Load	$I_C = 75\text{ A}, V_{CE} = 600\text{ V}$ $V_{GE} = \pm 15\text{ V}$ $R_G = 2\ \Omega$ $T_{vj} = 25\text{ }^\circ\text{C}$		110		ns	
t_r	Rise Time, Inductive Load			35		ns	
$t_{d(off)}$	Turn-off Delay Time, Inductive Load			270		ns	
t_f	Fall Time, Inductive Load			170		ns	
E_{on}	Turn-on Energy Loss per Pulse			1.9		mJ	
E_{off}	Energy Loss per Pulse			4.8		mJ	
$t_{d(on)}$	Turn-on Delay Time, Inductive Load		$I_C = 75\text{ A}, V_{CE} = 600\text{ V}$ $V_{GE} = \pm 15\text{ V}$ $R_G = 2\ \Omega$ $T_{vj} = 125\text{ }^\circ\text{C}$		110		ns
t_r	Rise Time, Inductive Load				40		ns
$t_{d(off)}$	Turn-off Delay Time, Inductive Load				320		ns
t_f	Fall Time, Inductive Load				280		ns
E_{on}	Turn-on Energy Loss per Pulse			2.4		mJ	
E_{off}	Energy Loss per Pulse			7.5		mJ	
R_{thJC}	Thermal resistance, junction to case	per IGBT				0.35	K/W
$T_{vj\ op}$	Temperature under switching conditions		-40		125	$^\circ\text{C}$	
I_{SC}	SC data	$V_{GE} \leq 15\text{ V}, V_{CC} = 600\text{ V}$ $V_{CEmax} = V_{CES} - L_{sCE} \cdot di/dt$ $t_p \leq 10\ \mu\text{s}, T_{vj} = 125\text{ }^\circ\text{C}$		400		A	

Maximum Rated Values (Diode Inverter)

Symbol	Parameter	Conditions	Min.	Typ.	Max.	Unit
V_{RRM}	Repetitive Peak Reverse Voltage	$T_{vj}= 25\text{ }^{\circ}\text{C}$		1200		V
I_F	Continuous DC Forward Current	$T_C= 100\text{ }^{\circ}\text{C}$		75		A
I_{FRM}	Repetitive Peak Forward Current	$t_p= 1\text{ ms}$		150		A
I^2t	I^2t Value	$V_R= 0\text{ V}$, $t_p= 10\text{ ms}$, $T_{vj}= 125\text{ }^{\circ}\text{C}$		1200		A ² s

Characteristic Values (Diode Inverter)

Symbol	Parameter	Conditions	Min.	Typ.	Max.	Unit
V_F	Forward Voltage	$I_F= 75\text{ A}$, $V_{CE}= 0\text{ V}$, $T_{vj}= 25\text{ }^{\circ}\text{C}$		1.79		V
		$I_F= 75\text{ A}$, $V_{CE}= 0\text{ V}$, $T_{vj}= 125\text{ }^{\circ}\text{C}$		1.96		V
t_{rr}	Reverse Recovery time	$I_F= 75\text{ A}$, $V_R= 600\text{ V}$ -di/dt = 2000 A/us $T_{vj}= 25\text{ }^{\circ}\text{C}$		100		ns
Q_r	Recovered Charge			15.6		uC
E_{rec}	Reverse Recovery Energy			0.5		mJ
t_{rr}	Reverse Recovery time	$I_F= 75\text{ A}$, $V_R= 600\text{ V}$ -di/dt = 2000 A/us $T_{vj}= 125\text{ }^{\circ}\text{C}$		120		ns
Q_r	Recovered Charge			23.4		uC
E_{rec}	Reverse Recovery Energy			1.3		mJ
R_{thJC}	Thermal resistance, junction to case	per Diode			0.65	K/W
$T_{vj\text{op}}$	Temperature under switching conditions		-40		125	$^{\circ}\text{C}$

NTC-Thermistor (Characteristic Values)

Symbol	Parameter	Conditions	Min.	Typ.	Max.	Unit
R ₂₅	Rated resistance	T _c = 25 °C		5		KΩ
ΔR/R	Deviation of R100	T _c = 100 °C	-5		5	%
P ₂₅	Power dissipation	T _c = 25 °C		20		mW
B _{25/50}	B-value	$R_2 = R_{25} \exp[B_{25/50}(1/T_2 - 1/(298,15K))]$		3380		K
B _{25/100}	B-value	$R_2 = R_{25} \exp[B_{25/100}(1/T_2 - 1/(298,15K))]$		3450		K

Module Characteristics

Symbol	Parameter	Conditions	Min.	Typ.	Max.	Unit
V _{isol}	Isolation voltage	t= 1 min, f= 50 Hz	2500			V
T _{stg}	Storage Temperature		-40		150	°C
F	Mounting Force per Clamp		40		80	N
G	Weight of Module			40		g

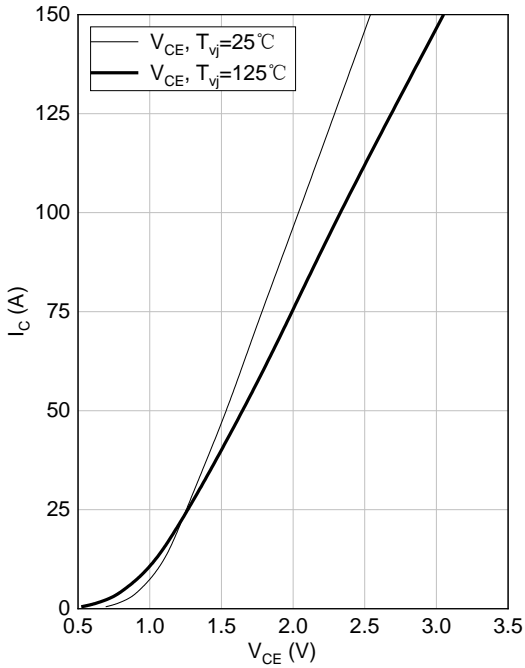
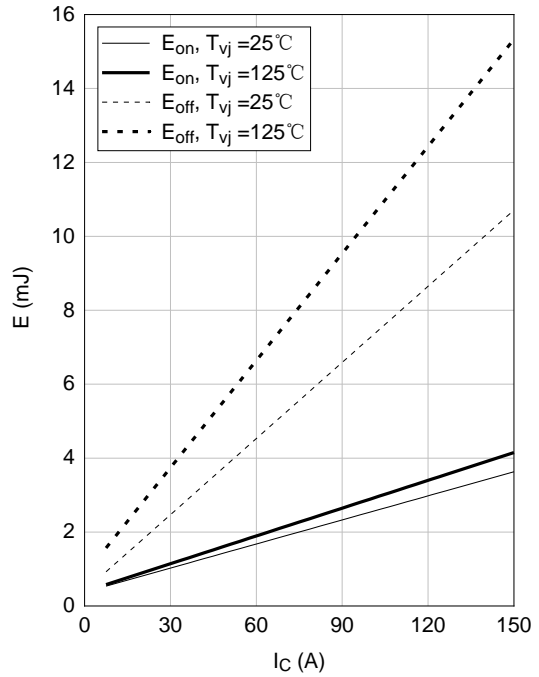
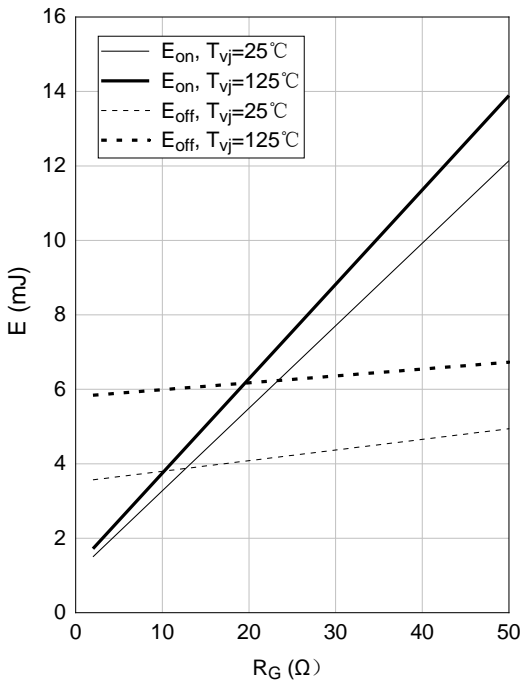
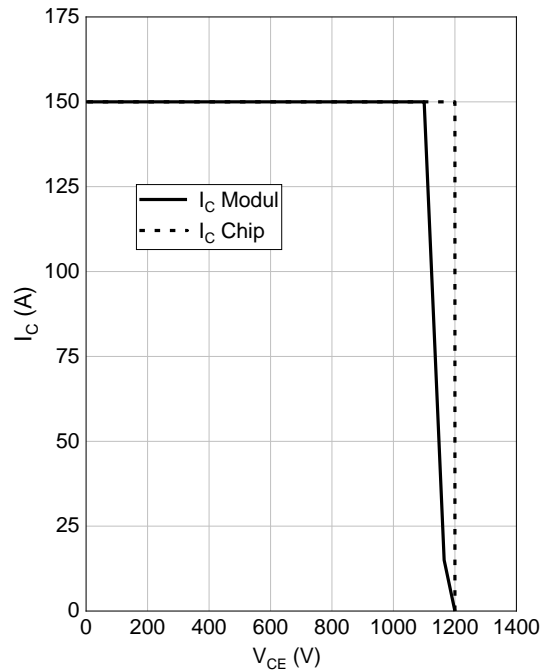
Output characteristic of IGBT, Inverter (typical)
 $I_C = f(V_{CE})$
 $V_{GE} = 15\text{ V}$

Switching losses IGBT, Inverter (typical)
 $E_{on} = f(I_C), E_{off} = f(I_C)$
 $V_{GE} = \pm 15\text{ V}, R_G = 2\ \Omega, V_{CE} = 600\text{ V}$

Switching losses IGBT, Inverter (typical)
 $E_{on} = f(R_G), E_{off} = f(R_G)$
 $V_{GE} = \pm 15\text{ V}, I_C = 75\text{ A}, V_{CE} = 600\text{ V}$

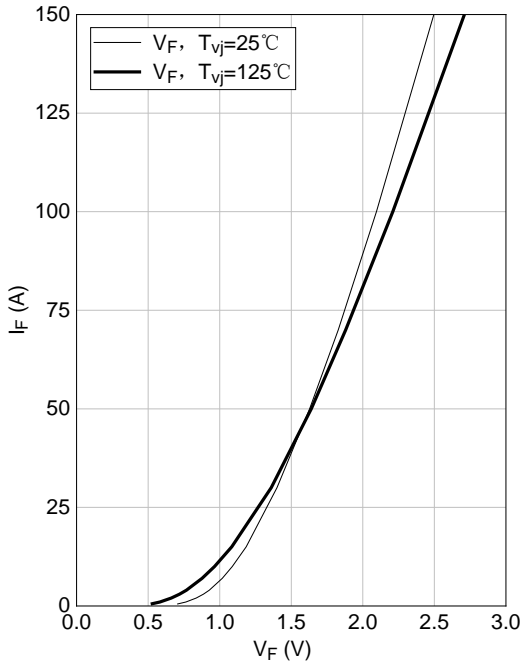
RBSOA IGBT, Inverter (typical)
 $I_C = f(V_{CE})$
 $V_{GE} = \pm 15\text{ V}, R_G = 50\ \Omega, T_{vj} = 125^\circ\text{C}$

Forward characteristic of Diode, Inverter (typical)

$$I_F = f(V_F)$$



Switching losses Diode, Inverter (typical)

$$E_{rec} = f(R_G)$$

$$I_F = 75 \text{ A}, V_{CE} = 600 \text{ V}$$

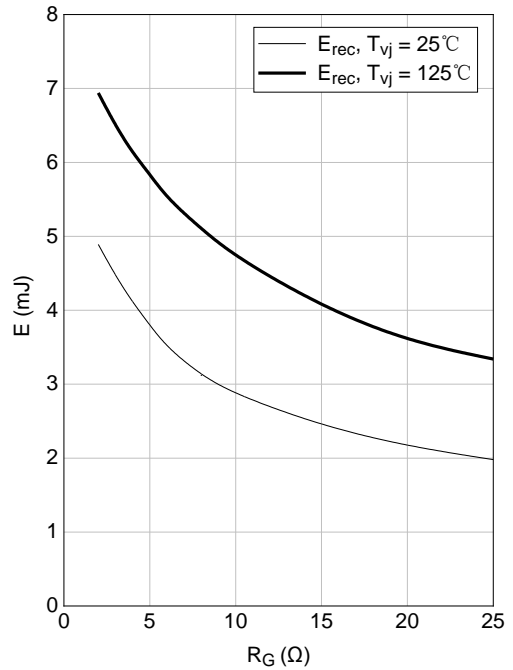

Switching losses Diode, Inverter (typical)

$$E_{rec} = f(I_F)$$

$$R_G = 2 \Omega, V_{CE} = 600 \text{ V}$$

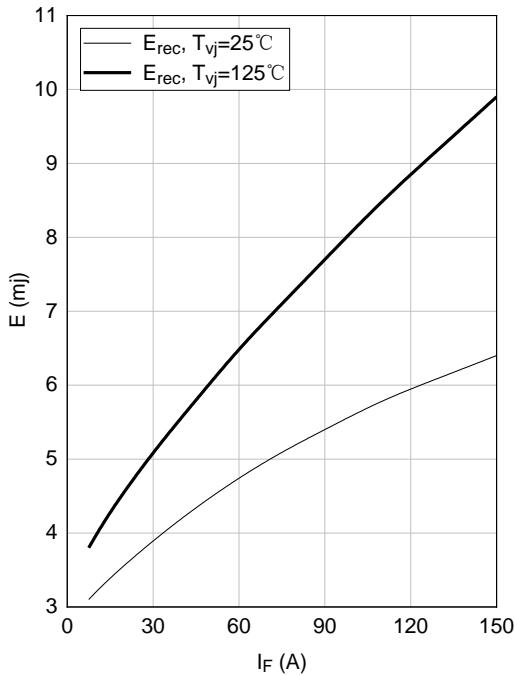

NTC-Thermistor-temperature characteristic (typical)

$$R = f(T)$$

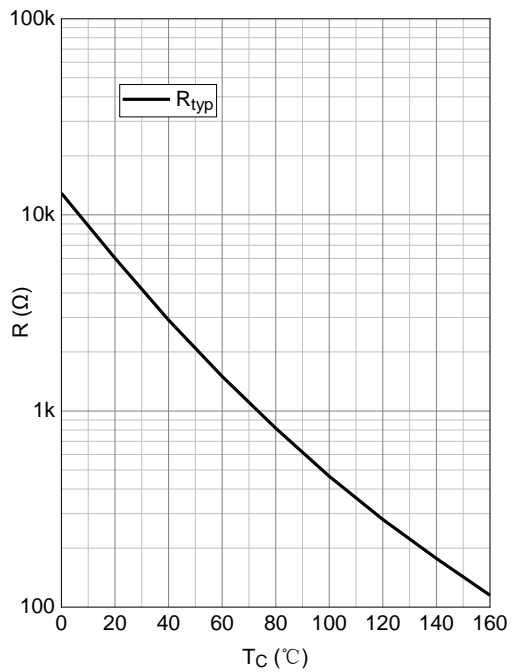

Circuit Diagram

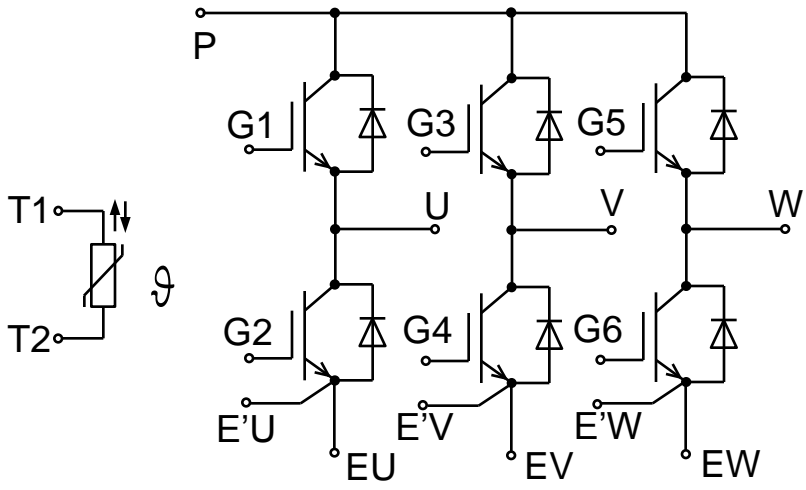

Package Dimensions

(Dimensions in Millimeters)

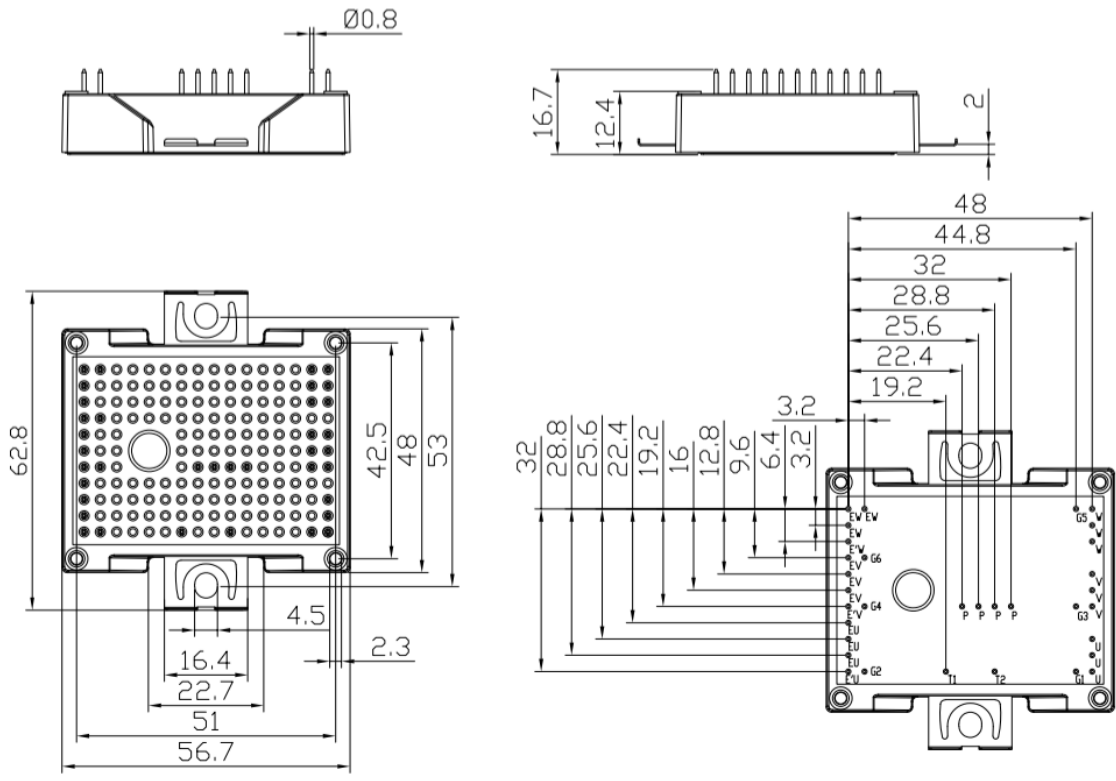

DISCLAIMER

ALL PRODUCT, PRODUCT SPECIFICATIONS AND DATA ARE SUBJECT TO CHANGE WITHOUT NOTICE TO IMPROVE RELIABILITY, FUNCTION OR DESIGN OR OTHERWISE

X-ON Electronics

Largest Supplier of Electrical and Electronic Components

Click to view similar products for [IGBT Transistors](#) category:

Click to view products by [Leading Energy](#) manufacturer:

Other Similar products are found below :

[IRG4PC30W](#) [APT20GT60BRDQ1G](#) [STGWA25H120DF2](#) [APT30GS60BRDQ2G](#) [TIG058E8-TL-H](#) [IDW40E65D2](#) [STGB40V60F](#)
[STGWA25H120F2](#) [NGTB75N65FL2WAG](#) [2MBI150VA-060-50](#) [NTE3320](#) [FGD3040G2-F085](#) [FGD3440G2-F085](#) [STGW80H65DFB-4](#)
[AFGY160T65SPD-B4](#) [IGW30N60TP](#) [IGW40N60TP](#) [IGW50N60TP](#) [IHW30N65R5](#) [IKFW40N60DH3E](#) [IKP15N65H5](#) [IKQ100N60T](#)
[IKQ120N60T](#) [IKW30N65WR5](#) [IKW75N60H3](#) [IKZ50N65NH5](#) [IKZ75N65NH5](#) [FGD3040G2-F085C](#) [FGH4L50T65SQD](#) [FGHL40T65MQDT](#)
[FGHL50T65MQD](#) [FGHL50T65MQDTL4](#) [FGHL75T65LQDT](#) [FGHL75T65MQD](#) [FGHL75T65MQDT](#) [FGHL75T65MQDTL4](#)
[FGY75T120SWD](#) [EL3120S1\(TA\)\(SAS\)-V](#) [IHW15N120E1](#) [IKQ75N120CS6](#) [IKW50N65WR5](#) [SL15T65FK](#) [KGF50N65KDF-U/H](#)
[IHF40N65R5S](#) [IKW08N120CS7XKSA1](#) [IKQ75N120CH3](#) [IHW30N160R5](#) [SGM100HF12A1TFD](#) [CRG50T60AK3SD](#) [CRG40T60AN3S](#)