

Constant Voltage and Constant Current Controller

Rev. 00

General Description

The LD8105 is built-in with a high-accuracy 1.2V voltage reference, two op-amps and a low-side current sensing circuit in a SOT-26 package. It provides a highly integrated solution for CV (constant voltage) and CC (constant current) dual control. The LD8105 is capable to operate under temperature ranging from -40°C to 105°C.

Features

- Internal Precision $\pm 1\%$ Voltage Reference
- Secondary-side Constant Voltage and Constant Current Control
- Low Quiescent consumption
- Wide VCC operating range 3V to 38V
- Max. 40V voltage rating
- Low external component count
- SOT-26 Package

Applications

- LED Lighting

Typical Application

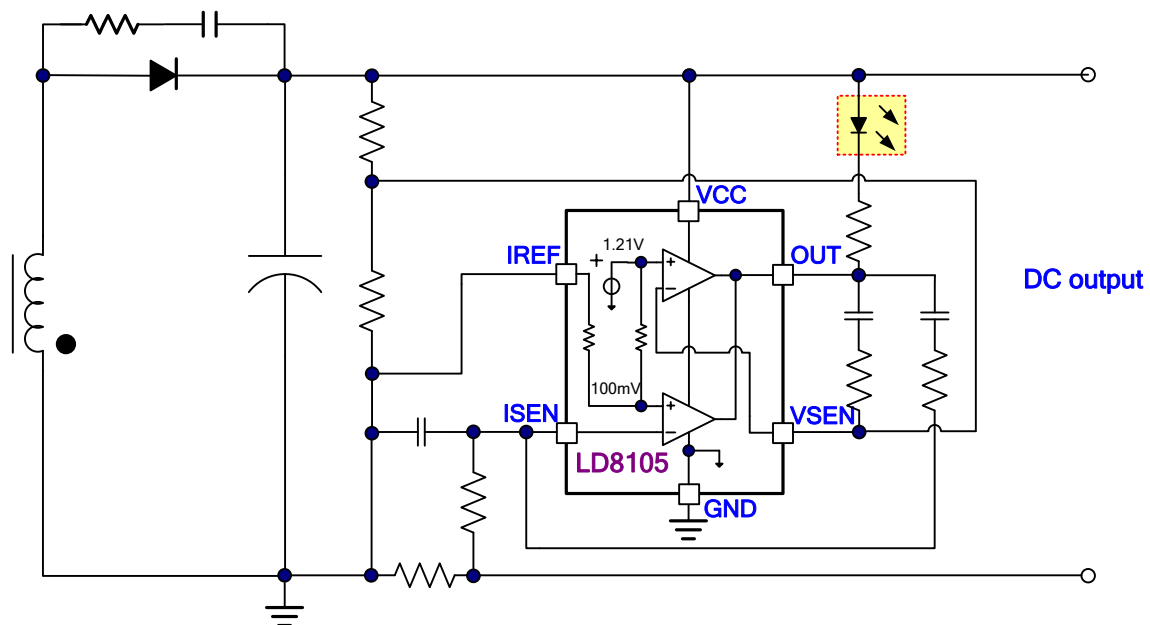

Fig. 1 Typical Application Circuit -1

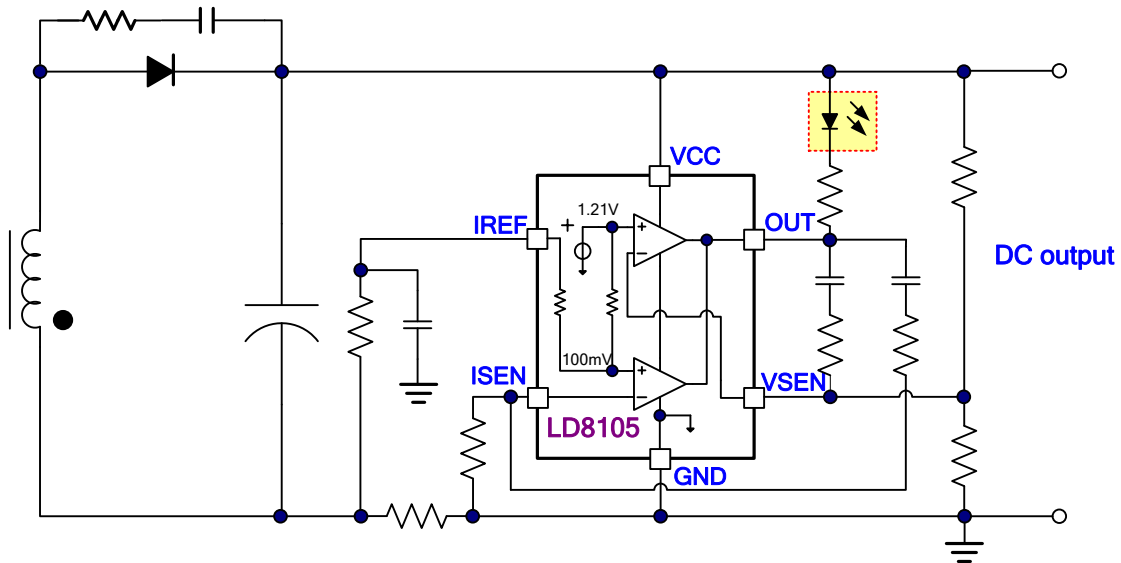
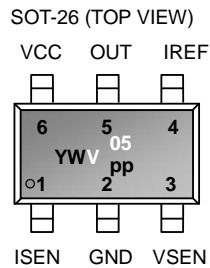

Fig. 2 Typical Application Circuit -2

Pin Configuration



Y : Year code (D: 2004, E: 2005.....)
W : Week code
PP : Production code
V05 : LD8105

Ordering Information

Part number	Package	TOP MARK	Shipping
LD8105GL	SOT-26	YWV/05	3000 /tape & reel

The LD8105 is Green Packaged.

Pin Descriptions

PIN	NAME	FUNCTION
1	ISEN	Current sense pin. The inverting input of the current loop op amp.
2	GND	Ground.
3	VSEN	Voltage sense pin. It can sense the output voltage if connected to the mid-point of the resistor divider.
4	IREF	The non-inverting input of the current loop op amp.
5	OUT	Common output pin of the two internal op amps.
6	VCC	Supply voltage pin. It is necessary to locate a 0.1 μ F bypass capacitor between VCC and GND.

Block Diagram

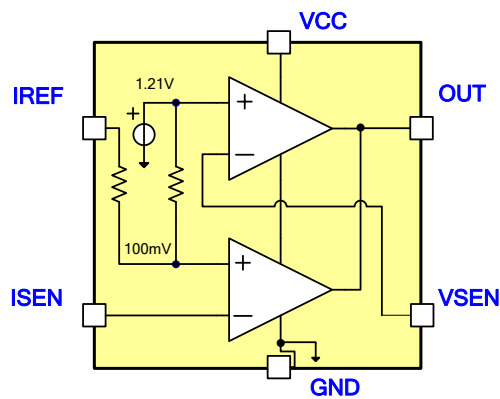

Absolute Maximum Ratings

Supply Voltage, Vcc	-0.3 ~40V
VSEN	-0.3~6V
ISEN	-0.3~6V
IREF	-0.6~6V
OUT	-0.3~Vcc
Maximum sink current	20mA
Maximum Junction Temperature	125°C
Operating Junction Temperature	-40°C to 125°C
Operating Ambient Temperature	-40°C to 85°C
Storage Temperature Range	-65°C to 150°C
Package Thermal Resistance	250°C/W
Power Dissipation (At Ambient Temperature = 85°C)	160mW
Lead temperature (Soldering, 10sec)	260°C
ESD Voltage Protection, Human Body Model	2 KV
ESD Voltage Protection, Machine Model	200 V

Caution:

Stresses beyond the ratings specified in “Absolute Maximum Ratings” may cause permanent damage to the device. This is a stress only rating and operation of the device at these or any other conditions above those indicated in the operational sections of this specification is not implied.

Recommended Operating Conditions

Item	Min.	Max.	Unit
Supply Voltage Vcc	3	38	V

Electrical Characteristics

($T_A = +25^\circ\text{C}$ unless otherwise stated, $V_{CC}=15.0\text{V}$)

PARAMETER	CONDITIONS	MIN	TYP	MAX	UNITS
Supply Voltage (Vcc Pin)					
Supply Voltage		3	--	38	V
Quiescent Current	$I_{SEN} = I_{REF} = 0\text{V}$, OUT = open	--	--	150	μA
Voltage Control Loop (VSEN PIN)					
Voltage loop reference voltage, VSEN	$I_{SEN} = I_{REF} = 0\text{V}$	1.198	1.210	1.222	V
	$I_{SEN} = I_{REF} = 0\text{V}$, ($T_A = -20^\circ\text{C} \sim 125^\circ\text{C}$)	1.186	--	1.234	V
Voltage Loop Input Bias Current	$V_{SEN} = 1.18\text{V} \sim 1.24\text{V}$	--	--	20	nA
Current Control Loop (IREF Pin)					
Current loop reference voltage, IREF	$V_{SEN} = 1.21\text{V}$	97	100	103	mV
Current Loop Input Bias Current	$I_{REF} = 90\text{mV} \sim 110\text{mV}$	--	--	20	nA
Output (Output Pin)					
Output Low Level	@2mA sink current	--	200	400	mV

Typical Performance Characteristics

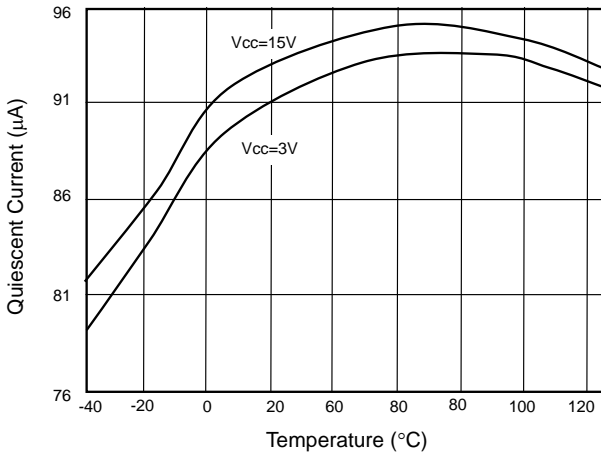

Fig. 1 Quiescent Current vs. Temperature

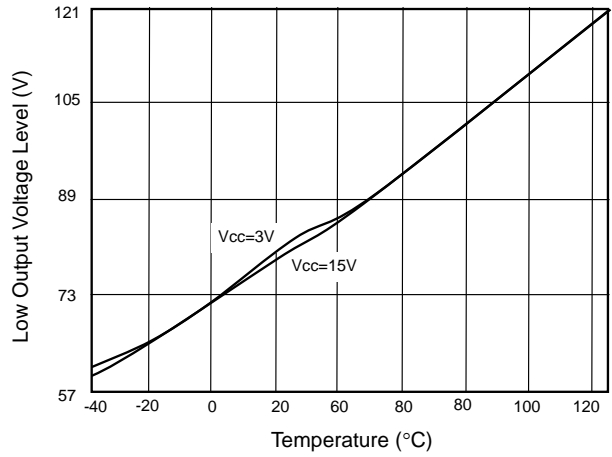

Fig. 2 Low Output Voltage Level vs. Temperature

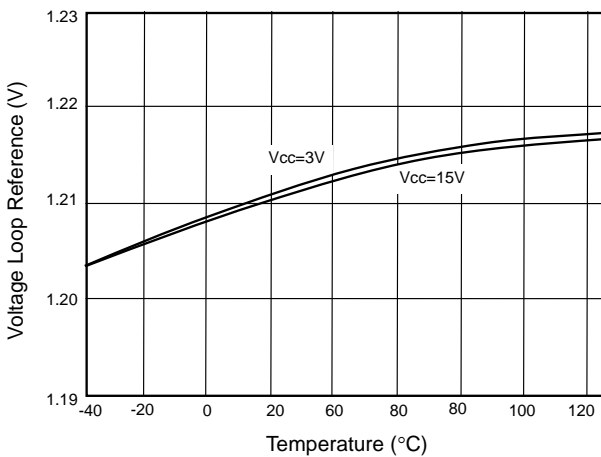

Fig. 3 Voltage Loop Reference vs. Temperature

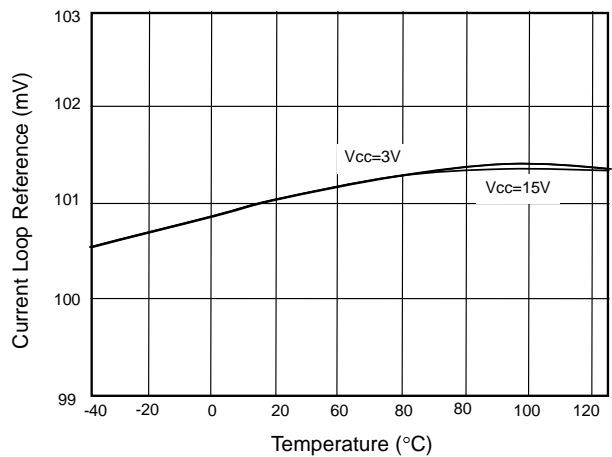
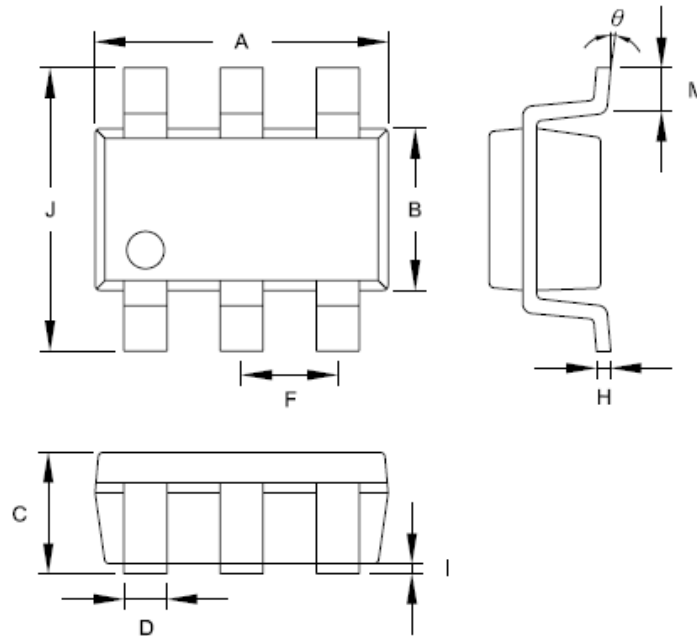

Fig. 4 Current Loop Reference vs. Temperature

Package Information

SOT-26



Symbol	Dimension in Millimeters		Dimensions in Inches	
	Min	Max	Min	Max
A	2.692	3.099	0.106	0.122
B	1.397	1.803	0.055	0.071
C	-----	1.450	-----	0.057
D	0.300	0.500	0.012	0.020
F	0.95 BSC.			
H	0.080	0.254	0.003	0.010
I	0.050	0.150	0.002	0.006
J	2.600	3.000	0.102	0.118
M	0.300	0.600	0.012	0.024
θ	0°	10°	0°	10°

Important Notice

Leadtrend Technology Corp. reserves the right to make changes or corrections to its products at any time without notice. Customers should verify the datasheets are current and complete before placing order.

Revision History

Rev.	Date	Change Notice
00	5/29/2012	Original Specification

X-ON Electronics

Largest Supplier of Electrical and Electronic Components

Click to view similar products for [Switching Voltage Regulators](#) category:

Click to view products by [Leadtrend](#) manufacturer:

Other Similar products are found below :

[FAN53610AUC33X](#) [FAN53611AUC123X](#) [MP2374DS-LF-Z](#) [EN6310QA](#) [NCP81108MNTXG](#) [NCP81109BMNTXG](#) [FAN48610BUC45X](#)
[FAN48617UC50X](#) [R3](#) [KE177614](#) [EP5358LUA](#) [MPQ4423GQ-AEC1-Z](#) [FAN53611AUC12X](#) [MAX809TTR](#) [NCV891234MW50R2G](#)
[AST1S31PUR](#) [NCP81103MNTXG](#) [NCP81203PMNTXG](#) [NCP81208MNTXG](#) [NCP81109GMNTXG](#) [SCY1751FCCT1G](#)
[NCP81109JMNTXG](#) [MP2161AGJ-Z](#) [NCP81241MNTXG](#) [MP2388GQEU-Z](#) [MPQ4481GU-AEC1-P](#) [MP8756GD-P](#) [MPQ2171GJ-P](#)
[IR3888MTRPBFAUMA1](#) [MPQ2171GJ-AEC1-P](#) [MP2171GJ-P](#) [NCV1077CSTBT3G](#) [MP28160GC-Z](#) [MPM3509GQVE-AEC1-P](#)
[LTM4691EV#PBF](#) [XCL207A123CR-G](#) [XDPE132G5CG000XUMA1](#) [XDPE12284C0000XUMA1](#) [LTM4691IV#PBF](#) [MP5461GC-P](#)
[MP28301GG-P](#) [MIC23356YFT-TR](#) [ISL95338IRTZ](#) [MP3416GJ-P](#) [BD9S201NUX-CE2](#) [ISL9113AIRAZ-T](#) [MP5461GC-Z](#) [MPQ2172GJ-](#)
[AEC1-Z](#) [MPQ4415AGQB-Z](#) [MPQ4590GS-Z](#)