

General description

The LM61089B series offers programmable SIDACTor overvoltage protection devices for SLIC applications. The Single Port Negative Battrax Series provides a programmable device that is referenced to a negative voltage source while internal diodes provide protection from positive surge events.

Features

- Dual Voltage-Tracking Protectors
- Wide negative pressure range: $V_{MGL} = -167V_{MAX}$
- Low dynamic switching voltage: V_{FP} and V_{DGL}
- Low gate triggering current : $I_{GT} = 5mA_{MAX}$
- Peak Pulse Current: $I_{PP} = 50A$ (10/700 μs)
- High Holding current : $I_H \geq 150mA$

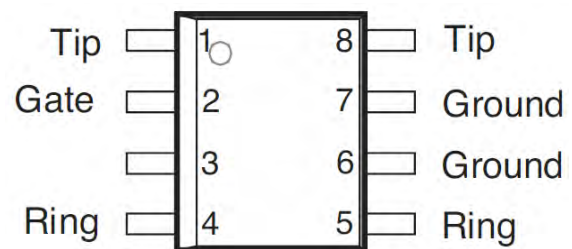

Circuit

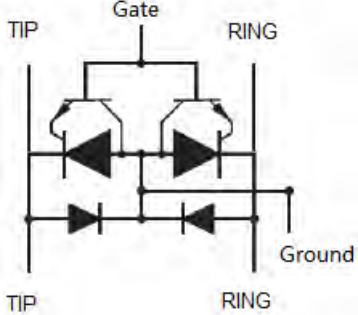
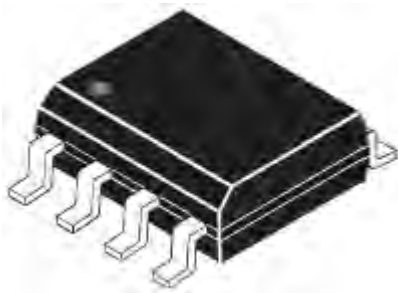
 <p>Pic.1 Device equivalent structure</p>	 <p>Pic.2 Device type SOP-8</p>
--	---

Electrical Parameters

► Standard

Type	Wave shape		I_{TSP}
ITU-T K.20/21	voltage	10/700 μ s	50A
ITU-T K.44/45	current	5/310 μ s	

► V-I characteristic curve ($T_a = 25^\circ\text{C}$)

symbol	parameters
I_H	Holding current
I_{RM}	Line-ground reverse leakage current
I_{RG}	Gate-line reverse leakage current
V_{RM}	Line-ground reverse voltage
V_F	Line-ground voltage
V_{GT}	gate trigger voltage
V_{FP}	Line-ground peak voltage
V_{DGL}	Gate-line dynamic switching voltage

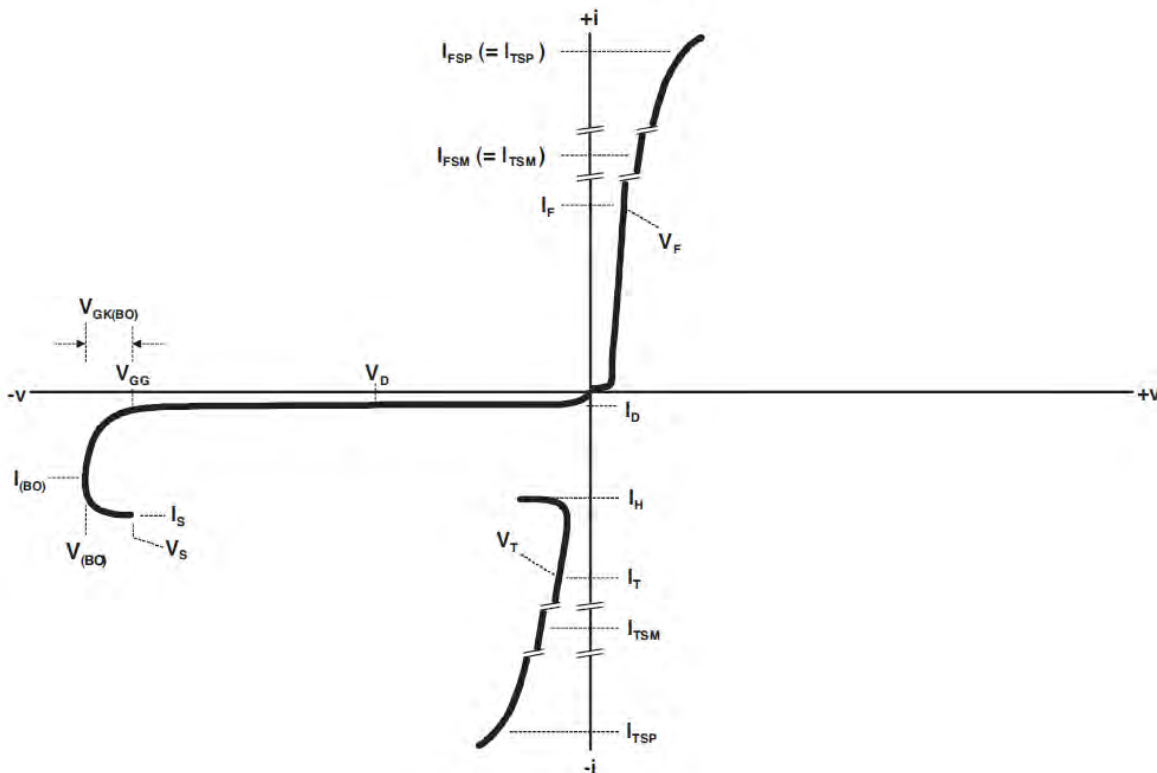

Electrical characteristics

- Absolute maximum ratings $T_a = 25^\circ\text{C}$ unless otherwise noted

symbol	parameters	value	unit	
V_{PP}/I_{PP}	Peak pulse voltage /current (tip.1)	10/700 μs	2000	V
		5/310 μs	50	A
I_{TSM}	Non repetitive peak pulse current (F=60Hz)	$t_p=500\text{ms}$	6.5	A
		$t=1\text{s}$	4.6	
I_{GSM}	Maximum gate current (half sinusoid $t_p=10\text{ms}$)	2	A	
V_{MLG}	Line-ground maximum voltage	-170	V	
V_{MGL}	Gate-line maximum voltage	-167	V	
T_{stg}	Storage Temperature Range	-55~150	$^\circ\text{C}$	
T_j	maximum temperature	150	$^\circ\text{C}$	
T_L	maximum sustainable temperature of solder in 10 seconds	260	$^\circ\text{C}$	

►Line-ground diode parameters

symbol	Test conditions	Max.	unit
V_F	$I_F=5\text{A}$, $t_p=500\mu\text{s}$	3	V
V_{FP}	10/700 μs 1.5kV $R_p=10\Omega$ (tip. 1)	5	V

► Thyristor parameters ($T_a=25^\circ\text{C}$)

symbol	Test conditions	Min.	Max.	unit
I_H	$V_{GATE}=-100\text{V}$	150		mA
V_{GT}	$V_{GND}/L_{INE}=-100\text{V}$		2.5	V
I_{RG}	$T_C=25^\circ\text{C}$ $V_{RG}=-170\text{V}$		5	μA
	$T_C=70^\circ\text{C}$ $V_{RG}=-170\text{V}$		50	
V_{DGL}	$V_{GATE}=-100\text{V}$ (TIP.3) 10/700 μs 1.5kV $R_p=10\Omega$		10	V

► Thyristor and diode parameters

Symbol	Test conditions	Max.	unit
I_{RM}	$T_C=25^{\circ}C$ $V_{GATE/LINE}=-1V$ $V_{RM}=-167$	5	μA
	$T_C=70^{\circ}C$ $V_{GATE/LINE}=-1V$ $V_{RM}=-167$	50	μA
C	$V_R=-3V$ $F=150KHZ$	100	pF
	$V_R=-48V$ $F=150KHZ$	50	pF

Package size

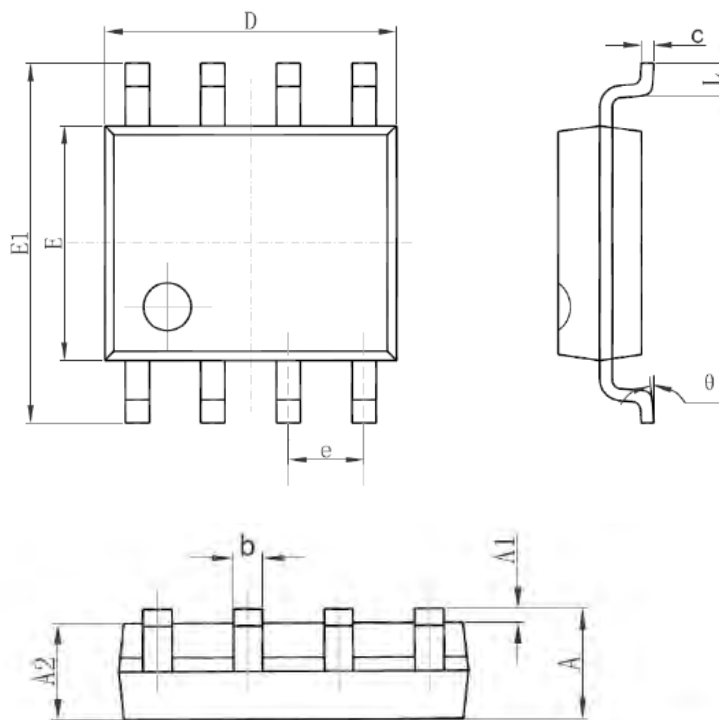

Symbol	Dimensions In Millimeters		Dimensions In Inches	
	Min	Max	Min	Max
A	1.350	1.750	0.053	0.069
A1	0.100	0.250	0.004	0.010
A2	1.350	1.550	0.053	0.061
b	0.330	0.510	0.013	0.020
c	0.170	0.250	0.006	0.010
D	4.700	5.100	0.185	0.200
E	3.800	4.000	0.150	0.157
E1	5.800	6.200	0.228	0.244
e	1.270(BSC)		0.050(BSC)	
L	0.400	1.270	0.016	0.050
theta	0°	8°	0°	8°

Package size

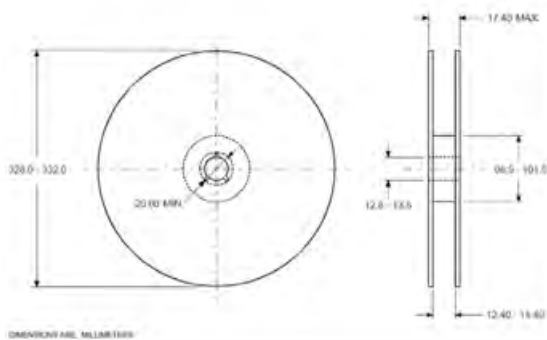
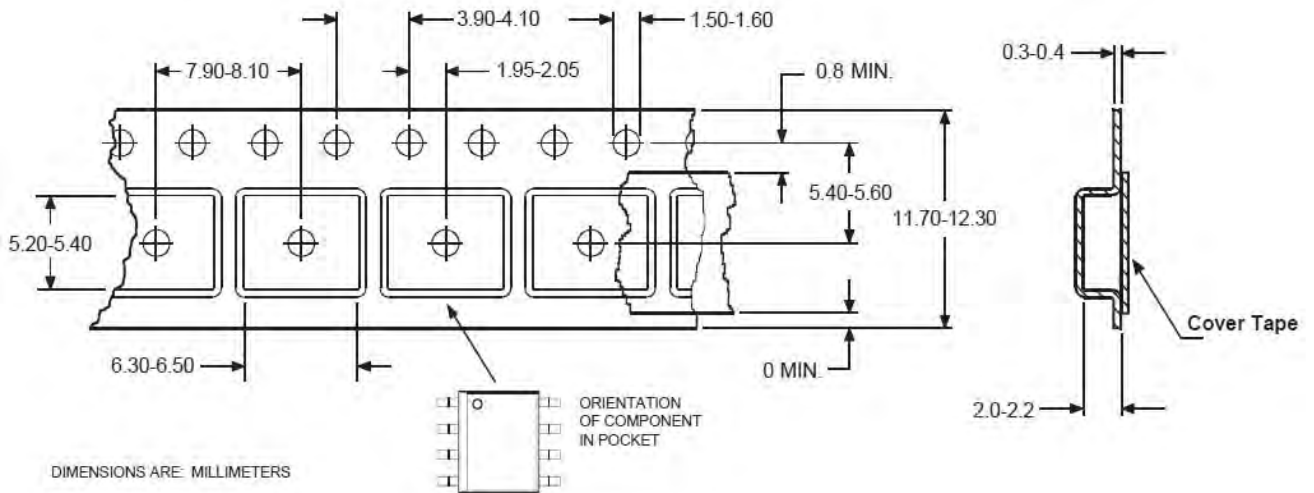

Package Type	Quantity
SOP-8	4000

X-ON Electronics

Largest Supplier of Electrical and Electronic Components

Click to view similar products for Thyristor Surge Protection Devices - TSPD category:

Click to view products by Leiditech manufacturer:

Other Similar products are found below :

[MMT08B310T3](#) [BEP4200TB](#) [BS4200N-C-2](#) [P0080F](#) [P0080SB](#) [P0640SC](#) [P3100SB](#) [P0640SB](#) [B0300TB](#) [P0080FB-MC](#) [P0080SA](#)
[LM61089B](#) [P3500SC](#) [P3100SB](#) [P2300SC](#) [P0080SC](#) [P0640SC](#) [P0080TAL](#) [P0080LBL](#) [P0220TAL](#) [P0640SB](#) [SPD8811B-2/TR](#) [ES0640SC](#)
[P3100SCX](#) [P0080TB](#) [P3500SA](#) [P0800TA](#) [P0080SC](#) [SKKH 106/18E](#) [SKKH 162/14E](#) [SKKH 42/12E](#) [SKKH 57/16E](#) [SKKH 72/08E](#)
[NP3100SBT3G](#) [SK20NHMH10](#) [P3800FNLTP](#) [TB2300L-13-F](#) [P2300MEL](#) [TISP4030L1BJR-S](#) [P4800MEL](#) [TISP4P035L1NR-S](#)
[TISP4011H1BJR-S](#) [P2600SDLRP](#) [SKKH 280/20E H4](#) [SKKH 72/16E](#) [SKKH 72/20E H4](#) [SKKH92/16E](#) [SKKH 132/16E](#) [SKKH 172/16E](#)
[SKKH 106/16E](#)