

DESCRIPTION:

LM-Z5W37V TVS diodes can be used in sensitive electronics protection against voltage transients induced by inductive load switching and lighting, especially for automotive load dump protection application.

FEATURES:

- ✧ Available in uni/bi-directional polarity.
- ✧ Low forward voltage drop & Low leakage current.
- ✧ High surge capability.
- ✧ Junction passivation optimized design passivated anisotropic rectifier technology.
- ✧ $T_J = 175\text{ }^\circ\text{C}$ capability suitable for high reliability and automotive requirement.
- ✧ Meets ISO7637-2 surge specification (varied by test condition).
- ✧ Meets MSL level 1, per J-STD-020, LF maximum peak of $245\text{ }^\circ\text{C}$.
- ✧ AEC-Q101 qualified.
- ✧ Compliant to ROHS Directive 2002/95/EC and in accordance to WEEE 2002/96/EC

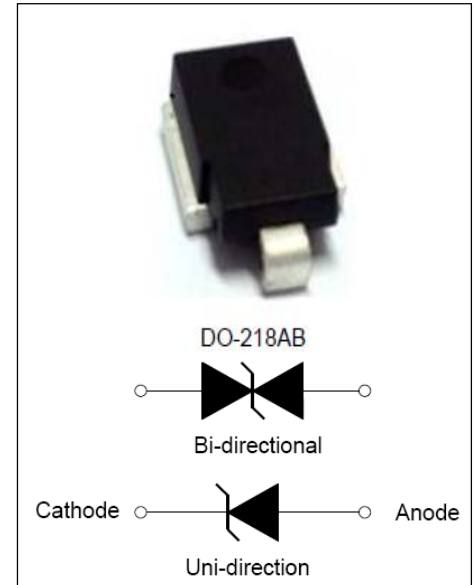

ABSOLUTE MAXIMUM RATINGS ($T_A=25^\circ\text{C}$, RH=45%-75%, unless otherwise noted)

Parameter	Symbol	Value	Unit
Peak pulse power dissipation on 10/1000us waveform	P_{pp}	3600	Watts
Peak pulse power dissipation on 10/10000us waveform		2800	Watts
Peak pulse current with 10/1000us waveform	I_{pp}	See next table	Amps
Power dissipation on infinite heat Sink at $T_C=25^\circ\text{C}$	P_D	5.0	Watts
Peak forward surge current, 8.3ms single half sine-wave	I_{FSM}	500	Amps
Operating Junction and Storage Temperature Range	T_J, T_{STG}	-55 to +150	$^\circ\text{C}$
Typical thermal resistance, junction to case	$R_{\theta JC}$	1.0	$^\circ\text{C/Watt}$

ELECTRICAL CHARACTERISTICS

Part Number	V _R	I _R @V _R		V _{BR} @ I _T		I _T	V _c @ I _{pp}	I _{pp}
		μA@25°C	μA@175°C	min(V)	max (V)			
LM-Z5W37V	33.0	5	150	36.7	40.6	5	53.3	68.0

Note:

① For all types maximum VF = 2.0 V at IF = 100 A measured on 8.3 ms single half sine-wave or equivalent square wave, duty cycle = 4 pulses per minute maximum.

②. Surge waveform: 10/1000μs

V_R : Stand-off Voltage -- Maximum voltage that can be applied

V_{BR}: Breakdown Voltage

V_C: Clamping Voltage -- Peak voltage measured across the suppressor at a specified I_{pp}

I_R: Reverse Leakage Current

I_T: Test current

Mechanical Data

CASE: DO-218AB Molding compound meets UL 94V-0 flammability rating Base P/NHE3-ROHS-compliant, AEC-Q101 qualified.

Terminals: Matte tin plated leads, solder able per J-STD-002 and JESD 22-B102, HE3 suffix meets JESD 201 class 2 whisker tests.

RATINGS AND CHARACTERISTICS CURVES ($T_A=25^\circ\text{C}$, unless otherwise noted)

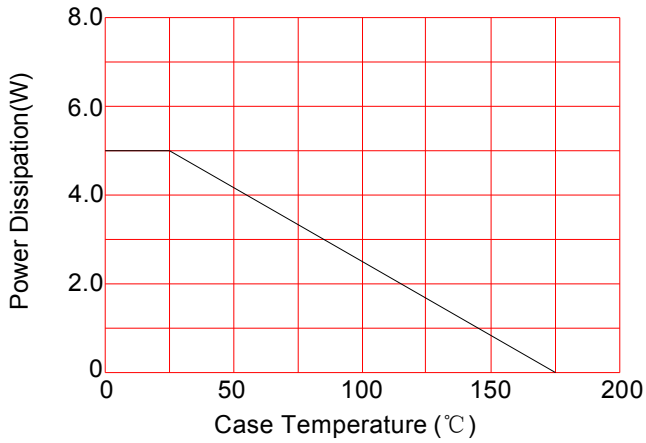

FIG.1: Power Derating Curve

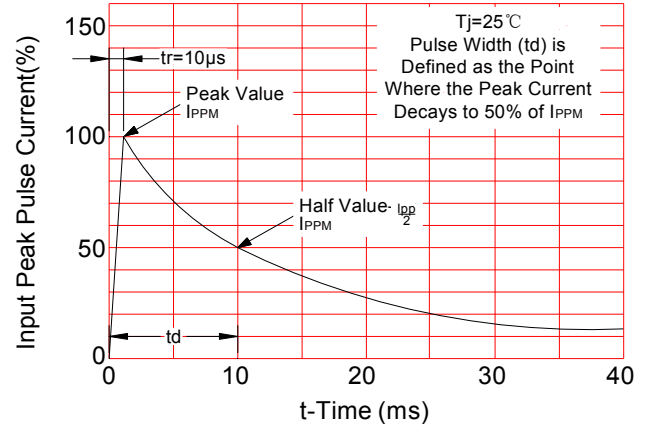

FIG.2: Pulse Waveform

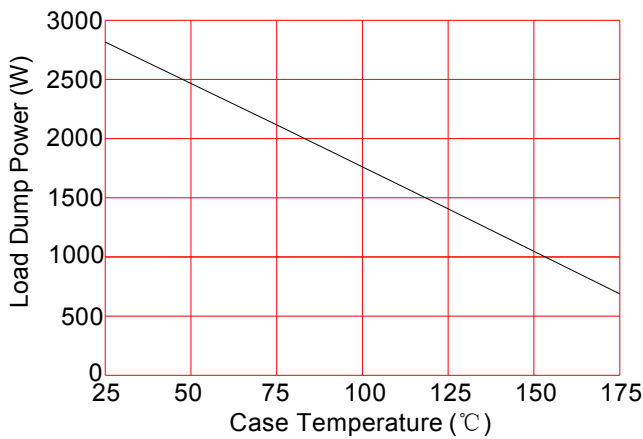

FIG.3: Load Dump Power Characteristics (10ms Exponential Waveform)

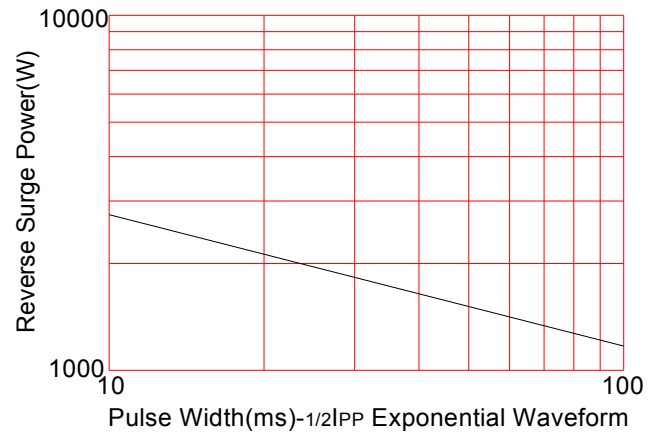

FIG.4: Reverse Power Capability

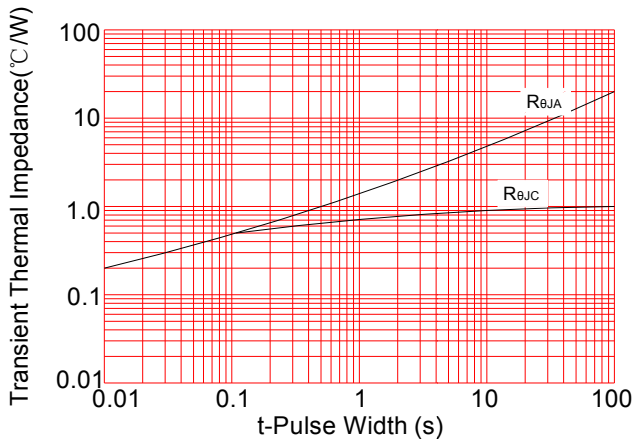
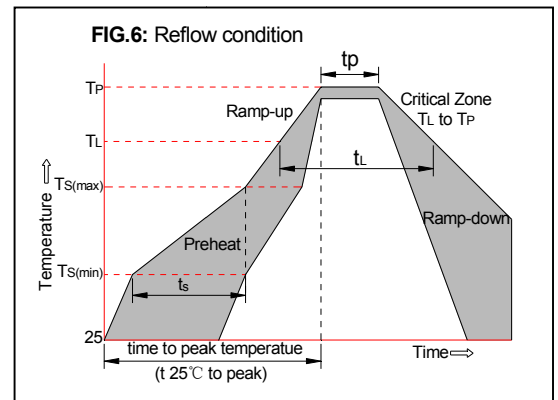

FIG.5: Typical Transient Thermal Impedance

SOLDERING PARAMETERS

Reflow Condition		Pb-Free assembly (see FIG.5)
Pre Heat	-Temperature Min ($T_{s(min)}$)	+150°C
	-Temperature Max($T_{s(max)}$)	+200°C
	-Time (Min to Max) (ts)	60-180 secs.
Average ramp up rate (Liquid us Temp (T_L) to peak)		3°C/sec. Max
$T_{s(max)}$ to T_L - Ramp-up Rate		3°C/sec. Max
Reflow	-Temperature(T_L)(Liquid us)	+217°C
	-Temperature(t_L)	60-150 secs.
Peak Temp (T_p)		+260(+0/-5)°C
Time within 5°C of actual Peak Temp (t_p)		30 secs. Max
Ramp-down Rate		6°C/sec. Max
Time 25°C to Peak Temp (T_p)		8 min. Max
Do not exceed		+260°C



PACKAGE MECHANICAL DATA

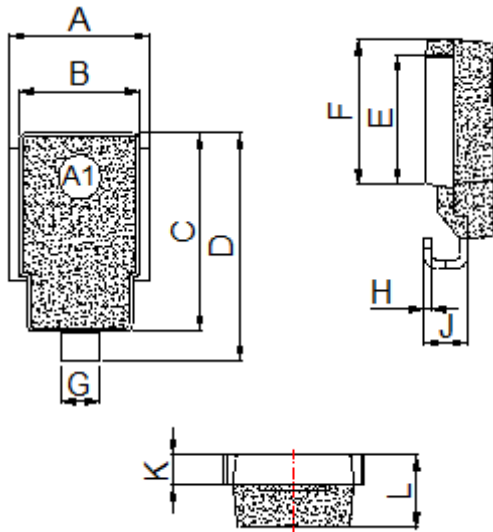

Dimension	Inches		Millimeters	
	Min	Max	Min	Max
A	0.374	0.413	9.5	10.5
B	0.327	0.342	8.3	8.7
C	0.524	0.539	13.3	13.7
D	0.592	0.628	15.0	16.0
E	0.335	0.358	8.5	9.1
F	0.374	0.398	9.5	10.1
G	0.094	0.118	2.4	3.0
H	0.020	0.028	0.5	0.7
J	0.106	0.146	2.7	3.7
K	0.075	0.083	1.9	2.1
L	0.185	0.201	4.7	5.1

TAPE AND REEL SPECIFICATION-DO-218AB

Spec No: _____

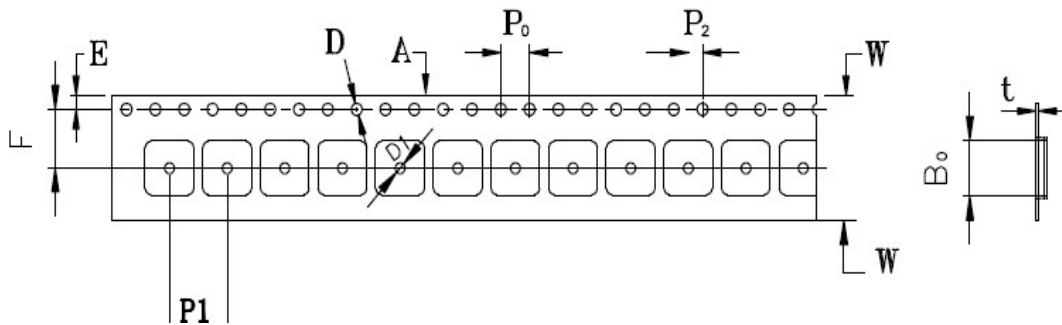

ITEM	W	A0	B0	K0	K1	P1	E	F	D	D1	P0	P2	T
DIM	24mm	10.8mm	16.13mm	5.21mm	3.9mm	16mm	1.75mm	11.5mm	1.55mm	1.55mm	4.0mm	2.0mm	0.4mm
TOL	±0.1	±0.1	±0.1	±0.1	±0.1	±0.1	±0.1	±0.1	±0.1	±0.1	±0.1	±0.1	±0.1

Note:

- 10 pocket holes pitch cumulative tolerance ±0.20mm.
- Carrier camber is 1mm in 100mm.
- A0 and B0 are measured on a plane 0.30mm above the bottom of the pocket.
- K0 is measured from a plane on the inside bottom of the pocket to the top surface of the pocket.
- All dimensions meet EIA-481-2-A requirements.
- Packing length per 22" Reel: 205Meters.

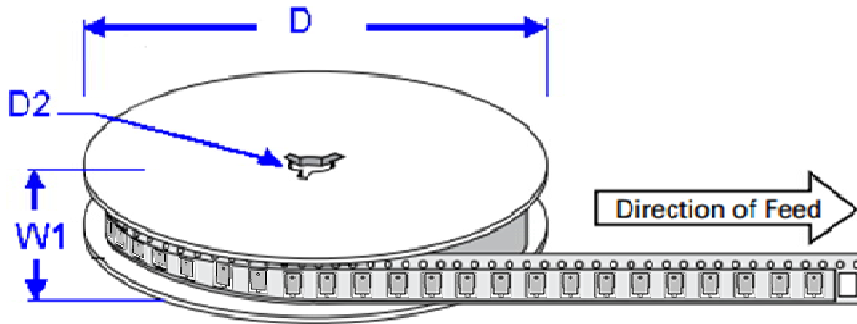

Dimensions	millimeters	inches
D	330 ± 0.2	13.0 ± 0.008
D2	13.2 ± 0.2	0.52 ± 0.008
W1	24 ± 0.2	0.94 ± 0.008

OUTLINE	REEL (PCS)	PER CARTON (PCS)	REEL DIAMETERS (mm)
TAPING	750	3000	330

NOTICE

Leiditech reserves the right to make modifications, enhancements, improvements, corrections or other changes without further notice to any product herein. Leiditech does not assume any liability arising out of the application or use of any product described herein.

X-ON Electronics

Largest Supplier of Electrical and Electronic Components

Click to view similar products for [ESD Suppressors / TVS Diodes](#) category:

Click to view products by [Leiditech](#) manufacturer:

Other Similar products are found below :

[60KS200C](#) [D18V0L1B2LP-7B](#) [D5V0F4U5P5-7](#) [NTE4902](#) [P4KE27CA](#) [P6KE11CA](#) [P6KE8.2A](#) [SA60CA](#) [SA64CA](#) [SMBJ12CATR](#)
[SMBJ33CATR](#) [SMBJ6.5A](#) [SMBJ8.0A](#) [ESD101-B1-02ELS](#) [E6327](#) [ESD112-B1-02EL](#) [E6327](#) [ESD7451N2T5G](#) [19180-510](#) [CPDT-5V0USP-](#)
[HF](#) [3.0SMCJ33CA-F](#) [3.0SMCJ36A-F](#) [HSPC16701B02TP](#) [JANTX1N6126A](#) [D3V3Q1B2DLP3-7](#) [D55V0M1B2WS-7](#) [SCM1293A-04SO](#)
[ESD200-B1-CSP0201](#) [E6327](#) [SM12-7](#) [CEN955](#) [W/DATA](#) [VESD12A1A-HD1-GS08](#) [CPDQC5V0-HF](#) [D1213A-01LP4-7B](#) [ESD101-B1-02EL](#)
[E6327](#) [AOZ8808DI-03](#) [5KP15A](#) [5KP48A](#) [5KP90A](#) [ESD3V3D7-TP](#) [15KPA36A-LF](#) [P4KE56CA](#) [P4KE68A](#) [P4KE91CATR](#) [P6KE120A](#)
[P6KE13CA](#) [P6KE43CA](#) [P6KE6.8CA](#) [P6KE8.2](#) [P6SMBJ20CA](#) [JANTX1N6072A](#) [SR2835ESKG](#) [SA90CA](#)