

### 1 Feature

- Ultra-low capacitance:0.05pF(Typ.)
- Low leakage current(<10nA)
- Fast response time(<1ns)
- IEC61000-4-2(Contact) : 15KV  
IEC61000-4-2(Air) : 15KV
- Bi-directional, single line protection

### 3 Application

- HDTV/Smart TV
- Set-Top Box
- Laptop/Desktop Computer
- HDMI 、USB 3.0
- USB3.1 、Lightning 、Thunderbolt

### 5 Pin Description

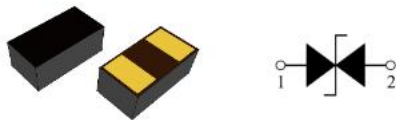

### 2 Description

LXES15AAA1-133 polymeric ESD suppressor help protect sensitive electronic equipment against electrostatic discharge (ESD) without distorting data signals. This protection is a result of its ultra-low capacitance of only 0.05 pF (I/O to GND), and it can be used to help equipment to pass IEC61000-4-2 level 4 test (15KV air, 8KV contact discharge).

**Caution:** This component is designed for signal line protection only, not intended to be used on power lines or for power bus applications.

### 4 Device Information

Model	Package	Size
PESD1542U005	0402-2	1.00 mm × 0.52 mm × 0.38 mm

### 6 General Characteristics

Parameter	Value	Unit
Contact Discharge Voltage Per IEC61000-4-2	15	KV
Air Discharge Voltage Per IEC61000-4-2	15	KV
Operating Temperature	-55 to +125	°C
Storage Temperature	-40 to +85	°C

### 7 Electrical Characteristics ( T =25°C )

Parameter	Symbol	Conditions	Min.	Typ.	Max.	Units
Continuous Operating Voltage	V <sub>DC</sub>	---	---	---	15	V
Trigger Voltage	V <sub>T</sub>	IEC61000-4-2 8KV contact discharge	---	450	---	V
Clamping Voltage	V <sub>C</sub>	IEC61000-4-2 8KV contact discharge	---	40	---	V
Leakage Current	I <sub>L</sub>	DC 18V shall be applied on component	---	---	10	nA
Capacitance	C <sub>P</sub>	Measured at 10MHz	---	0.05	---	pF
ESD Pulse Withstand	Pulses	IEC61000-4-2 8KV contact discharge	1000	---	---	---

Notes: 1.Trigger and clamping voltage are measured per IEC 61000-4-2, 8KV contact discharge method.

2.After reliability tests such as high Temp storage, Temp cycles, continuous ESD strike etc, the maximum leakage current is less than 1uA maximum leakage current is less than 1uA.

**8 Typical ESD Response ( IEC 61000-4-2, 8KV contact discharge )**

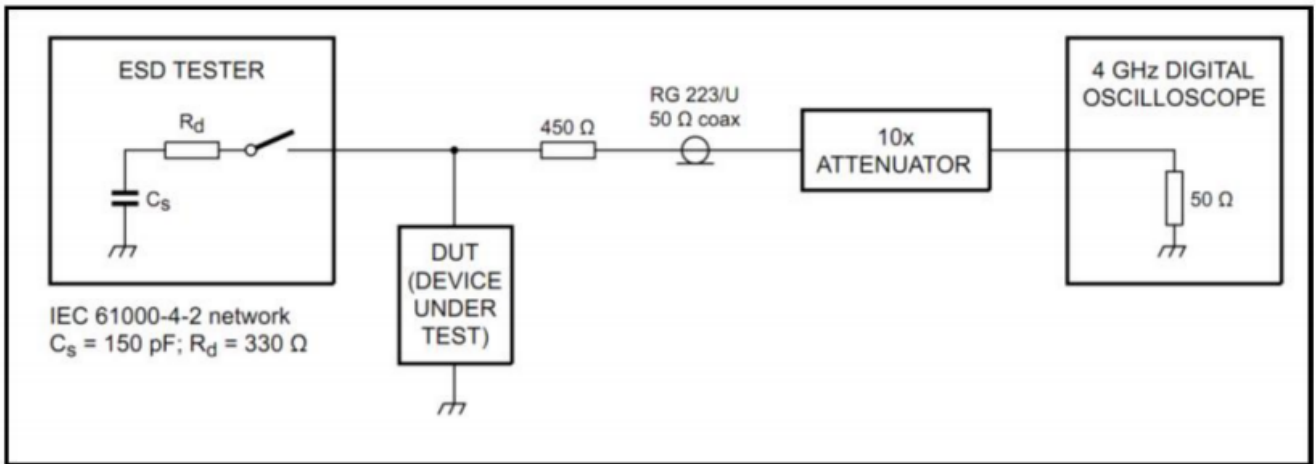

**9 Typical ESD Response ( IEC 61000-4-2, 8KV contact discharge )**

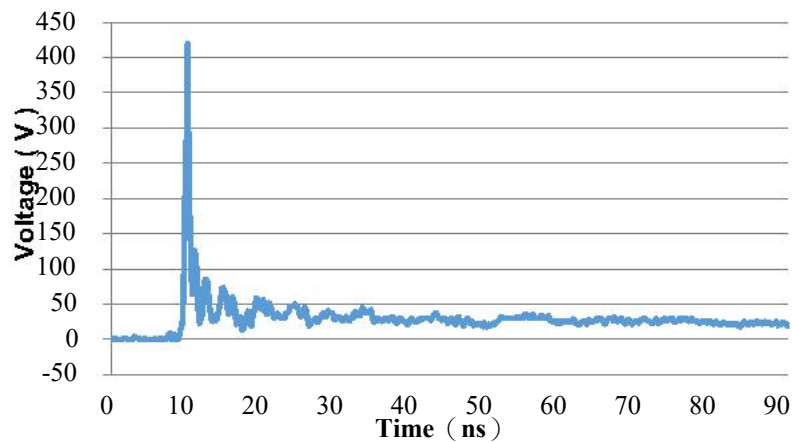

**10 Typical Device Capacitance VS. Frequency**

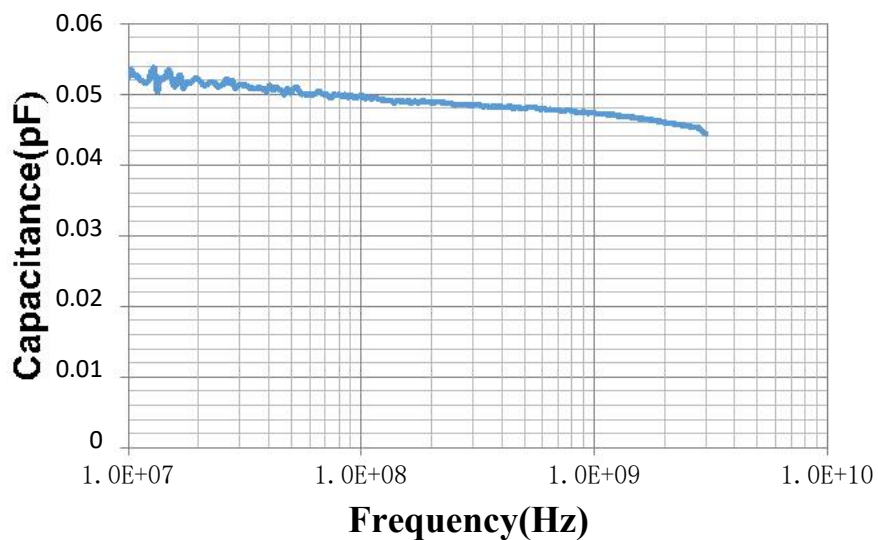

## 11 Eye Diagram Measurement

### HDMI Mask at 3.4 Gbps

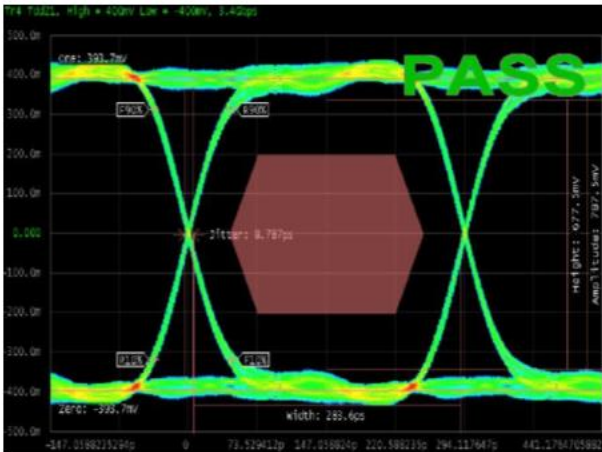

### USB3.0 Mask at 5.0 Gbps



## 12 ESD Protection for Signal Line

The PESD is designed for the protection of one bidirectional data line from ESD damage.

- Place the PESD as close to the input terminal or connector as possible.
- Minimize the path length between the PESD and the protected signal line.
- Use ground planes whenever possible.

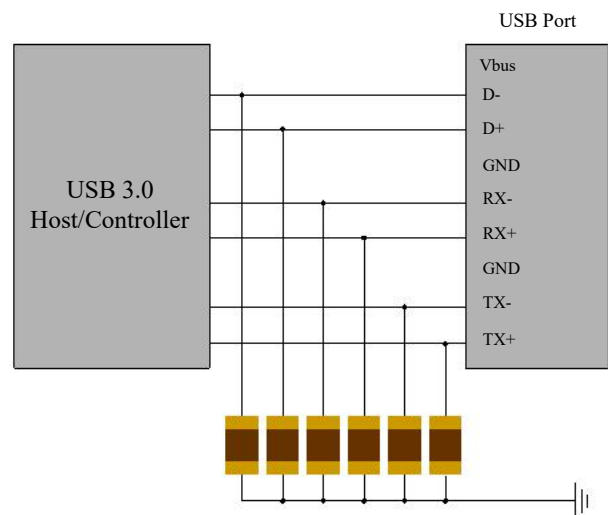
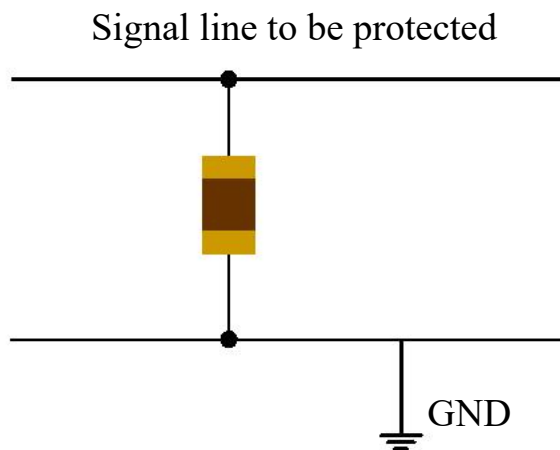

## 12 Soldering Parameters

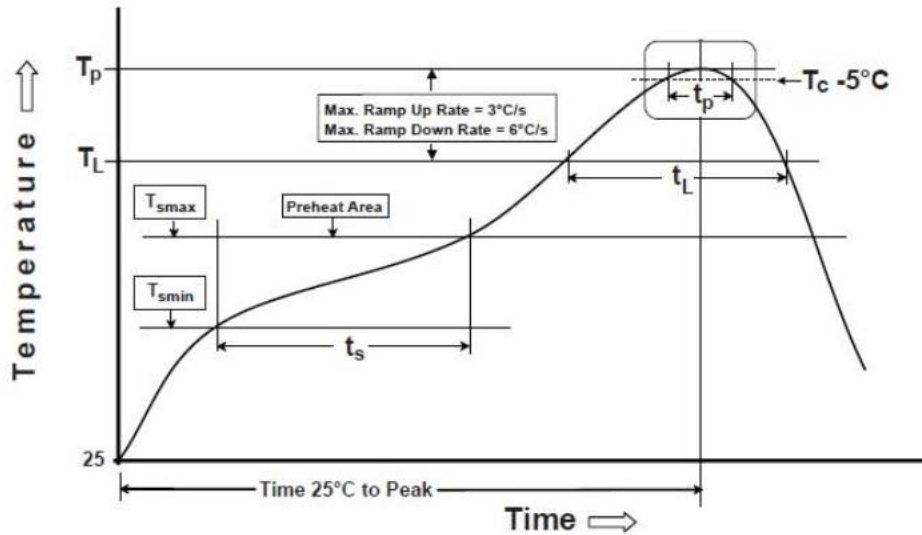

Profile Feature	Pb-Free Assembly
Pre Heat	
Temperature Min ( $T_{smin}$ )	150 °C
Temperature Max ( $T_{smax}$ )	200 °C
Time ( $t_s$ ) from ( $T_{smin}$ to $T_{smax}$ )	60-120 seconds
Ramp-up Rate ( $T_L$ to $T_p$ )	3 °C/second max.
Liquidus temperature ( $T_L$ )	217 °C
Time ( $t_L$ ) maintained above $T_L$	60-150 seconds
Peak package body temperature ( $T_p$ )	260 °C
Time ( $t_p$ )* within 5 °C of the specified classification temperature ( $T_c$ )	$+0/-5$ 30* seconds
Ramp-down Rate ( $T_p$ to $T_L$ )	6 °C/second max.
Time 25 °C to peak temperature	8 minutes max.
* Tolerance for peak profile temperature ( $T_p$ ) is defined as a supplier minimum and a user maximum.	

0402-2 Package

13 Package Dimension

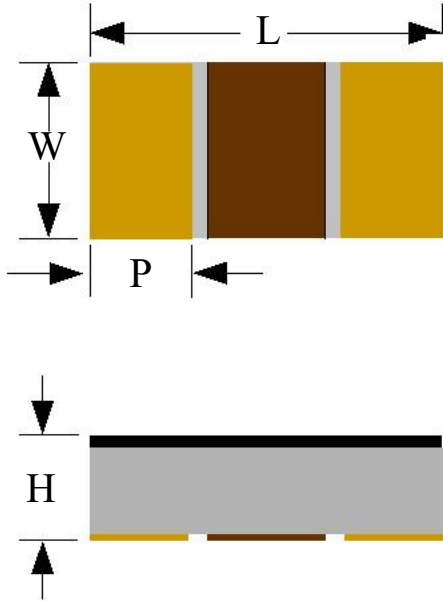

Recommended Solder Pad Footprint

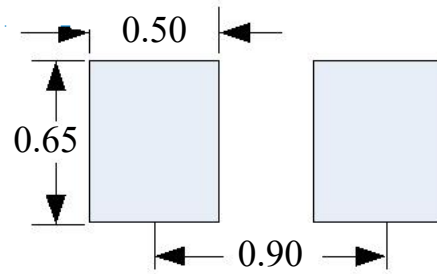

\*Sizes in mm

Notes :

This solder pad layout is for reference purposes only.

Dimension	Unit: Millimeters		
	Min.	Typ.	Max.
L	0.90	1.00	1.10
W	0.42	0.52	0.62
P	0.15	0.25	0.35
H	0.25	0.38	0.45

14 Taping Specification

Unit: Millimeters

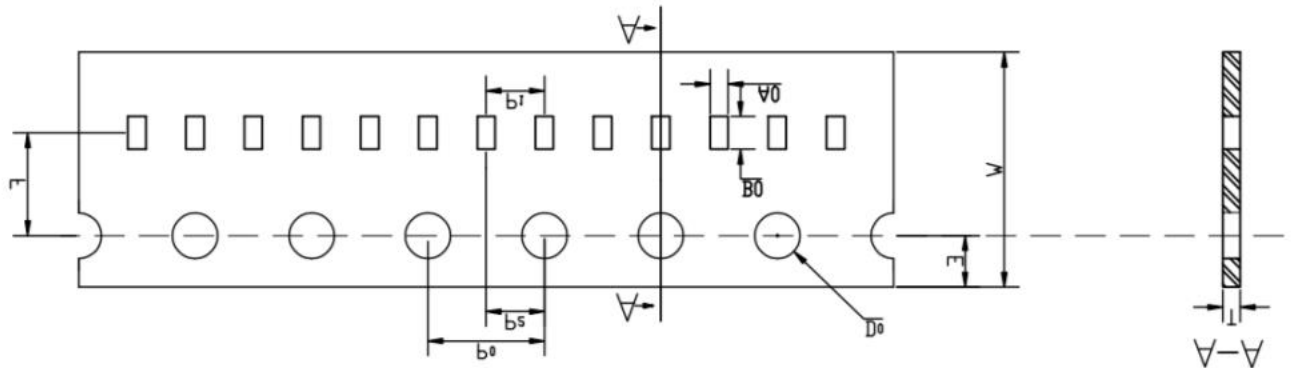

A <sub>0</sub>	B <sub>0</sub>	W	F	E	P <sub>1</sub>	P <sub>2</sub>	P <sub>0</sub>	D <sub>0</sub>	T
0.68±0.03	1.17±0.03	8.00±0.10	3.50±0.05	1.75±0.10	2.00±0.05	2.00±0.05	4.00±0.10	1.55±0.05	0.43±0.03

Reel Dimension

Unit: Millimeters

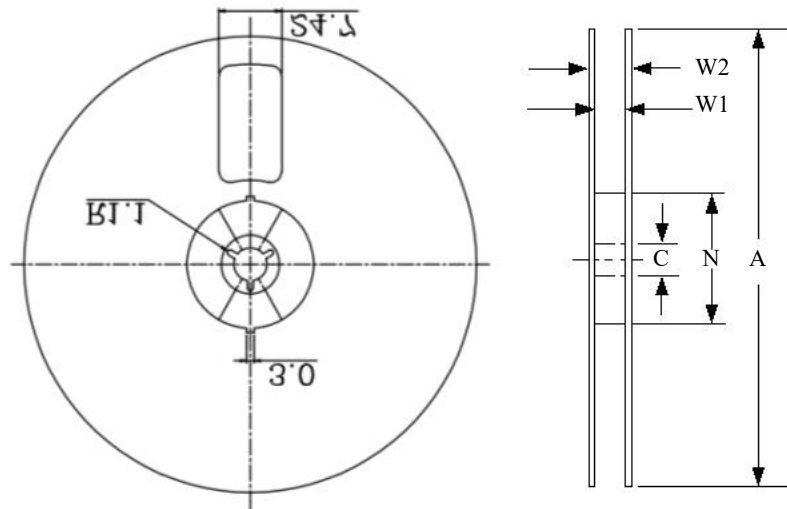

A	N Min.	C	W2 Max.	W1 Min.	W1 Max.
178.0±2.0	50.0	13.0±0.2	14.4	8.4	9.9

## 15 Ordering & Contact Information

Ordering Code	Package	Net Weight	Delivery Form	Delivery Quantity
LXES15AAA1-133	0402-2	0.62 mg / 1 pce	Mini T&R (7")	10,000 pcs/reel

## X-ON Electronics

Largest Supplier of Electrical and Electronic Components

*Click to view similar products for [ESD Suppressors / TVS Diodes](#) category:*

*Click to view products by [Leiditech](#) manufacturer:*

Other Similar products are found below :

[60KS200C](#) [D18V0L1B2LP-7B](#) [D5V0F4U5P5-7](#) [NTE4902](#) [P4KE27CA](#) [P6KE11CA](#) [P6KE8.2A](#) [SA60CA](#) [SA64CA](#) [SMBJ12CATR](#)  
[SMBJ33CATR](#) [SMBJ6.5A](#) [SMBJ8.0A](#) [ESD101-B1-02ELS](#) [E6327](#) [ESD112-B1-02EL](#) [E6327](#) [ESD7451N2T5G](#) [19180-510](#) [CPDT-5V0USP-](#)  
[HF](#) [3.0SMCJ33CA-F](#) [3.0SMCJ36A-F](#) [HSPC16701B02TP](#) [JANTX1N6126A](#) [D3V3Q1B2DLP3-7](#) [D55V0M1B2WS-7](#) [SCM1293A-04SO](#)  
[ESD200-B1-CSP0201](#) [E6327](#) [SM12-7](#) [CEN955](#) [W/DATA](#) [VESD12A1A-HD1-GS08](#) [CPDQC5V0-HF](#) [D1213A-01LP4-7B](#) [ESD101-B1-02EL](#)  
[E6327](#) [AOZ8808DI-03](#) [5KP15A](#) [5KP48A](#) [5KP90A](#) [ESD3V3D7-TP](#) [15KPA36A-LF](#) [P4KE56CA](#) [P4KE68A](#) [P4KE91CATR](#) [P6KE120A](#)  
[P6KE13CA](#) [P6KE43CA](#) [P6KE6.8CA](#) [P6KE8.2](#) [P6SMBJ20CA](#) [JANTX1N6072A](#) [SR2835ESKG](#) [SA90CA](#)