

Description

P0060~P3500SA_B_C Series are low capacitance devices designed to protect broadband equipment such as VOIP, DSL modems and DSLAMs from damaging overvoltage transients.

The series provides a surface mount solution that enables equipment to comply with global regulatory standards while limiting the impact to broadband signals.



Features and Benefits

- Low voltage overshoot
- Low on-state voltage
- Does not degrade with use
- Fails short circuit when surged in excess of ratings
- Low Capacitance

Applicable Global Standards

- TIA-968-A
- ITU K.20/21 Enhanced level*
- ITU K.20/21 Basic Level
- GR 1089 Inter building*
- GR 1089 Inter building
- IEC 6100-4-5
- YD/T 1082
- YD/T 993
- YD/T 950

Electrical Characteristics

Part Number	V _{DRM} @ I _{DRM} =5μA	V _S @ 100V/μS	V _T @ I _T =2.2Amps	I _S	I _T	I _H	Capacitance @1MHz, 2V bias	
	V min	V max	V max	mA max	A max	mA min	pF min	pF max
P0060SA	6	25	4	800	2.2	50	25	150
P0080SA	6	25	4	800	2.2	50	25	150
P0220SA	15	32	4	800	2.2	50	25	150
P0300SA	25	40	4	800	2.2	50	15	140
P0640SA	58	77	4	800	2.2	150	40	60
P0720SA	65	88	4	800	2.2	150	35	60
P0900SA	75	98	4	800	2.2	150	25	55
P1100SA	90	130	4	800	2.2	150	30	50
P1300SA	120	160	4	800	2.2	150	25	45
P1500SA	140	180	4	800	2.2	150	25	45
P1800SA	170	220	4	800	2.2	150	25	50
P2300SA	190	260	4	800	2.2	150	30	50
P2600SA	220	300	4	800	2.2	150	25	50
P3100SA	275	350	4	800	2.2	150	20	45
P3500SA	320	400	4	800	2.2	150	20	45

Electrical Characteristics

Part Number	V _{DRM} @ I _{DRM} =5μA	V _S @ 100V/μS	V _T @ I _T =2.2Amps	I _S	I _T	I _H	Capacitance @1MHz, 2V bias	
	V min	V max	V max	mA max	A max	mA min	pF min	pF max
P0060SB	6	15	4	800	2.2	50	25	80
P0080SB	6	25	4	800	2.2	50	25	80
P0220SB	15	32	4	800	2.2	50	25	100
P0300SB	25	40	4	800	2.2	50	15	140
P0640SB	58	77	4	800	2.2	150	40	80
P0720SB	65	88	4	800	2.2	150	35	75
P0900SB	75	98	4	800	2.2	150	35	70
P1100SB	90	130	4	800	2.2	150	30	70
P1300SB	120	160	4	800	2.2	150	25	70
P1500SB	140	180	4	800	2.2	150	25	70
P1800SB	170	220	4	800	2.2	150	25	70
P2300SB	190	260	4	800	2.2	150	20	70
P2600SB	220	300	4	800	2.2	150	25	70
P3100SB	275	350	4	800	2.2	150	20	65
P3500SB	320	400	4	800	2.2	150	20	55

Part Number	V _{DRM} @ I _{DRM} =5μA	V _S @ 100V/μS	V _T @ I _T =2.2Amps	I _S	I _T	I _H	Capacitance @1MHz, 2V bias	
	V min	V max	V max	mA max	A max	mA min	pF min	pF max
P0060SC	6	15	4	800	2.2	50	45	100
P0080SC	6	25	4	800	2.2	50	45	100
P0220SC	15	32	4	800	2.2	50	30	110
P0300SC	25	40	4	800	2.2	50	25	80
P0640SC	58	77	4	800	2.2	150	55	155
P0720SC	65	88	4	800	2.2	150	50	150
P0900SC	75	98	4	800	2.2	150	45	140
P1100SC	90	130	4	800	2.2	150	45	115
P1300SC	120	160	4	800	2.2	150	40	115
P1500SC	140	180	4	800	2.2	150	35	110
P1800SC	170	220	4	800	2.2	150	35	110
P2000SC	180	220	4	800	2.2	150	35	120
P2300SC	190	260	4	800	2.2	150	30	120
P2600SC	220	300	4	800	2.2	150	30	120
P3100SC	275	350	4	800	2.2	150	30	110
P3500SC	320	400	4	800	2.2	150	25	110

Surge Ratings

Series	I _{PP}					ITSM 50/60 Hz	di/dt
	2x10 μs	8x20 μs	10x160 μs	10x560 μs	10x1000 μs		
	A min	A min	A min	A min	A min	A min	A/μs max
A	150	150	90	50	45	20	500
B	250	250	150	100	80	30	500
C	500	400	200	150	100	50	500

Notes:
 1 Current waveform in μs - Peak pulse current rating (I_{pp}) is repetitive and guaranteed for the life of the product.
 2 Voltage waveform in μs - I_{pp} ratings applicable over temperature range of -40°C to +85°C
 - The device must initially be in thermal equilibrium with -40°C ≤ T_j ≤ +150°C

Thermal Considerations

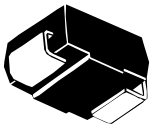
Package	Symbol	Parameter	Value	Unit
 DO-214AA	T _j	Operating Junction Temperature Range	-40 to +150	°C
	T _s	Storage Temperature Range	-65 to +150	°C
	R _{θJA}	Thermal Resistance: Junction to Ambient	90	°C/W

V-I Characteristics

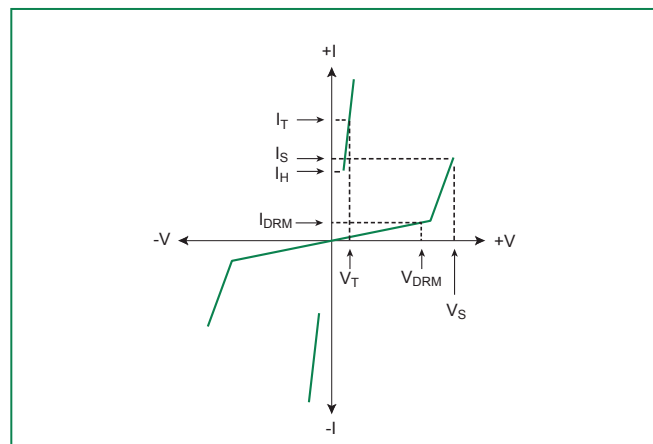

t_r x t_d Pulse Waveform

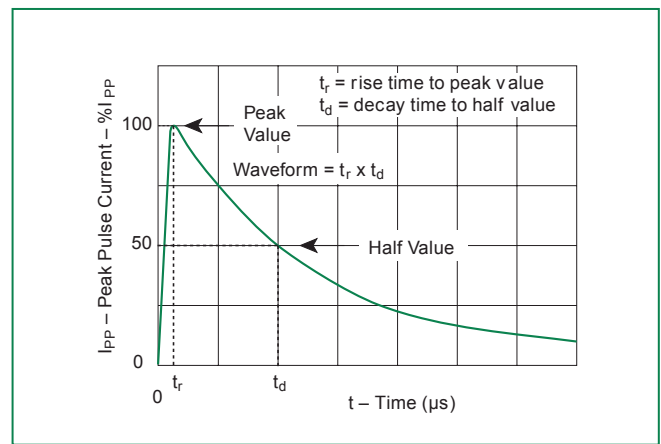

Normalized V_s Change vs. Junction Temperature

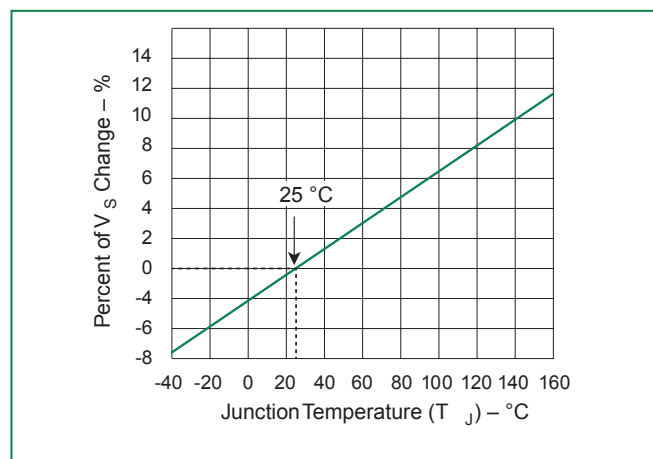

Normalized DC Holding Current vs. Case Temperature

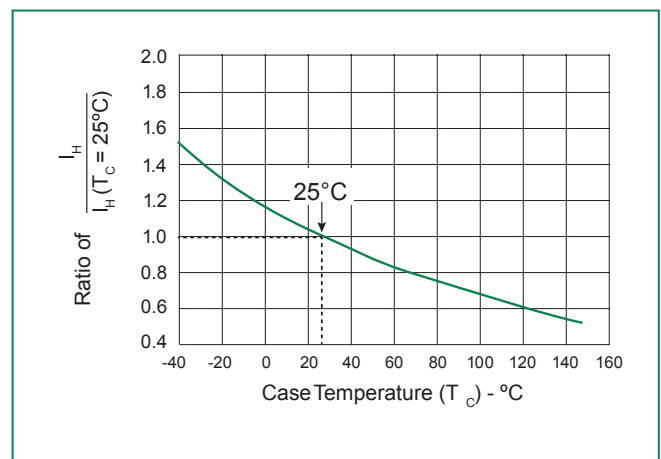
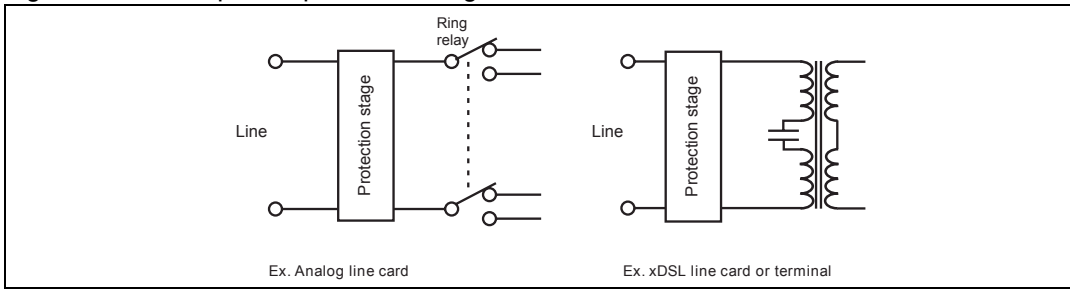

Figure 1.E examples of protection stages for line cards



In such a stage, parallel function is assumed by one or several Trisil, and is used to protect against short duration surge (lightning). During this kind of surges the Trisil limits the voltage across the device to be protected at its break over value and then fires. The fuse assumes the series function, and is used to protect the module against long duration or very high current mains disturbances (50/60Hz). It acts by safe circuit opening. Lightning surge and mains disturbance surges are defined by standards like GR1089, FCC part 68, ITU-T K20.

Figure 2. Typical circuits

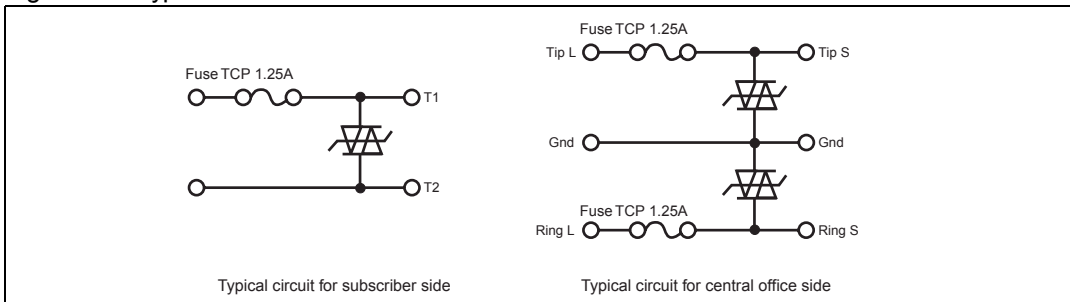

Figure 3.T est circuit 1 for Dynamic I_{BO} and V_{BO} parameters

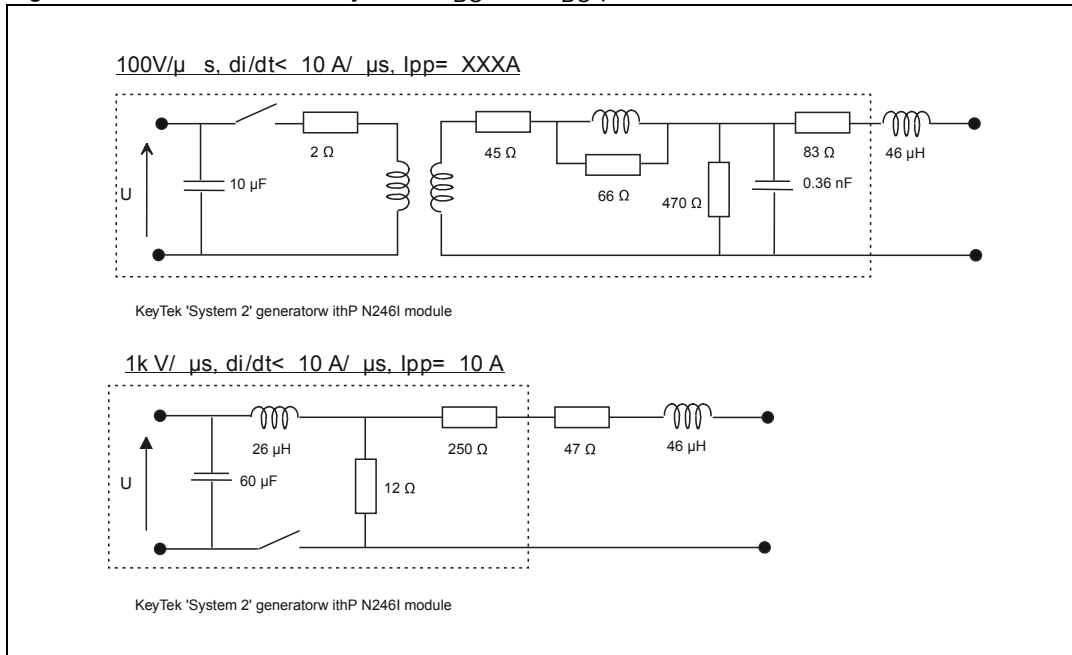

Figure 4. Test circuit 2 for I_{BO} and V_{BO} parameters

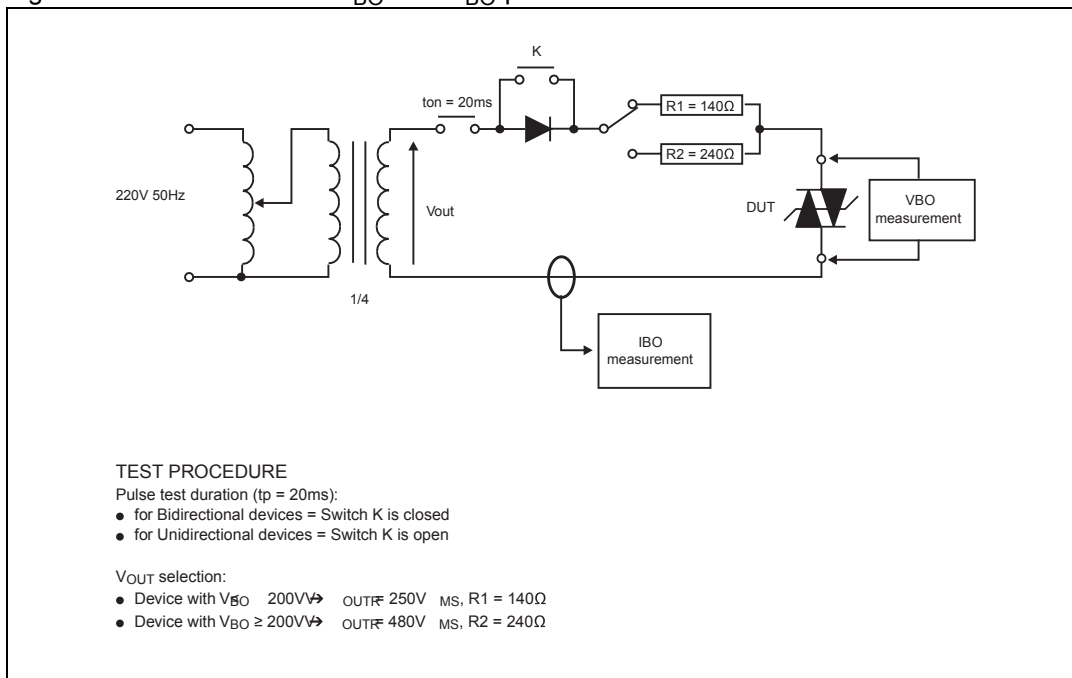
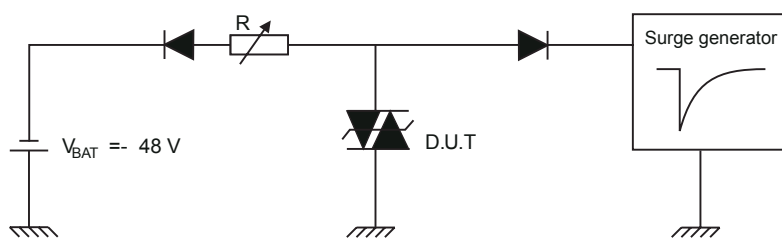

Figure 5. Test circuit 3 for dynamic I_H parameter



This is a GO-NOGO test which allows to confirm the holding current (I_H) level in a functional test circuit.

TEST PROCEDURE

- 1/ Adjust the current level at the I_H value by short circuiting the AK of the D.U.T.
- 2/ Fire the D.U.T. with a surge current $\rightarrow I_{PP} = 10A, 10/1000\mu s$.
- 3/ The D.U.T. will come back off-state within 50ms maximum.

Soldering Parameters

Reflow Condition	Pb-Free assembly (see Fig. 1)	
Pre Heat	- Temperature Min ($T_{s(min)}$)	+150°C
	- Temperature Max ($T_{s(max)}$)	+200°C
	- Time (Min to Max) (t_s)	60-180 secs.
Average ramp up rate (Liquidus Temp (T_L) to peak)	3°C/sec. Max.	
$T_{S(max)}$ to T_L - Ramp-up Rate	3°C/sec. Max.	
Reflow	- Temperature (T_L) (Liquidus)	+217°C
	- Temperature (t_L)	60-150 secs.
Peak Temp (T_p)	+260(+0/-5)°C	
Time within 5°C of actual Peak Temp (t_p)	30 secs. Max.	
Ramp-down Rate	6°C/sec. Max.	
Time 25°C to Peak Temp (T_p)	8 min. Max.	
Do not exceed	+260°C	

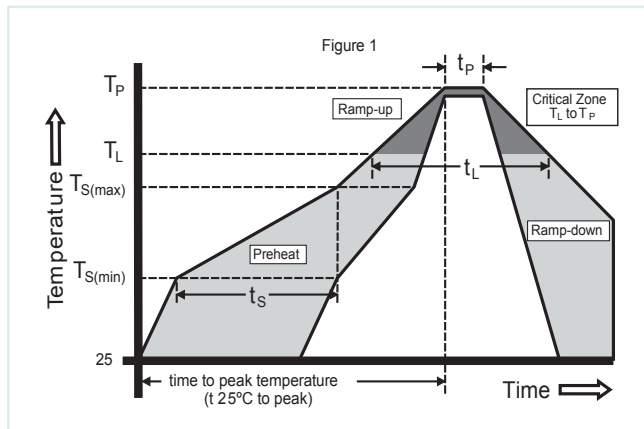

Physical Specifications

Lead Material	Copper Alloy
Terminal Finish	100% Matte-Tin Plated
Body Material	UL recognized epoxy meeting flammability classification 94V-0

Environmental Specifications

High Temp Voltage Blocking	80% Rated V_{DRM} (V_{AC} Peak) +125°C or +150°C, 504 or 1008 hrs. MIL-STD-750 (Method 1040) JEDEC, JESD22-A-101
Temp Cycling	-65°C to +150°C, 15 min. dwell, 10 up to 100 cycles. MIL-STD-750 (Method 1051) EIA/JEDEC, JESD22-A104
Biased Temp & Humidity	52 V_{DC} (+85°C) 85%RH, 504 up to 1008 hrs. EIA/JEDEC, JESD22-A-101
High Temp Storage	+150°C 1008 hrs. MIL-STD-750 (Method 1031) JEDEC, JESD22-A-101
Low Temp Storage	-65°C, 1008 hrs.
Thermal Shock	0°C to +100°C, 5 min. dwell, 10 sec. transfer, 10 cycles. MIL-STD-750 (Method 1056) JEDEC, JESD22-A-106
Autoclave (Pressure Cooker Test)	+121°C, 100%RH, 2atm, 24 up to 168 hrs. EIA/JEDEC, JESD22-A-102
Resistance to Solder Heat	+260°C, 30 secs. MIL-STD-750 (Method 2031)
Moisture Sensitivity Level	85%RH, +85°C, 168 hrs., 3 reflow cycles (+260°C Peak). JEDEC-J-STD-020, Level 1

Dimensions

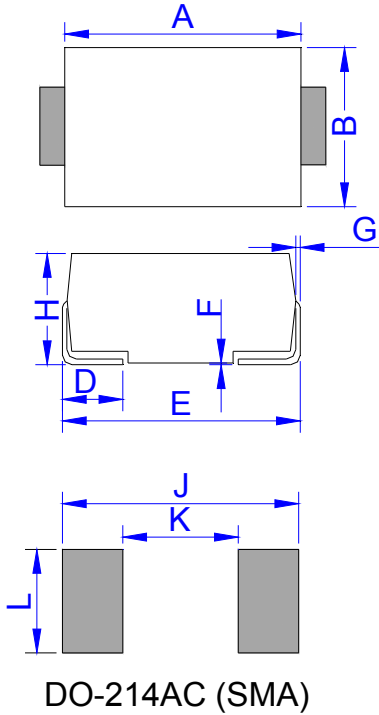

Ref.	Dimensions			
	Millimeters		Inches	
	Min.	Max.	Min.	Max.
A	4.25	4.65	0.167	0.183
B	2.50	2.90	0.098	0.114
C	1.35	1.65	0.053	0.065
D	0.76	1.52	0.030	0.060
E	4.93	5.28	0.194	0.208
F	0.051	0.203	0.002	0.008
G	0.15	0.31	0.006	0.012
H	1.98	2.41	0.078	0.095
J	6.50		0.256	
K		2.30		0.090
L	1.70		0.067	

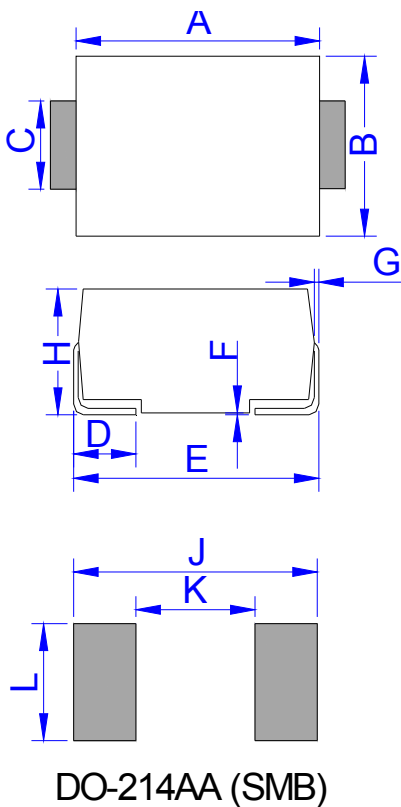

Ref.	Dimensions			
	Millimeters		Inches	
	Min.	Max.	Min.	Max.
A	4.25	4.75	0.167	0.187
B	3.30	3.94	0.130	0.155
C	1.85	2.21	0.073	0.087
D	0.76	1.52	0.030	0.060
E	5.08	5.59	0.200	0.220
F	0.051	0.203	0.002	0.008
G	0.15	0.31	0.006	0.012
H	2.11	2.44	0.083	0.096
J	6.80		0.270	
K		2.60		0.100
L	2.40		0.090	



Dimensions

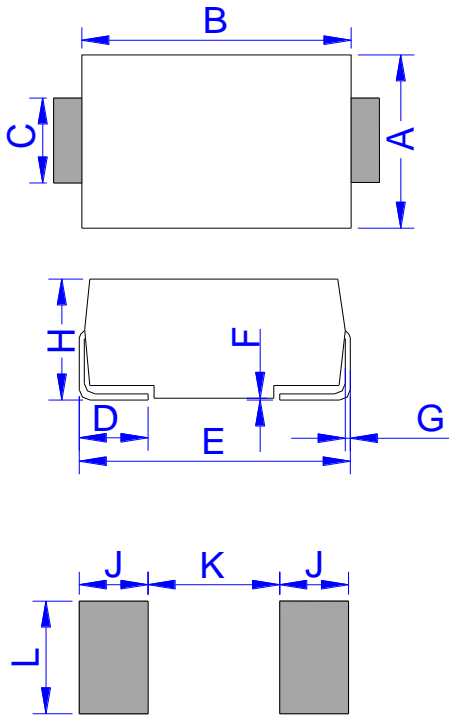

DO-214AB (SMC)

Ref.	Dimensions			
	Millimeters		Inches	
	Min.	Max.	Min.	Max.
A	5.75	6.25	0.226	0.246
B	6.90	7.40	0.272	0.291
C	2.75	3.25	0.108	0.128
D	0.95	1.52	0.037	0.060
E	7.70	8.20	0.303	0.323
F	0.051	0.203	0.002	0.008
G	0.15	0.31	0.006	0.012
H	2.15	2.62	0.085	0.103
J	2.40		0.094	
K		4.20		0.165
L	3.30		0.130	

Part Numbering

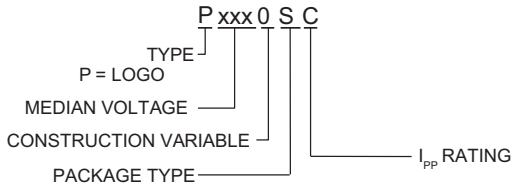

Part Marking

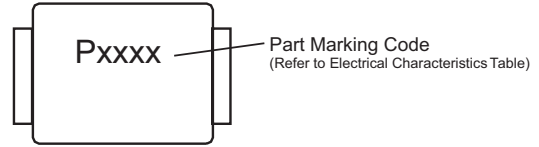

Packing Options

Package Type	Description	Quantity	Added Suffix	Industry Standard
S	DO-214AA Tape & Reel Pack	2500	N/A	EIA-481-D

Tape and Reel Specification — DO-214AA

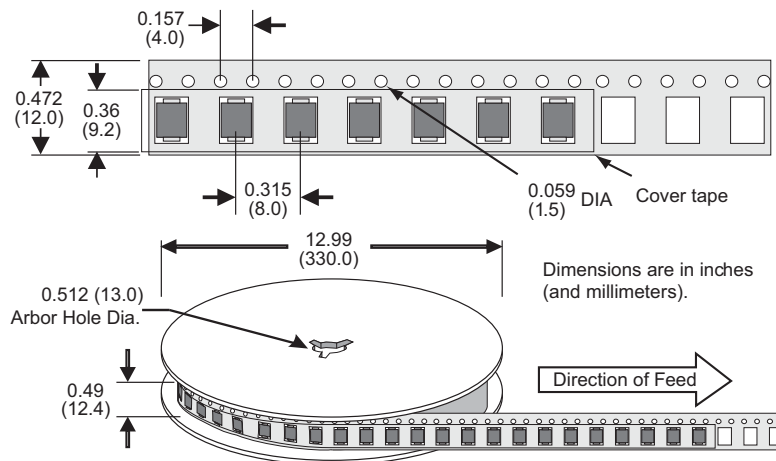

X-ON Electronics

Largest Supplier of Electrical and Electronic Components

Click to view similar products for [leiditech](#) manufacturer:

Other Similar products are found below :

[SM8S33CA](#) [LC0504F](#) [SMAJ6.5CA](#) [SBR26HD](#) [SMD4532-090NF](#) [SMAJ30CA](#) [SMCJ36CA](#) [SMBJ33CA](#) [5KP36A](#) [SMAJ40CA](#) [SMBJ40CA](#)
[ULC0504T5Q](#) [5KP36CA](#) [SMBJ7.0CA](#) [SDA12T1](#) [SMAJ18CA](#) [SR05L](#) [SM8S24CA](#) [SMBJ28CA](#) [SMF24CA](#) [SMBJ7.5CA](#) [SMC24-323](#)
[SMDA05CCN](#) [SDA3311CDN](#) [5.0SMDJ33CA](#) [ESDA0504T5](#) [SM15](#) [LC3374N](#) [SMCJ33CA](#) [SM8S33A](#) [ESD3321C](#) [SMAJ60A](#) [SDA05W5](#)
[SMAJ64CA](#) [PESD1442U005](#) [5KP33CA](#) [ESDA3.3CW-4](#) [SM24](#) [SMDJ30CA](#) [ULC052010P5](#) [ULC332010T8](#) [SMBJ22CA](#) [SM8S24A](#)
[SMDJ58CA](#) [ULC0544M](#) [SMDJ58A](#) [SM8S36A](#) [P8S33CA](#) [5.0SMDJ16CA](#) [P8S36CA](#)