

DESCRIPTION:

SM5S Series TVS diodes can be used in sensitive electronics protection against voltage transients induced by inductive load switching and lighting, especially for automotive load dump protection application.

FEATURES:

- ✧ Available in uni/bi-directional polarity.
- ✧ Low forward voltage drop & Low leakage current.
- ✧ High surge capability.
- ✧ Junction passivation optimized design passivated anisotropic rectifier technology.
- ✧ $T_J = 175\text{ }^\circ\text{C}$ capability suitable for high reliability and automotive requirement.
- ✧ Meets ISO7637-2 surge specification (varied by test condition).
- ✧ Meets MSL level 1, per J-STD-020, LF maximum peak of $245\text{ }^\circ\text{C}$.
- ✧ AEC-Q101 qualified.
- ✧ Compliant to ROHS Directive 2002/95/EC and in accordance to WEEE 2002/96/EC

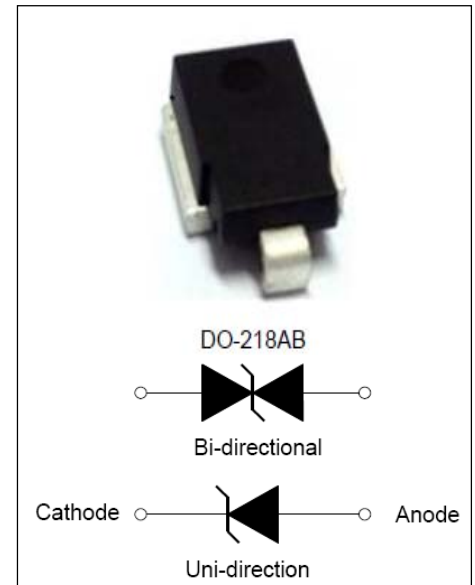

ABSOLUTE MAXIMUM RATINGS ($T_A=25^\circ\text{C}$, RH=45%-75%, unless otherwise noted)

Parameter	Symbol	Value	Unit
Peak pulse power dissipation on 10/1000us waveform	P_{pp}	3600	Watts
Peak pulse power dissipation on 10/10000us waveform		2800	Watts
Peak pulse current with 10/1000us waveform	I_{pp}	See next table	Amps
Power dissipation on infinite heat Sink at $T_C=25^\circ\text{C}$	P_D	5.0	Watts
Peak forward surge current, 8.3ms single half sine-wave	I_{FSM}	500	Amps
Operating Junction and Storage Temperature Range	T_J, T_{STG}	-55 to +150	$^\circ\text{C}$
Typical thermal resistance, junction to case	$R_{\theta JC}$	1.0	$^\circ\text{C/Watt}$

ELECTRICAL CHARACTERISTICS

Part Number		V_R	$I_R @ V_R$		$V_{BR} @ I_T$		I_T	$V_C @ I_{pp}$	I_{pp}
Uni-polar	Bi-polar	V	$\mu A @ 25^\circ C$	$\mu A @ 175^\circ C$	min(V)	max (V)	mA	V	A
SM5S10A	SM5S10CA	10.0	5	250	11.1	12.3	5	17.0	212.0
SM5S11A	SM5S11CA	11.0	5	150	12.2	13.5	5	18.2	198.0
SM5S12A	SM5S12CA	12.0	5	150	13.3	14.7	5	19.9	181.0
SM5S13A	SM5S13CA	13.0	5	150	14.4	15.9	5	21.5	167.0
SM5S14A	SM5S14CA	14.0	5	150	15.6	17.2	5	23.2	155.0
SM5S15A	SM5S15CA	15.0	5	150	16.7	18.5	5	24.4	148.0
SM5S16A	SM5S16CA	16.0	5	150	17.8	19.7	5	26.0	138.0
SM5S17A	SM5S17CA	17.0	5	150	18.9	20.9	5	27.6	130.0
SM5S18A	SM5S18CA	18.0	5	150	20.0	22.1	5	29.2	123.0
SM5S20A	SM5S20CA	20.0	5	150	22.2	24.5	5	32.4	111.0
SM5S22A	SM5S22CA	22.0	5	150	24.4	26.9	5	35.5	101.0
SM5S24A	SM5S24CA	24.0	5	150	26.7	29.5	5	38.9	93.0
SM5S26A	SM5S26CA	26.0	5	150	28.9	31.9	5	42.1	86.0
SM5S28A	SM5S28CA	28.0	5	150	31.1	34.4	5	45.4	79.0
SM5S30A	SM5S30CA	30.0	5	150	33.3	36.8	5	48.4	74.0
SM5S33A	SM5S33CA	33.0	5	150	36.7	40.6	5	53.3	68.0
SM5S36A	SM5S36CA	36.0	5	150	40.0	44.2	5	58.1	62.0

Note:

① For all types maximum VF = 2.0 V at IF = 100 A measured on 8.3 ms single half sine-wave or equivalent square wave, duty cycle = 4 pulses per minute maximum.

②. Surge waveform: 10/1000 μ s

V_R : Stand-off Voltage -- Maximum voltage that can be applied

V_{BR} : Breakdown Voltage

V_C : Clamping Voltage -- Peak voltage measured across the suppressor at a specified I_{pp}

I_R : Reverse Leakage Current

I_T : Test current

Mechanical Data

CASE: DO-218AB Molding compound meets UL 94V-0 flammability rating Base P/NHE3-ROHS-compliant, AEC-Q101 qualified.

Terminals: Matte tin plated leads, solder able per J-STD-002 and JESD 22-B102, HE3 suffix meets JESD 201 class 2 whisker tests.

ORDERING INFORMATION

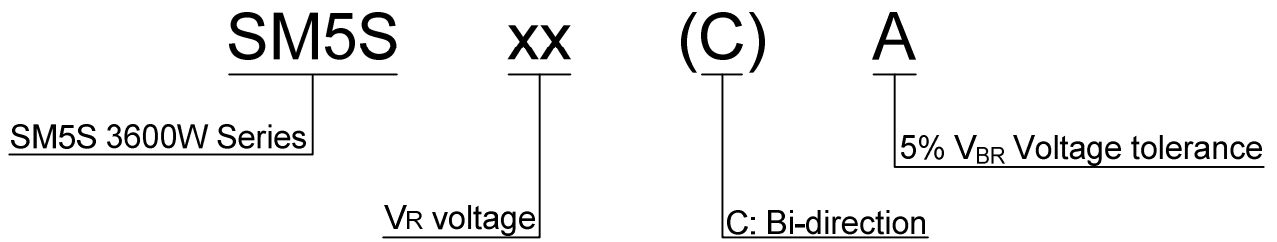

RATINGS AND CHARACTERISTICS CURVES ($T_A=25^\circ\text{C}$, unless otherwise noted)

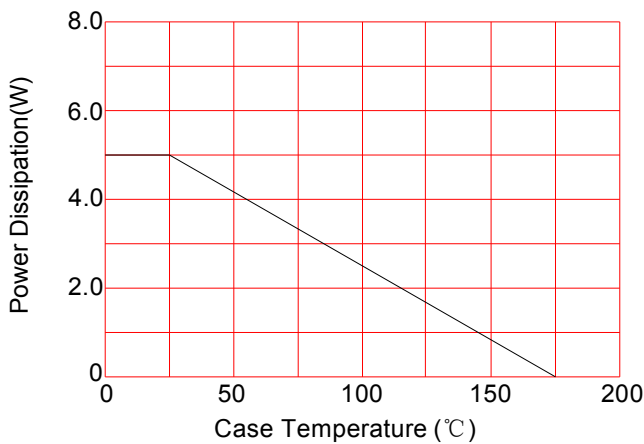

FIG.1: Power Derating Curve

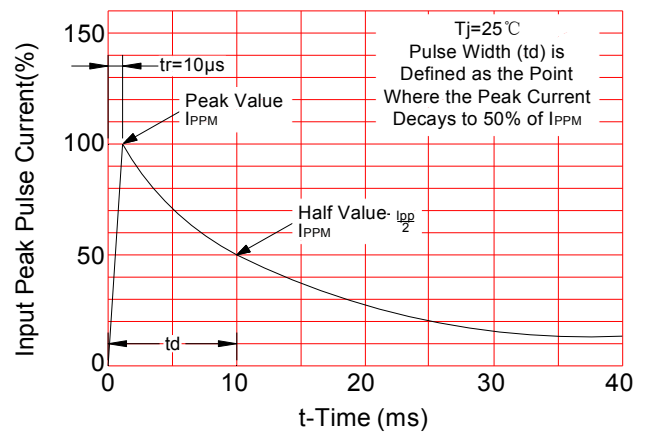

FIG.2: Pulse Waveform

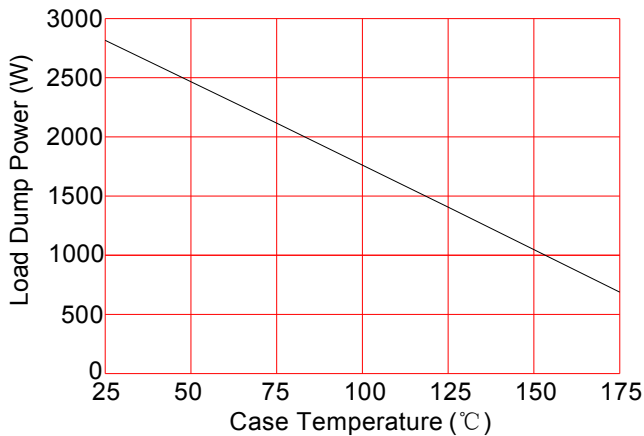

FIG.3: Load Dump Power Characteristics (10ms Exponential Waveform)

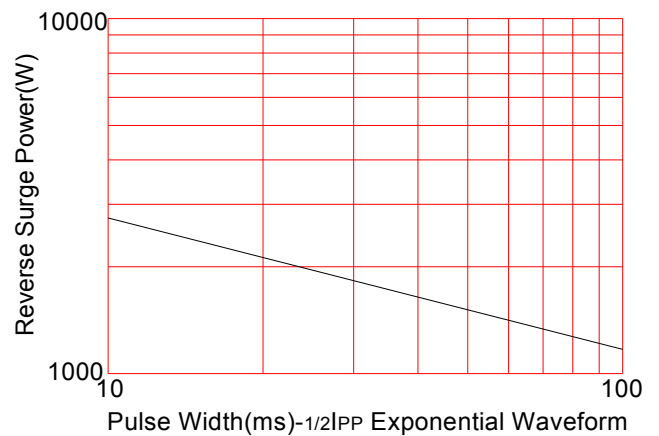

FIG.4: Reverse Power Capability

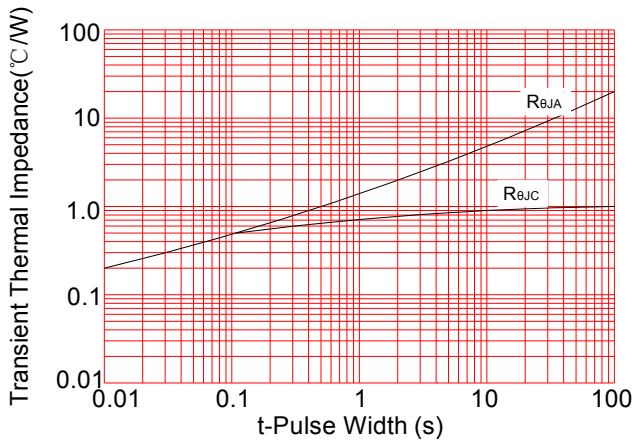
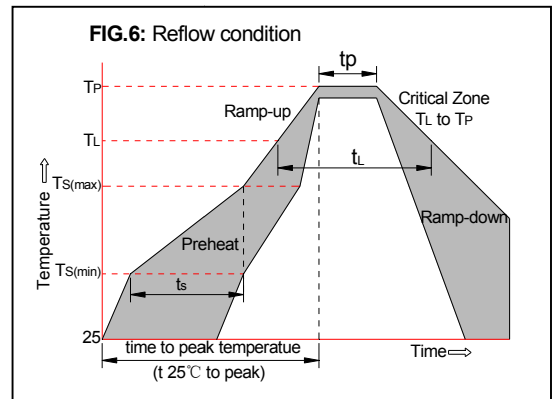

FIG.5: Typical Transient Thermal Impedance

SOLDERING PARAMETERS

Reflow Condition		Pb-Free assembly (see FIG.5)
Pre Heat	-Temperature Min ($T_{s(min)}$)	+150°C
	-Temperature Max($T_{s(max)}$)	+200°C
	-Time (Min to Max) (t_s)	60-180 secs.
Average ramp up rate (Liquid us Temp (T_L) to peak)		3°C/sec. Max
$T_{s(max)}$ to T_L - Ramp-up Rate		3°C/sec. Max
Reflow	-Temperature(T_L)(Liquid us)	+217°C
	-Temperature(t_L)	60-150 secs.
Peak Temp (T_p)		+260(+0/-5)°C
Time within 5°C of actual Peak Temp (t_p)		30 secs. Max
Ramp-down Rate		6°C/sec. Max
Time 25°C to Peak Temp (T_p)		8 min. Max
Do not exceed		+260°C



PACKAGE MECHANICAL DATA

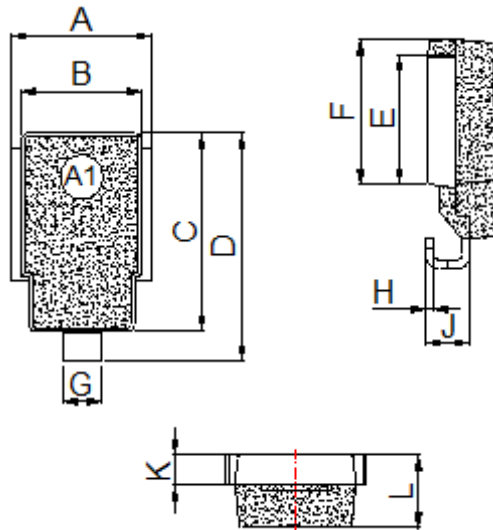

Dimension	Inches		Millimeters	
	Min	Max	Min	Max
A	0.374	0.413	9.5	10.5
B	0.327	0.342	8.3	8.7
C	0.524	0.539	13.3	13.7
D	0.592	0.628	15.0	16.0
E	0.335	0.358	8.5	9.1
F	0.374	0.398	9.5	10.1
G	0.094	0.118	2.4	3.0
H	0.020	0.028	0.5	0.7
J	0.106	0.146	2.7	3.7
K	0.075	0.083	1.9	2.1
L	0.185	0.201	4.7	5.1

TAPE AND REEL SPECIFICATION-DO-218AB

Spec No: _____

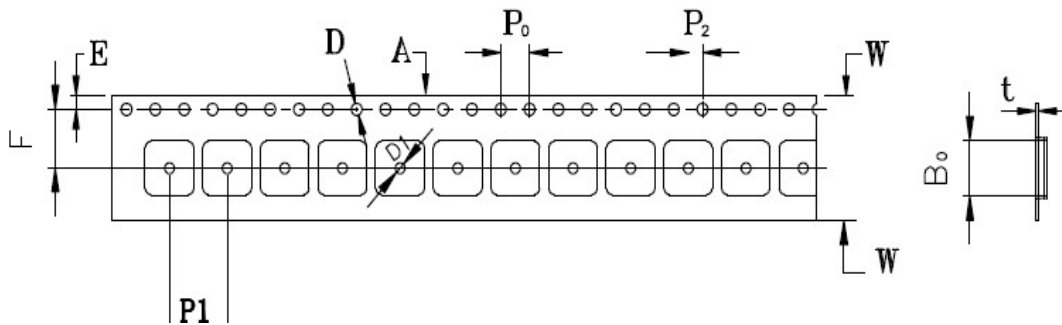

ITEM	W	A0	B0	K0	K1	P1	E	F	D	D1	P0	P2	T
DIM	24mm	10.8mm	16.13mm	5.21mm	3.9mm	16mm	1.75mm	11.5mm	1.55mm	1.55mm	4.0mm	2.0mm	0.4mm
TOL	±0.1	±0.1	±0.1	±0.1	±0.1	±0.1	±0.1	±0.1	±0.1	±0.1	±0.1	±0.1	±0.1

Note:

- 10 pocket holes pitch cumulative tolerance ± 0.20 mm.
- Carrier camber is 1mm in 100mm.
- A0 and B0 are measured on a plane 0.30mm above the bottom of the pocket.
- K0 is measured from a plane on the inside bottom of the pocket to the top surface of the pocket.
- All dimensions meet EIA-481-2-A requirements.
- Packing length per 22" Reel: 205Meters.

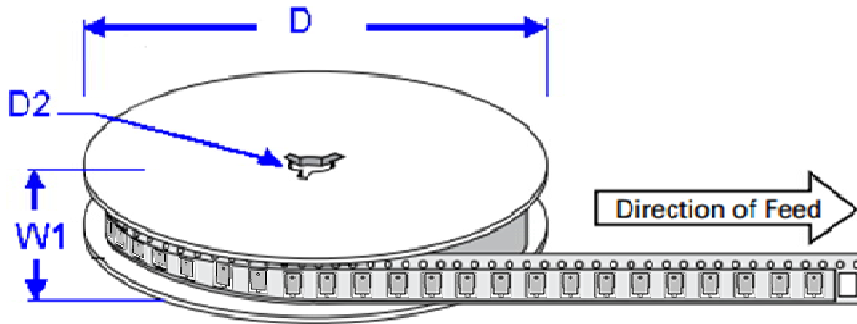

Dimensions	millimeters	inches
D	330 ± 0.2	13.0 ± 0.008
D2	13.2 ± 0.2	0.52 ± 0.008
W1	24 ± 0.2	0.94 ± 0.008

OUTLINE	REEL (PCS)	PER CARTON (PCS)	REEL DIAMETERS (mm)
TAPING	750	3000	330

X-ON Electronics

Largest Supplier of Electrical and Electronic Components

Click to view similar products for [ESD Suppressors / TVS Diodes](#) category:

Click to view products by [Leiditech](#) manufacturer:

Other Similar products are found below :

[60KS200C](#) [D18V0L1B2LP-7B](#) [D5V0F4U5P5-7](#) [NTE4902](#) [P4KE27CA](#) [P6KE11CA](#) [P6KE8.2A](#) [SA60CA](#) [SA64CA](#) [SMBJ12CATR](#)
[SMBJ33CATR](#) [SMBJ6.5A](#) [SMBJ8.0A](#) [ESD101-B1-02ELS](#) [E6327](#) [ESD112-B1-02EL](#) [E6327](#) [ESD7451N2T5G](#) [19180-510](#) [CPDT-5V0USP-](#)
[HF](#) [3.0SMCJ33CA-F](#) [3.0SMCJ36A-F](#) [HSPC16701B02TP](#) [JANTX1N6126A](#) [D3V3Q1B2DLP3-7](#) [D55V0M1B2WS-7](#) [SCM1293A-04SO](#)
[ESD200-B1-CSP0201](#) [E6327](#) [SM12-7](#) [CEN955](#) [W/DATA](#) [VESD12A1A-HD1-GS08](#) [CPDQC5V0-HF](#) [D1213A-01LP4-7B](#) [ESD101-B1-02EL](#)
[E6327](#) [AOZ8808DI-03](#) [5KP15A](#) [5KP48A](#) [5KP90A](#) [ESD3V3D7-TP](#) [15KPA36A-LF](#) [P4KE56CA](#) [P4KE68A](#) [P4KE91CATR](#) [P6KE120A](#)
[P6KE13CA](#) [P6KE43CA](#) [P6KE6.8CA](#) [P6KE8.2](#) [P6SMBJ20CA](#) [JANTX1N6072A](#) [SR2835ESKG](#) [SA90CA](#)