



RXK 系列

特长 / 用途

- 105℃、2,000 ~ 5,000小时寿命保证
- 低等效串联电阻(ESR), 适用交换式电源供应器(UPS)
- 制品尺寸较小并可承受较大之纹波电流
- 符合RoHS指令



规格表

项目	性能																																										
工作温度范围	-55℃ ~ +105℃																																										
额定静电容量容许误差值	± 20% (120Hz, 20℃)																																										
漏电流(20℃)	I = 0.01CV 或 3(μA/微安)中的任何一个较大值以下(2分钟后) I = 漏电流(μA/微安)、C = 额定静电容量(μF/微法拉)、V = 额定直流工作电压(V/伏特)																																										
损失角正切值(120Hz, 20℃)	<table border="1"> <tr> <th>额定电压</th> <td>6.3</td> <td>10</td> <td>16</td> <td>25</td> <td>35</td> <td>50</td> <td>63</td> </tr> <tr> <th>损失角正切值(最大值)</th> <td>0.22</td> <td>0.19</td> <td>0.16</td> <td>0.14</td> <td>0.12</td> <td>0.10</td> <td>0.09</td> </tr> </table> <p>当额定静电容量大于 1,000 微法拉时, 每增加 1,000 微法拉需加 0.02。</p>	额定电压	6.3	10	16	25	35	50	63	损失角正切值(最大值)	0.22	0.19	0.16	0.14	0.12	0.10	0.09																										
额定电压	6.3	10	16	25	35	50	63																																				
损失角正切值(最大值)	0.22	0.19	0.16	0.14	0.12	0.10	0.09																																				
温度特性(120Hz)	<p>阻抗比不可大于下表所列数值</p> <table border="1"> <tr> <th colspan="2">额定电压</th> <td>6.3</td> <td>10</td> <td>16</td> <td>25</td> <td>35</td> <td>50</td> <td>63</td> </tr> <tr> <th>阻抗比</th> <th>Z(-55℃)/Z(+20℃)</th> <td>4</td> <td>4</td> <td>3</td> <td>3</td> <td>3</td> <td>3</td> <td>3</td> </tr> </table>	额定电压		6.3	10	16	25	35	50	63	阻抗比	Z(-55℃)/Z(+20℃)	4	4	3	3	3	3	3																								
额定电压		6.3	10	16	25	35	50	63																																			
阻抗比	Z(-55℃)/Z(+20℃)	4	4	3	3	3	3	3																																			
耐久性	<table border="1"> <tr> <th>保证寿命时间</th> <td>φD ≦ 6.3 mm: 2,000 小时; φD = 8 mm: 3,000 小时; φD = 10 mm: 4,000 小时; φD ≧ 12.5 mm: 5,000 小时</td> </tr> <tr> <th>静电容量变化率</th> <td>≦ 初始值的 ± 20%</td> </tr> <tr> <th>损失角正切值</th> <td>≦ 初始规格值的 200%</td> </tr> <tr> <th>漏电流</th> <td>≦ 初始规格值</td> </tr> </table> <p>* 于 105℃ 环境中供给容许纹波电流值与额定电压 2,000 ~ 5,000 小时后, 待制品回复至 20℃ 的环境中进行量测时, 需满足上列要求。</p>	保证寿命时间	φD ≦ 6.3 mm: 2,000 小时; φD = 8 mm: 3,000 小时; φD = 10 mm: 4,000 小时; φD ≧ 12.5 mm: 5,000 小时	静电容量变化率	≦ 初始值的 ± 20%	损失角正切值	≦ 初始规格值的 200%	漏电流	≦ 初始规格值																																		
保证寿命时间	φD ≦ 6.3 mm: 2,000 小时; φD = 8 mm: 3,000 小时; φD = 10 mm: 4,000 小时; φD ≧ 12.5 mm: 5,000 小时																																										
静电容量变化率	≦ 初始值的 ± 20%																																										
损失角正切值	≦ 初始规格值的 200%																																										
漏电流	≦ 初始规格值																																										
高温无负荷特性	<table border="1"> <tr> <th>保证寿命时间</th> <td>1,000 小时</td> </tr> <tr> <th>静电容量变化率</th> <td>≦ 初始值的 ± 20%</td> </tr> <tr> <th>损失角正切值</th> <td>≦ 初始规格值的 200%</td> </tr> <tr> <th>漏电流</th> <td>≦ 初始规格值</td> </tr> </table> <p>* 于 105℃ 环境中不供给额定电压 1,000 小时后, 待制品回复至 20℃ 的环境中进行量测时, 需满足上列要求。</p>	保证寿命时间	1,000 小时	静电容量变化率	≦ 初始值的 ± 20%	损失角正切值	≦ 初始规格值的 200%	漏电流	≦ 初始规格值																																		
保证寿命时间	1,000 小时																																										
静电容量变化率	≦ 初始值的 ± 20%																																										
损失角正切值	≦ 初始规格值的 200%																																										
漏电流	≦ 初始规格值																																										
纹波电流与频率修正系数	<table border="1"> <tr> <th rowspan="2">频率(Hz)</th> <th colspan="7">静电容量(μF/微法拉)</th> </tr> <tr> <th>60 (50)</th> <th>120</th> <th>500</th> <th>1k</th> <th>10k</th> <th>100k</th> </tr> <tr> <td>≦ 33</td> <td>0.40</td> <td>0.55</td> <td>0.65</td> <td>0.80</td> <td>0.90</td> <td>1.00</td> </tr> <tr> <td>39 ~ 330</td> <td>0.60</td> <td>0.70</td> <td>0.80</td> <td>0.90</td> <td>0.95</td> <td>1.00</td> </tr> <tr> <td>390 ~ 1,000</td> <td>0.65</td> <td>0.80</td> <td>0.85</td> <td>0.98</td> <td>1.00</td> <td>1.00</td> </tr> <tr> <td>1,200 ≦</td> <td>0.80</td> <td>0.90</td> <td>0.95</td> <td>0.98</td> <td>1.00</td> <td>1.00</td> </tr> </table>	频率(Hz)	静电容量(μF/微法拉)							60 (50)	120	500	1k	10k	100k	≦ 33	0.40	0.55	0.65	0.80	0.90	1.00	39 ~ 330	0.60	0.70	0.80	0.90	0.95	1.00	390 ~ 1,000	0.65	0.80	0.85	0.98	1.00	1.00	1,200 ≦	0.80	0.90	0.95	0.98	1.00	1.00
频率(Hz)	静电容量(μF/微法拉)																																										
	60 (50)	120	500	1k	10k	100k																																					
≦ 33	0.40	0.55	0.65	0.80	0.90	1.00																																					
39 ~ 330	0.60	0.70	0.80	0.90	0.95	1.00																																					
390 ~ 1,000	0.65	0.80	0.85	0.98	1.00	1.00																																					
1,200 ≦	0.80	0.90	0.95	0.98	1.00	1.00																																					

寸法图

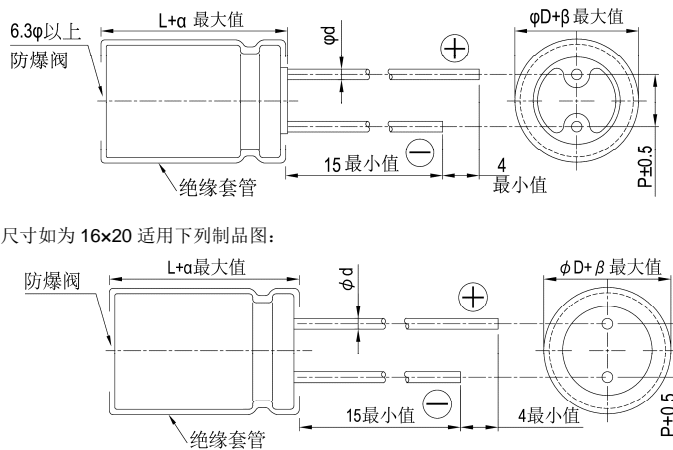

制品各项寸法 单位: 毫米

φD	5	6.3	8	10	12.5	16	18
P	2.0	2.5	3.5	5.0	5.0	7.5	7.5
φd	0.5		0.6			0.8	
α	L < 20: 1.5, L ≧ 20: 2.0						
β	0.5						

制品尺寸如为 16x20 适用下列制品图:

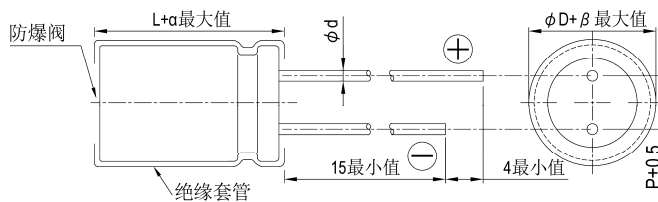



尺寸: 直径(ϕD) \times 长度(L), (毫米/mm)
 容许纹波电流: 毫安/均方根值(mA/rms), 100k 赫兹(Hz), 105 $^{\circ}$ C
 阻抗值: 欧姆(Ω)/最大值, 100k 赫兹(Hz), 20 $^{\circ}$ C

制品尺寸与容许纹波电流一览表

额定电压 V_{oc} 内容 静电容量 (μF /法拉)	6.3V (0J)					10V (1A)					16V (1C)				
	$\phi D \times L$	阻抗值		纹波电流		$\phi D \times L$	阻抗值		纹波电流		$\phi D \times L$	阻抗值		纹波电流	
		20 $^{\circ}$ C	-10 $^{\circ}$ C	120 Hz	100k Hz		20 $^{\circ}$ C	-10 $^{\circ}$ C	120 Hz	100k Hz		20 $^{\circ}$ C	-10 $^{\circ}$ C	120 Hz	100k Hz
56											5x11	0.72	1.8	116	165
68											5x11	0.72	1.8	126	180
82						5x11	0.72	1.8	116	165					
100						5x11	0.72	1.8	126	180					
120	5x11	0.72	1.8	116	165						6.3x11	0.38	0.95	179	255
180						6.3x11	0.38	0.95	179	255	6.3x15	0.27	0.68	231	330
220	6.3x11	0.38	0.95	179	255	6.3x11	0.38	0.95	196	280					
270	6.3x11	0.38	0.95	196	280	6.3x15	0.27	0.68	231	330	8x11.5 10x12.5	0.20 0.12	0.50 0.30	291 438	415 625
330	6.3x15	0.27	0.68	231	330	8x11.5	0.20	0.50	291	415	8x11.5 8x15 10x12.5	0.20 0.16 0.12	0.50 0.40 0.30	315 347 540	450 495 675
390	8x11.5	0.20	0.50	332	415	8x11.5 10x12.5	0.20 0.12	0.50 0.30	360 500	450 625					
470	8x11.5 10x12.5	0.20 0.12	0.50 0.30	360 500	450 625	8x15 10x12.5	0.16 0.12	0.40 0.30	396 540	495 675	8x15 8x20 10x16	0.16 0.11 0.084	0.40 0.28 0.21	472 512 660	590 640 825
560	8x15 10x12.5	0.16 0.12	0.40 0.30	396 540	495 675	8x15	0.16	0.40	472	590	8x20 10x16	0.11 0.084	0.28 0.21	560 728	700 910
680	10x16	0.084	0.21	660	825	8x20 10x16	0.11 0.084	0.28 0.21	512 660	640 825	10x20	0.062	0.16	832	1,040
820	8x15 8x20 10x16	0.16 0.11 0.084	0.40 0.28 0.21	472 512 728	590 640 910	8x20 10x16	0.11 0.084	0.28 0.21	560 728	700 910	10x20 10x25	0.062 0.052	0.16 0.13	904 1,008	1,130 1,260
1,000	8x20	0.11	0.28	560	700	10x20	0.062	0.16	832	1,040	10x25	0.052	0.13	1,112	1,390
1,200	10x20	0.062	0.16	936	1,040	10x20 10x25	0.062 0.052	0.16 0.13	1,017 1,134	1,130 1,260	10x30 12.5x20	0.044 0.046	0.11 0.12	1,296 1,206	1,440 1,340
1,500	10x20 10x25	0.062 0.052	0.16 0.13	1,017 1,134	1,130 1,260	10x25 10x30	0.052 0.044	0.13 0.11	1,251 1,296	1,390 1,440	10x30 12.5x20 12.5x25	0.044 0.046 0.034	0.11 0.12 0.085	1,413 1,305 1,521	1,570 1,450 1,690
1,800	10x25	0.052	0.13	1,251	1,390	10x30 12.5x20	0.044 0.046	0.11 0.12	1,413 1,206	1,570 1,340	12.5x25	0.034	0.085	1,629	1,810
2,200	10x30 12.5x20	0.044 0.046	0.11 0.12	1,296 1,206	1,440 1,340	12.5x20 12.5x25	0.046 0.034	0.12 0.085	1,305 1,521	1,450 1,690	12.5x30 16x20	0.030 0.035	0.075 0.087	1,755 1,485	1,950 1,650
2,700	10x30 12.5x20 12.5x25	0.044 0.046 0.034	0.11 0.12 0.085	1,413 1,305 1,521	1,570 1,450 1,690	12.5x25 12.5x30	0.034 0.030	0.085 0.075	1,629 1,755	1,810 1,950	12.5x30 12.5x35 16x25	0.030 0.027 0.028	0.075 0.068 0.070	1,917 1,980 1,863	2,130 2,200 2,070
3,300	12.5x25	0.034	0.085	1,629	1,810	12.5x30 12.5x35	0.030 0.027	0.075 0.068	1,917 1,980	2,130 2,200	12.5x35 12.5x40 16x25	0.027 0.024 0.028	0.068 0.060 0.070	2,196 2,151 1,880	2,390 2,440 2,070
3,900	12.5x30	0.030	0.075	1,755	1,950	12.5x35 12.5x40 16x20 16x25	0.027 0.024 0.035 0.028	0.068 0.060 0.087 0.070	2,196 2,151 1,692 1,863	2,390 2,440 1,880 2,070	16x31.5	0.025	0.063	2,115	2,350
4,700	12.5x30 12.5x35 16x20	0.030 0.027 0.035	0.075 0.068 0.087	1,917 1,980 1,44	2,130 2,200 1,600	12.5x40 16x25	0.024 0.028	0.060 0.070	2,358 2,025	2,620 2,250	16x31.5 16x35.5	0.025 0.022	0.055 0.055	2,295 2,295	2,550 2,550
5,600	12.5x35 12.5x40 16x25	0.027 0.024 0.028	0.068 0.060 0.070	2,151 2,196 1,863	2,390 2,440 2,070	16x31.5	0.025	0.063	2,115	2,350	16x35.5 16x40	0.022 0.018	0.055 0.045	2,394 2,610	2,660 2,900
6,800	12.5x40 16x25 16x31.5	0.024 0.028 0.025	0.060 0.070 0.063	2,358 2,025 2,115	2,620 2,250 2,350	16x31.5 16x35.5	0.025 0.022	0.063 0.055	2,295 2,295	2,550 2,550	16x40 18x35.5	0.018 0.021	0.045 0.053	2,844 2,448	3,160 2,720
8,200	16x31.5	0.025	0.063	2,295	2,550	16x35.5	0.022	0.055	2,448	2,720	18x35.5	0.021	0.053	2,601	2,890
10,000	16x35.5	0.022	0.055	2,691	2,990										

引线型



尺寸: 直径(ϕD) \times 长度(L), (毫米/mm)
 容许纹波电流: 毫安/均方根值(mA/rms), 100k 赫兹(Hz), 105 $^{\circ}$ C
 阻抗值: 欧姆(Ω)/最大值, 100k 赫兹(Hz), 20 $^{\circ}$ C

制品尺寸与容许纹波电流一览表

额定电压 V_{oc} 内容 静电容量 (μF /微法拉)	25V (1E)					35V (1V)					50V (1H)				
	$\phi D \times L$	阻抗值		纹波电流		$\phi D \times L$	阻抗值		纹波电流		$\phi D \times L$	阻抗值		纹波电流	
		20 $^{\circ}$ C	-10 $^{\circ}$ C	120 Hz	100k Hz		20 $^{\circ}$ C	-10 $^{\circ}$ C	120 Hz	100k Hz		20 $^{\circ}$ C	-10 $^{\circ}$ C	120 Hz	100k Hz
18											5x11	1.1	3.3	72	130
22											5x11	1.1	3.3	83	150
27						5x11	0.72	1.8	91	165					
33						5x11	0.72	1.8	99	180					
39	5x11	0.72	1.8	116	165						6.3x11	0.56	1.6	154	220
47	5x11	0.72	1.8	126	180						6.3x11	0.56	1.6	161	230
56						6.3x11	0.38	0.95	179	255	6.3x15	0.41	1.2	217	310
68						6.3x11	0.38	0.95	196	280	8x11.5	0.29	0.84	238	340
82	6.3x11	0.38	0.95	179	255	6.3x15	0.27	0.68	231	330	8x11.5	0.29	0.84	249	355
											8x15	0.25	0.75	329	470
											10x12.5	0.16	0.40	336	480
100	6.3x11	0.38	0.95	196	280						10x12.5	0.16	0.40	371	530
120	6.3x15	0.27	0.68	231	330	8x11.5	0.20	0.50	291	415	8x15	0.25	0.75	392	560
						10x12.5	0.12	0.30	438	625	8x20	0.18	0.52	427	610
											10x16	0.12	0.30	529	755
150	8x11.5	0.20	0.50	291	415	8x11.5	0.20	0.50	315	450	10x16	0.12	0.30	588	840
						10x12.5	0.12	0.30	473	675					
180	8x11.5	0.20	0.50	315	450	8x15	0.16	0.40	347	495	8x20	0.18	0.52	525	750
	10x12.5	0.12	0.30	438	625					10x20	0.088	0.22	662	945	
220	8x15	0.16	0.40	347	495	8x15	0.16	0.40	413	590	10x20	0.088	0.22	728	1,040
	10x12.5	0.12	0.30	473	675	8x20	0.11	0.28	448	640	10x25	0.068	0.17	805	1,150
						10x16	0.084	0.21	578	825					
270						8x20	0.11	0.28	490	700	10x25	0.068	0.17	896	1,280
						10x16	0.084	0.21	637	910					
330	8x15	0.16	0.40	413	590	10x20	0.062	0.16	728	1,040	10x30	0.059	0.15	882	1,260
	8x20	0.11	0.28	448	640						12.5x20	0.059	0.15	833	1,190
	10x16	0.084	0.21	578	825										
390	8x20	0.11	0.28	560	700	10x20	0.062	0.16	904	1,130	12.5x20	0.059	0.15	952	1,190
	10x16	0.084	0.21	728	910	10x25	0.052	0.13	1,008	1,260					
470	10x20	0.062	0.16	832	1,040	10x25	0.052	0.13	1,112	1,390	10x30	0.059	0.15	1,176	1,470
											12.5x25	0.045	0.11	1,192	1,490
560	10x20	0.062	0.16	904	1,130	10x30	0.044	0.11	1,152	1,440	12.5x25	0.045	0.11	1,304	1,630
	10x25	0.052	0.13	1,008	1,260	12.5x20	0.046	0.12	1,072	1,340	12.5x30	0.039	0.098	1,376	1,720
680						10x30	0.044	0.11	1,256	1,570	12.5x30	0.039	0.098	1,520	1,800
						12.5x20	0.046	0.12	1,160	1,450	12.5x35	0.033	0.083	1,512	1,900
						12.5x25	0.034	0.085	1,352	1,690	16x20	0.048	0.120	1,248	1,560
820	10x30	0.044	0.11	1,152	1,440	12.5x25	0.034	0.085	1,448	1,810	12.5x35	0.033	0.083	1,624	2,030
	12.5x20	0.046	0.12	1,072	1,340						12.5x40	0.029	0.073	1,656	2,070
											16x25	0.033	0.083	1,504	1,880
1,000	10x30	0.044	0.11	1,256	1,570	12.5x30	0.030	0.075	1,560	1,950	12.5x40	0.029	0.073	1,800	2,250
	12.5x20	0.046	0.12	1,160	1,450	16x20	0.035	0.087	1,376	1,720	16x25	0.033	0.083	1,664	2,080
	12.5x25	0.034	0.085	1,352	1,690						16x31.5	0.029	0.073	1,720	2,150
1,200	12.5x25	0.034	0.085	1,629	1,810	12.5x30	0.030	0.075	1,917	2,130	16x31.5	0.029	0.073	2,088	2,320
						12.5x35	0.027	0.068	1,980	2,200	16x35.5	0.025	0.063	2,115	2,350
						16x25	0.028	0.070	1,863	2,070					
1,500	12.5x30	0.030	0.075	1,755	1,950	12.5x35	0.027	0.068	2,151	2,390	16x35.5	0.025	0.063	2,160	2,400
	16x20	0.035	0.087	1,539	1,710	12.5x40	0.024	0.060	2,196	2,440	16x40	0.021	0.063	2,336	2,595
						16x25	0.028	0.070	2,025	2,250					
1,800	12.5x30	0.030	0.075	1,917	2,130	12.5x40	0.024	0.060	2,358	2,620	16x40	0.021	0.063	2,466	2,740
	12.5x35	0.027	0.068	1,980	2,200	16x31.5	0.025	0.063	2,115	2,350	18x35.5	0.023	0.058	2,286	2,540
	16x25	0.028	0.070	1,863	2,070										
2,200	12.5x35	0.027	0.068	2,151	2,390	16x31.5	0.025	0.063	2,295	2,550	18x35.5	0.023	0.058	2,349	2,610
	12.5x40	0.024	0.060	2,196	2,440	16x35.5	0.022	0.055	2,295	2,550	18x40	0.020	0.050	2,385	2,650
	16x25	0.028	0.070	2,025	2,250										
2,700	16x31.5	0.025	0.063	2,115	2,350	16x35.5	0.022	0.055	2,394	2,660					
						16x40	0.018	0.045	2,610	2,900					
						18x35.5	0.021	0.053	2,448	2,720					
3,300	16x31.5	0.025	0.063	2,295	2,550	18x35.5	0.021	0.053	2,601	2,890					
	16x35.5	0.022	0.055	2,295	2,550	18x40	0.017	0.043	2,709	3,010					
3,900	16x35.5	0.022	0.055	2,394	2,660										
	16x40	0.018	0.045	2,610	2,900	18x40	0.017	0.043	2,934	3,260					
	18x35.5	0.021	0.053	2,448	2,720										
4,700	18x35.5	0.021	0.053	2,601	2,890										
	18x40	0.017	0.043	2,709	3,010										
5,600	18x40	0.017	0.043	2,934	3,260										

引线型



尺寸：直径(ϕ D) \times 长度(L)，(毫米/mm)

容许纹波电流：毫安/均方根值(mA/rms)，100k 赫兹(Hz)，105 $^{\circ}$ C

阻抗值：欧姆(Ω)/最大值，100k 赫兹(Hz)，20 $^{\circ}$ C

制品尺寸与容许纹波电流一览表

额定电压 V _{DC} 内容 静电容量 (μ F/微法拉)	63V (1J)				
	ϕ D \times L	阻抗值		纹波电流	
		20 $^{\circ}$ C	-10 $^{\circ}$ C	120 Hz	100k Hz
12	5 \times 11	1.90	4.78	55	100
27	6.3 \times 11	1.10	2.78	88	160
33	6.3 \times 11	1.10	2.75	96	175
39	6.3 \times 15	0.62	1.55	161	230
47	8 \times 11.5	0.49	1.23	193	275
56	8 \times 11.5	0.49	1.23	203	290
	10 \times 12.5	0.27	0.675	294	420
68	8 \times 15	0.34	0.850	252	360
	10 \times 12.5	0.27	0.675	354	505
	10 \times 16	0.21	0.525	366	523
82	8 \times 20	0.21	0.525	350	500
100	8 \times 15	0.34	0.850	308	440
120	10 \times 16	0.210	0.525	455	650
	10 \times 20	0.160	0.400	490	700
150	8 \times 20	0.210	0.525	476	680
	10 \times 25	0.130	0.325	546	780
180	10 \times 20	0.160	0.400	553	790
	10 \times 30	0.100	0.250	672	960
220	10 \times 25	0.130	0.325	648	925
	12.5 \times 20	0.110	0.275	609	870
270	10 \times 30	0.100	0.250	812	1,160
	12.5 \times 25	0.074	0.185	805	1,150
330	12.5 \times 20	0.110	0.275	746	1,065
390	12.5 \times 25	0.074	0.185	1,088	1,280
	12.5 \times 30	0.068	0.170	1,024	1,360
470	12.5 \times 30	0.068	0.170	1,120	1,360
	12.5 \times 35	0.063	0.158	1,112	1,400
	16 \times 20	0.059	0.148	1,080	1,350
	16 \times 25	0.055	0.138	1,184	1,480
560	12.5 \times 40	0.051	0.128	1,224	1,530
	16 \times 25	0.055	0.138	1,296	1,620
680	12.5 \times 40	0.051	0.128	1,336	1,670
	16 \times 31.5	0.046	0.115	1,376	1,720
820	12.5 \times 40	0.051	0.128	1,480	1,850
	16 \times 31.5	0.046	0.115	1,512	1,890
	16 \times 35.5	0.040	0.100	1,528	1,910
1,000	16 \times 35.5	0.040	0.100	1,576	1,970
	18 \times 35.5	0.040	0.100	1,688	2,110
1,500	18 \times 35.5	0.040	0.100	2,169	2,410

产品编码说明

RXK系列 470微法拉 \pm 20% 6.3V 长脚 8 ϕ \times 11.5L 无铅引线与PET套管

RXK **471** **M** **0J** **BK** - **0811**

系列 额定静电容量 额定静电容量容许误差值 额定电压 引线加工/包装型式 胶盖型式 制品尺寸 制品引线与套管材质

注：如需了解更详细介绍，请参阅目录第 13 页“引线型产品编码说明”。

引线型

X-ON Electronics

Largest Supplier of Electrical and Electronic Components

Click to view similar products for [Aluminum Electrolytic Capacitors - Leaded](#) category:

Click to view products by [Lelon](#) manufacturer:

Other Similar products are found below :

[LXY50VB4.7M-5X11](#) [MAL203125221E3](#) [MAL204216159E3](#) [ESMG101ETD100MF11S](#) [RBC-25V-10UF-4X7](#) [RE3-35V222MJ6#](#) [RFO-100V471MJ7P#](#) [B41041A2687M8](#) [B41041A7226M8](#) [B41044A7157M6](#) [EKRG250ELL100MD07D](#) [EKXG201EC3101ML20S](#)
[EKXG351ETD6R8MJ16S](#) [EKZM160ETD471MHB5D](#) [EPA-201ELL151MM25S](#) [NCD681K10KVY5PF](#) [NRLF103M25V35X20F](#)
[KM4700/16](#) [KME50VB100M-8X11.5](#) [RXJ222M1EBK-1625](#) [SG220M1CSA-0407](#) [ES5107M016AE1DA](#) [ESX472M16B](#) [MAL211929479E3](#)
[40D506F050DF5A](#) [TE1202E](#) [36DA273F050BB2A](#) [KME25VB100M-6.3X11](#) [511D336M250EK5D](#) [511D337M035CG4D](#)
[515D477M035CG8PE3](#) [052687X](#) [EKMA500ELL4R7ME07D](#) [EKRG100ETC221MF09D](#) [NRE-S560M16V6.3X7TBSTF](#)
[ERZA630VHN182UP54N](#) [MAL214099813E3](#) [MAL211990518E3](#) [MAL204281229E3](#) [NEV680M35EF](#) [686KXM050M](#) [ERS1VM222L30OT](#)
[EGW2GM150W16OT](#) [EGS2GM6R8G12OC](#) [EHS2GM220W20OT](#) [ERF1VM222L30OT](#) [ERF1KM151G20OT](#) [EKZE500ELL101MHB5D](#)
[EKMM251VSN221MP25S](#) [RGA221M1HBK-1016G](#)