

Current Transducer HAS 50 ... 600-P

For the electronic measurement of currents: DC, AC, pulsed..., with galvanic separation between the primary circuit and the secondary circuit.

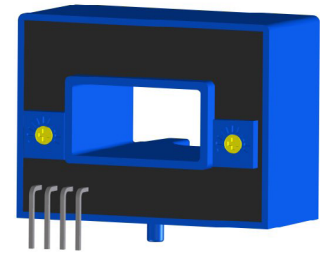

$$I_{PN} = 50 \dots 600 \text{ A}$$



Electrical data

| Type | Primary nominal rms current I_{PN} (A) | Primary current, measuring range I_{PM} (A) | RoHS since date code |
|-----------|--|---|----------------------|
| HAS 50-P | 50 | ±150 | 46065 |
| HAS 100-P | 100 | ±300 | 46062 |
| HAS 200-P | 200 | ±600 | 76273 |
| HAS 300-P | 300 | ±900 | 76273 |
| HAS 400-P | 400 | ±900 | 46131 |
| HAS 500-P | 500 | ±900 | 46216 |
| HAS 600-P | 600 | ±900 | 76273 |

| | | | |
|-----------|--|--------|----|
| U_C | Supply voltage (±5 %) ¹⁾ | ±15 | V |
| I_C | Current consumption | ±15 | mA |
| R_{INS} | Insulation resistance @ 500 V DC | > 1000 | MΩ |
| V_{out} | Output voltage (Analog) @ $\pm I_{PN}$, $R_L = 10 \text{ k}\Omega$, $T_A = 25^\circ\text{C}$ | ±4 | V |
| R_{out} | Output internal resistance approx | 100 | Ω |
| R_L | Load resistance ²⁾ | > 1 | kΩ |

Accuracy - Dynamic performance data

| | | | |
|--------------|--|---|---------------|
| X | Accuracy @ I_{PN} , $T_A = 25^\circ\text{C}$ (excluding offset) | < ±1 | % of I_{PN} |
| ϵ_L | Linearity error ³⁾ (0 ... ± I_{PN}) | < ±1 | % of I_{PN} |
| V_{OE} | Electrical offset voltage, $T_A = 25^\circ\text{C}$ | < ±20 | mV |
| V_{OH} | Hysteresis offset voltage @ $I_p = 0$, after an excursion of $1 \times I_{PN}$ | < ±20 | mV |
| TCV_{OE} | Temperature coefficient of V_{OE} | HAS 50-P < ±2 HAS 100 ... 600-P < ±1 | mV/K |
| TCV_{out} | Temperature coefficient of V_{out} (% of reading) | < ±0.1 | %/K |
| t_r | Step response time to 90 % of I_{PN} ⁴⁾ | < 3 | μs |
| BW | Frequency bandwidth ⁵⁾ (small signal, -3 dB) | DC ... 50 | kHz |

General data

| | | | |
|-------|-------------------------------|-------------------------------|----|
| T_A | Ambient operating temperature | -10 ... +80 | °C |
| T_S | Ambient storage temperature | -25 ... +85 | °C |
| m | Mass | 80 | g |
| | Standards | EN 50178:1997 UL 508: 2010 | |

- Notes:**
- ¹⁾ Operating at $\pm 12 \text{ V} \leq U_C < \pm 15 \text{ V}$ will reduce the measuring range
 - ²⁾ If the customer uses 1 kΩ of the load resistor, the primary current has to be limited as the nominal. To measure the full defined measuring range, the load resistor should be at minimum 10 kΩ
 - ³⁾ Linearity data exclude the electrical offset
 - ⁴⁾ For a $di/dt = 50 \text{ A}/\mu\text{s}$
 - ⁵⁾ Please refer to derating curves in the technical file to avoid excessive core heating at high frequency.

Features

- Hall effect measuring principle
- Insulating plastic case made of polycarbonate PBT recognized according to UL 94-V0

Advantages

- Easy mounting
- Low power consumption
- Small size and space saving
- Only one design for wide current ratings range
- High immunity to external interference.

Applications

- AC variable speed drives
- Static converters for DC motor drives
- Battery supplied applications
- Uninterruptible Power Supplies (UPS)
- Switched Mode Power Supplies (SMPS)
- Power supplies for welding applications.

Application domain

- Industrial.

Current Transducer HAS 50 ... 600-P

Insulation coordination

| | | | |
|-------------|---|-------|----|
| U_d | RMS voltage for AC insulation test, 50 Hz/1 min | 3.6 | kV |
| \hat{U}_w | Impulse withstand voltage 1.2/50 μ s | > 6.6 | kV |
| | | Min | |
| d_{cp} | Creepage distance | 7 | mm |
| d_{cl} | Clearance | 4.6 | mm |
| CTI | Comparative tracking index (group IIIa) | 275 | |

Applications examples

According to EN 50178 and IEC 61010-1 standards and following conditions:

- Over voltage category OV 3
- Pollution degree PD2
- Non-uniform field

| | EN 50178 | IEC 61010-1 |
|-----------------------------|--------------------------|-----------------|
| $d_{cp}, d_{cl}, \hat{U}_w$ | Rated insulation voltage | Nominal voltage |
| Basic insulation | 300 V | 300 V |
| Reinforced insulation | 150 V | 150 V |

Safety

This transducer must be used in limited-energy secondary circuits according to IEC 61010-1.



This transducer must be used in electric/electronic equipment with respect to applicable standards and safety requirements in accordance with the manufacturer's operating instructions.



Caution, risk of electrical shock

When operating the transducer, certain parts of the module can carry hazardous voltage (eg. primary busbar, power supply).

Ignoring this warning can lead to injury and/or cause serious damage.

This transducer is a build-in device, whose conducting parts must be inaccessible after installation.

A protective housing or additional shield could be used.

Main supply must be able to be disconnected.

Dimensions HAS 50 ... 600-P (in mm)

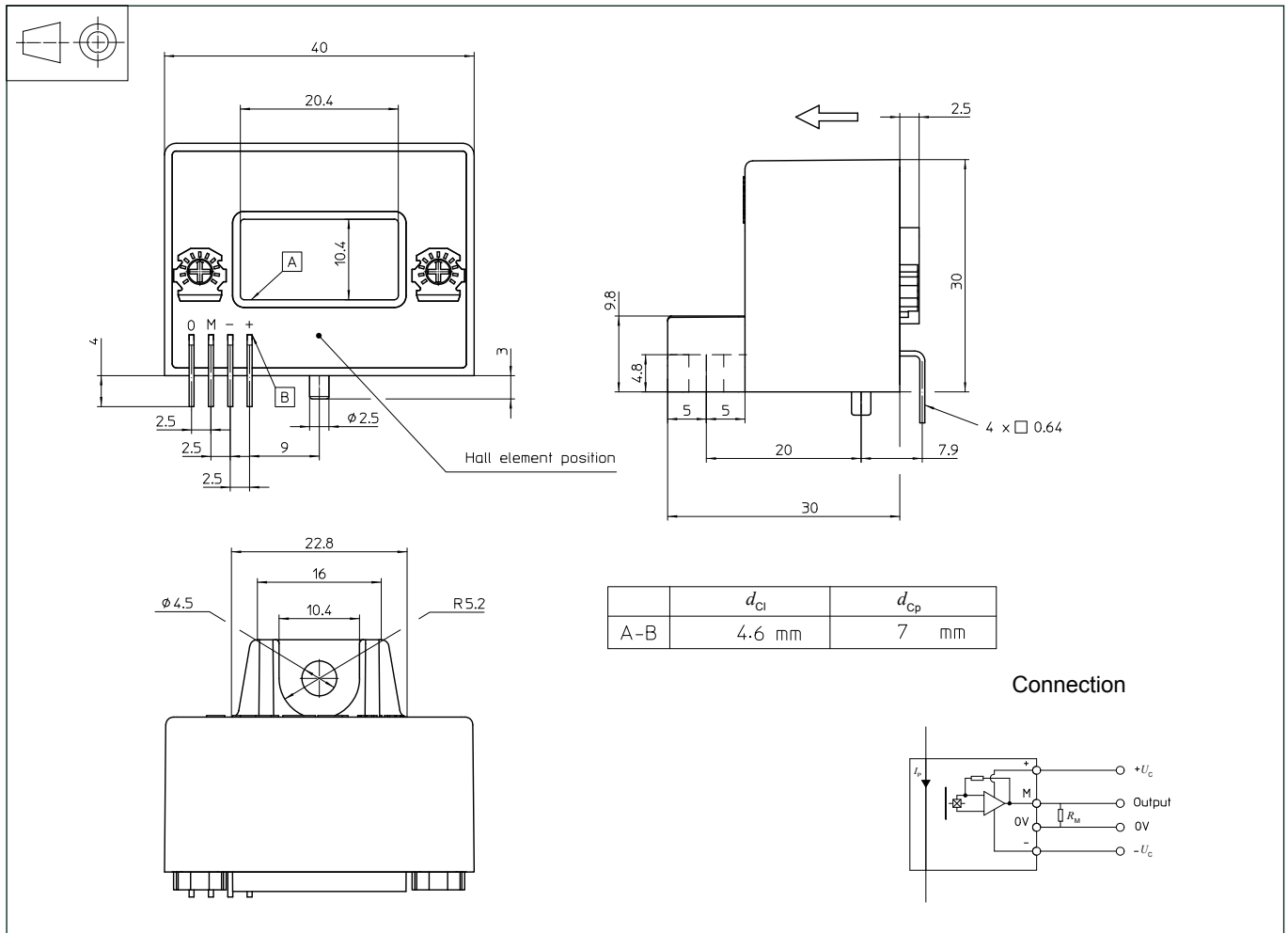

Mechanical characteristics

- General tolerance ± 0.5 mm
- Transducer fastening
 - 1 hole $\phi 4.5$ mm
 - 1 M4 steel screw
- Recommended fastening torque 0.75 N·m (± 10 %)
- Connection of secondary JST MB4P-90H

Remarks

- V_{out} is positive when I_p flows in the direction of the arrow.
- Temperature of the primary conductor should not exceed 100 °C.
- Installation of the transducer must be done unless otherwise specified on the datasheet, according to LEM Transducer Generic Mounting Rules. Please refer to LEM document N°ANE120504 available on our Web site: [Products/Product Documentation](#).
- Dynamic performances (di/dt and response time) are best with a single bar completely filling the primary hole.
- This is a standard model. For different versions (supply voltages, turns ratios, unidirectional measurements...), please contact us.

X-ON Electronics

Largest Supplier of Electrical and Electronic Components

Click to view similar products for [Board Mount Current Sensors](#) category:

Click to view products by [Lem](#) manufacturer:

Other Similar products are found below :

[CSDD1FR](#) [CSNP661-007](#) [S23P50100D15](#) [CSNE151-003](#) [ACS722LLCTR-05AB-T](#) [ACS733KLATR-40AB-T](#) [ACS71240LLCBTR-045B5](#)
[MT9523CT-20BF5](#) [TLI4971A120T5E0001XUMA1](#) [ACS724LLCTR-30AB-T](#) [ACS724LLCTR-05AB-T](#) [ACS724LLCTR-20AB-T](#)
[ACS724LLCTR-10AB-T](#) [MT9523CT-50BF5](#) [CH704100CT](#) [CC6921SO-20A](#) [CC6921BSO-20A](#) [TMCS1101A2UQDRQ1](#) [CI5930-20A](#)
[ACS733KLATR-20AB-T](#) [ACS758ECB-200B-PFF-T](#) [CI5931-30A](#) [MT9522WT-100BF5](#) [ACS758LCB-050B-PFF-T](#) [TMCS1101A4BQDRQ1](#)
[ACS758LCB-100B-PFF-T](#) [JSM6900SO-10A](#) [MT9522WT-65BF5](#) [ACS773LCB-100B-PFF-T](#) [TMCS1108A3UQDR](#) [TMCS1107A1BQDRQ1](#)
[CH70110AB5PR](#) [ACS758KCB-150B-PFF-T](#) [HACS712ELCTR-20A-T](#) [HACS712ELCTR-05B-T](#) [KTD1100-QNX](#) [LA25-NP/SP14](#) [LT308-S7](#)
[hat500-s](#) [HAT1200-S](#) [ACS712ELCTR-30A-T\(XBLW\)](#) [ACS712ELCTR-05B-T\(XBLW\)](#) [ACS712ELCTR-20A-T\(XBLW\)](#) [CT-05](#) [CT-07-100](#)
[CT-07-50](#) [L18P020S05](#) [MR-1](#) [T60404-N4646-X400](#) [T60404-N4646-X661](#)