

## Current Transducer HTFS 200..800-P

For the electronic measurement of currents : DC, AC, pulsed, mixed, with galvanic isolation between the primary circuit (high power) and the secondary circuit (electronic circuit).



All Data are given with a  $R_L = 10\text{ k}\Omega$

$I_{PN} = 200-400-600-800\text{ A}$



### Electrical data

Primary nominal current rms	Primary current measuring range	Type
$I_{PN}$ (A)	$I_{PM}$ (A)	
200	$\pm 300$	<b>HTFS 200-P</b>
400	$\pm 600$	<b>HTFS 400-P</b>
600	$\pm 900$	<b>HTFS 600-P</b>
800	$\pm 1200$	<b>HTFS 800-P</b>
$V_{OUT}$	Output voltage (Analog) @ $I_P$ $I_P = 0$	$V_{REF} \pm (1.25 \cdot I_P / I_{PN}) V$ $V_{REF} \pm 0.025 V$
$V_{REF}$	Reference voltage <sup>1)</sup> - Output voltage	$1/2 V_C \pm 0.025 V$
	$V_{REF}$ Output impedance	typ. 200 $\Omega$
	$V_{REF}$ Load impedance	$\geq 200\text{ k}\Omega$
$R_L$	Load resistance	$\geq 2\text{ k}\Omega$
$R_{OUT}$	Output internal resistance	$< 10\ \Omega$
$C_L$	Capacitive loading	$< 1\ \mu F$
$V_C$	Supply voltage ( $\pm 5\%$ )	5 V
$I_C$	Current consumption @ $V_C = 5\text{ V}$	22 mA

### Accuracy - Dynamic performance data

<b>X</b>	Accuracy <sup>2)</sup> @ $I_{PN}$ , $T_A = 25^\circ C$	$\leq \pm 1$	% of $I_{PN}$
$\epsilon_L$	Linearity error ( $0 \dots 1.5 \times I_{PN}$ )	$\leq \pm 0.5$	% of $I_{PN}$
<b>TCV<sub>OE</sub></b>	Temperature coefficient of $V_{OE}$ @ $I_P = 0$	$\leq \pm 0.3$	mV/K
<b>TCV<sub>REF</sub></b>	Temperature coefficient of $V_{REF}$	$\leq \pm 0.01$	%/K
$rcv_{OUT}/V_{REF}$	Temperature coefficient of $V_{OUT} / V_{REF}$ @ $I_P = 0$	$\leq \pm 0.2$	mV/K
<b>TCV<sub>OUT</sub></b>	Temperature coefficient of $V_{OUT}$	$\leq \pm 0.05\%$	of reading/K
$V_{OM}$	Magnetic offset voltage @ $I_P = 0$ , after an overload of $3 \times I_{PN DC}$	$< \pm 0.5$	% of $I_{PN}$
$t_{ra}$	Reaction time @ 10 % of $I_{PN}$	$< 3$	$\mu s$
$t_r$	Response time to 90 % of $I_{PN}$ step	$< 7$	$\mu s$
<b>di/dt</b>	di/dt accurately followed	$> 100$	A/ $\mu s$
$V_{no}$	Output voltage noise (DC .. 10 kHz)	$< 15$	mVpp
	(DC .. 1 MHz)	$< 40$	mVpp
<b>BW</b>	Frequency bandwidth (-3 dB) <sup>3)</sup>	DC .. 50	kHz

### General data

$T_A$	Ambient operating temperature	- 40 .. + 105	$^\circ C$
$T_S$	Ambient storage temperature	- 40 .. + 105	$^\circ C$
$m$	Mass	60	g
	Standard	EN 50178: 1997	

**Notes :** <sup>1)</sup> It is possible to overdrive  $V_{REF}$  with an external reference voltage between 2 - 2.8 V providing its ability to sink or source approx. 2.5 mA.

<sup>2)</sup> Excluding offset and Magnetic offset voltage.

<sup>3)</sup> Small signal only to avoid excessive heatings of the magnetic core.

### Features

- Hall effect measuring principle
- Galvanic isolation between primary and secondary circuit
- Low power consumption
- Single power supply +5V
- Ratiometric offset
- $T_A = -40..+105\ ^\circ C$
- Fixation by M3 nuts and screws
- Isolated plastic case recognized according to UL 94-V0.

### Advantages

- Small size and space saving
- Only one design for wide current ratings range
- High immunity to external interference.
- $V_{REF}$  IN/OUT.

### Applications

- Forklift drives
- AC variable speed drives
- Static converters for DC motor drives
- Battery supplied applications
- Uninterruptible Power Supplies (UPS)
- Switched Mode Power Supplies (SMPS)
- Power supplies for welding applications.

### Application domain

- Industrial.

## Current Transducer HTFS 200..800-P

### Isolation characteristics

- V<sub>b</sub>** Rated isolation voltage rms with following conditions
- Over voltage category III
  - Pollution degree 2
  - Non-uniform field

	EN501 78	IEC61 010-1
Single insulation	300V	300V
Reinforced insulation	150V	150V

<b>V<sub>d</sub></b>	Rms voltage for AC isolation test, 50 Hz, 1 min	2.5	kV
<b>V<sub>e</sub></b>	Partial discharge extinction voltage rms @ 10pC	> 1	kV
<b>V<sub>w</sub></b>	Impulse withstand voltage 1.2/50 μs	4	kV
<b>dCp</b>	Creepage distance	> 4	mm
<b>dCl</b>	Clearance distance	> 4	mm
<b>CTI</b>	Comparative tracking index (Group IIIa)	> 220	

If insulated cable is used for the primary circuit, the voltage category could be improved with the following table :

Cable insulation (primary)	Category
HAR 03	300V CAT III
HAR 05	400V CAT III
HAR 07	500V CAT III

### Safety



This transducer must be used in electric/electronic equipment with respect to applicable standards and safety requirements in accordance with the manufacturer's operating instructions.



Caution! Risk of electrical shock

When operating the transducer, certain parts of the module can carry hazardous voltage (eg. primary busbar, power supply).

Ignoring this warning can lead to injury and/or cause serious damage.

This transducer is a built-in device, whose conducting parts must be inaccessible after installation.

A protective housing or additional shield could be used.

Main supply must be able to be disconnected.

## Dimensions HTFS 200..800-P (in mm. 1 mm = 0.0394 inch)

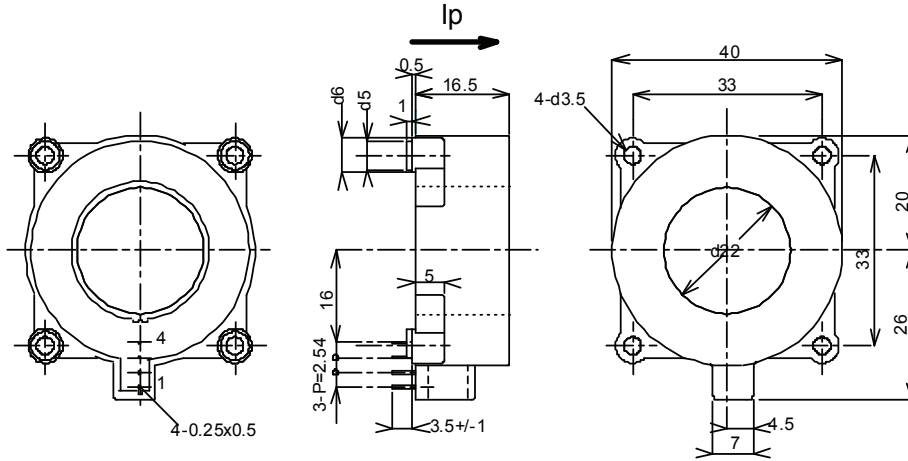

### Required Connection Circuit

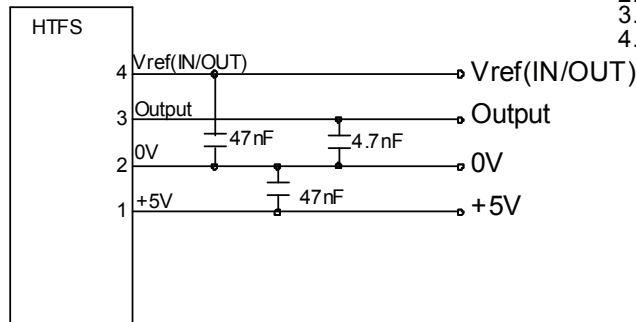

### Terminal Pin

- 1...+5V
- 2...0V
- 3...Output
- 4...Vref

### Operation Principle

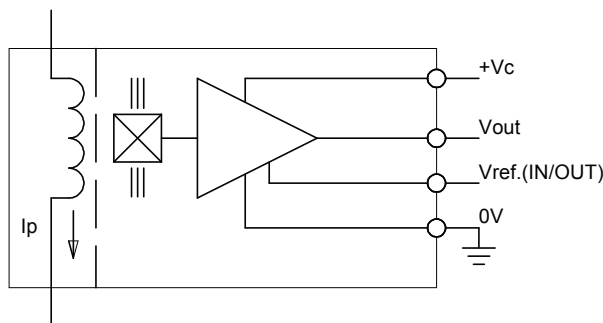

### Mechanical characteristics

- General tolerance  $\pm 0.2$  mm
- Fastening by 4 x M3 (not supplied)
- Recommended fastening torque  $< 2.5$  Nm
- Fastening & connection of secondary 4 pins 0.5 x 0.25
- Recommended PCB hole  $\varnothing 0.7$  mm

### Remarks

- $V_{OUT}$  is positive when  $I_P$  flows in the direction of the arrow.
- Temperature of the primary conductor should not exceed  $120^\circ\text{C}$ .

## X-ON Electronics

Largest Supplier of Electrical and Electronic Components

*Click to view similar products for [Interface - Specialized category](#):*

*Click to view products by [Lem manufacturer](#):*

Other Similar products are found below :

[CY7C910-51LMB](#) [MC33689DPEWR2](#) [MC33975TEKR2](#) [MEC1632-AUE](#) [MC33978AEK](#) [NVT4555UKZ](#) [TJA1081TS,112](#) [RKSAS4](#)  
[HMC677G32](#) [LPC47N207-JV](#) [FTP-637DSL633R](#) [MAX7348AEP+](#) [SM712GX04LF04-BA](#) [DS2413P+T&R](#) [NCN5193MNTWG](#)  
[MC34978AEK](#) [MC33689DPEW](#) [MC33889BPEG](#) [NCV7381DP0R2G](#) [PCA9704PWJ](#) [S6BT112A01SSBB202](#) [MAX7347AEE+](#) [DS8113-](#)  
[RNG+T&R](#) [DS8024-RJX+T&R](#) [NCN5192MNRG](#) [DS8023-RRX+T&R](#) [DS8024-RRX+T&R](#) [ST8034HCQR](#) [XP71055](#)  
[TC7PCI3212MT,LF\(S](#) [ASI4UE-F-G1-ST](#) [HOA6241-001](#) [MEC1310-NU](#) [SC74HC4066ADTR2G](#) [TDA8035HNC1S1QL](#) [TNY380PN](#)  
[RMT3PB080](#) [AS3935-BQFT](#) [0714300268](#) [MAX9924UAUB/V+](#) [MAX3120CUA+](#) [MAX3171CAI](#) [NCN8025MTTBG](#) [DS8023-RRX](#)  
[DS2406P+T&R](#) [DS8007-ENG+](#) [DS8007A-EAG+](#) [DS2482X-101T](#) [DS1886T+](#) [DG407AK/883B](#)