

## Current Transducer LA 130-P

For the electronic measurement of currents: DC, AC, pulsed..., with galvanic separation between the primary circuit and the secondary circuit.



RoHS



UL US

$$I_{PN} = 130 \text{ A}$$

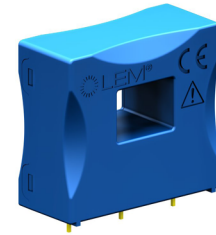

### Electrical data

$I_{PN}$	Primary nominal rms current	130	A		
$I_{PM}$	Primary current, measuring range	0 .. ±200	A		
$R_M$	Measuring resistance @ 85 °C	$R_{M \min}$	$R_{M \max}$		
		with ±12 V	@ ±130 A <sub>max</sub>	10	43
		@ ±200 A <sub>max</sub>	10	18	Ω
	with ±15 V	@ ±130 A <sub>max</sub>	30	65	Ω
	@ ±200 A <sub>max</sub>	30	32	Ω	
$I_{SN}$	Secondary nominal rms current	130	mA		
$K_N$	Conversion ratio	1 : 1000			
$U_C$	Supply voltage (±5 %)	±12 .. 15	V		
$I_C$	Current consumption	10 (@ ±15 V) + $I_s$	mA		

### Accuracy - Dynamic performance data

$X$	Accuracy @ $I_{PN}$ , $T_A = 25$ °C	<0.5	%	
$\epsilon_L$	Linearity error	<0.1	%	
$I_{OE}$	Electrical offset current @ $I_P = 0$ , $T_A = 25$ °C	Typ	Max	
			±0.20	mA
$I_{OM}$	Magnetic offset current @ $I_P = 0$ and specified $R_M$ , after an overload of $3 \times I_{PN}$		±0.50	mA
$I_{OT}$	Temperature variation of $I_O$ -40 °C .. +85 °C	±0.30	±0.60	mA
$t_{ra}$	Reaction time	<300	ns	
$t_r$	Step response time <sup>1)</sup> to 90 % of $I_{PN}$	<500	ns	
$di/dt$	$di/dt$ accurately followed	>100	A/μs	
$BW$	Frequency bandwidth (-1 dB)	DC .. 150	kHz	

### General data

$T_A$	Ambient operating temperature	-40 .. +85	°C
$T_S$	Ambient storage temperature	-40 .. +90	°C
$R_S$	Resistance of secondary winding @ $T_A = 25$ °C	21±1.5	Ω
$m$	Mass	<25	g
	Standards	EN 50178: 1997 UL 508: 2010	

### Features

- Closed loop (compensated) current transducer using the Hall effect
- Insulating plastic case recognized according to UL 94-V0.

### Advantages

- Excellent accuracy
- Very good linearity
- Low temperature drift
- Optimized response time
- Wide frequency bandwidth
- No insertion losses
- High immunity to external interference
- Current overload capability.

### Applications

- AC variable speed drives and servo motor drives
- Static converters for DC motor drives
- Battery supplied applications
- Uninterruptible Power Supplies (UPS)
- Switched Mode Power Supplies (SMPS)
- Power supplies for welding applications.

### Application domain

- Industrial.

**Note:** <sup>1)</sup> With a  $di/dt$  of 100 A/μs.

## UL 508:Ratings and assumptions of certification LA 130-P

File # E189713 Volume: 2 Section: 1

### Standards

- CSA C22.2 NO. 14 - 10 INDUSTRIAL CONTROL EQUIPMENT - Edition 11 - Revision Date 2011/08/01
- UL 508 STANDARD FOR INDUSTRIAL CONTROL EQUIPMENT - Edition 17 - Revision Date 2010/04/15.

Parameter	Symbol	Unit	Value
Primary potential involved		V AC/DC	600
Max surrounding air temperature	$T_A$	°C	85
Primary current	$I_P$	A	0 to 130
Secondary supply voltage	$U_C$	V DC	±12 .. 15
Output signal	$I_{SN}$	mA	130

### Conditions of acceptability

*When installed in the end-use equipment, consideration shall be given to the following:*

- 1 - These devices must be mounted in a suitable end-use enclosure.*
- 2 - The terminals have not been evaluated for field wiring.*
- 3 - The LA 130 series are intended to be mounted on the printed wiring board of the end-use equipment (with a minimum CTI of 100).*
- 4 - Low voltage circuits are intended to be powered by a circuit derived from an isolating source (such as a transformer, optical isolator, limiting impedance or electro-mechanical relay) and having no direct connection back to the primary circuit (other than through the grounding means).*
- 5 - Base on results of temperature tests, in the end use application, a maximum of 100 °C cannot be exceeded at soldering point between primary coil pin and soldering point of on the primary bus bar (corrected to the appropriate evaluated max. surrounding air).*

### Marking

Only those products bearing the UL or UR Mark should be considered to be Listed or Recognized and covered under UL's Follow-Up Service. Always look for the Mark on the product.

## Current Transducer LA 130-P

### Insulation coordination

$U_d$	Rms voltage for AC insulation test, 50 Hz/1 min	4.3	kV
$\hat{U}_w$	Impulse withstand voltage 1.2/50 $\mu$ s	8	kV
$U_e$	Partial discharge extinction rms voltage @ 10 pC	1.3	kV
		Min	
$d_{cp}$	Creepage distance	8	mm
$d_{cl}$	Clearance	8	mm
$CTI$	Comparative tracking index (group I)	600	

### Applications examples

According to EN 50178 and IEC 61010-1 standards and following conditions:

- Over voltage category OV 3
- Pollution degree PD2
- Non-uniform field

	EN 50178	IEC 61010-1
$d_{cp}, d_{cl}, \hat{U}_w$	Rated insulation voltage	Nominal voltage
Basic insulation	1000 V	1000 V
Reinforced insulation	600 V	400 V

### Safety

This transducer must be used in limited-energy secondary circuits according to IEC 61010-1.



This transducer must be used in electric/electronic equipment with respect to applicable standards and safety requirements in accordance with the manufacturer's operating instructions.



Caution, risk of electrical shock

When operating the transducer, certain parts of the module can carry hazardous voltage (eg. primary busbar, power supply).

Ignoring this warning can lead to injury and/or cause serious damage.

This transducer is a build-in device, whose conducting parts must be inaccessible after installation.

A protective housing or additional shield could be used.

Main supply must be able to be disconnected.

## Dimensions LA 130-P (in mm)

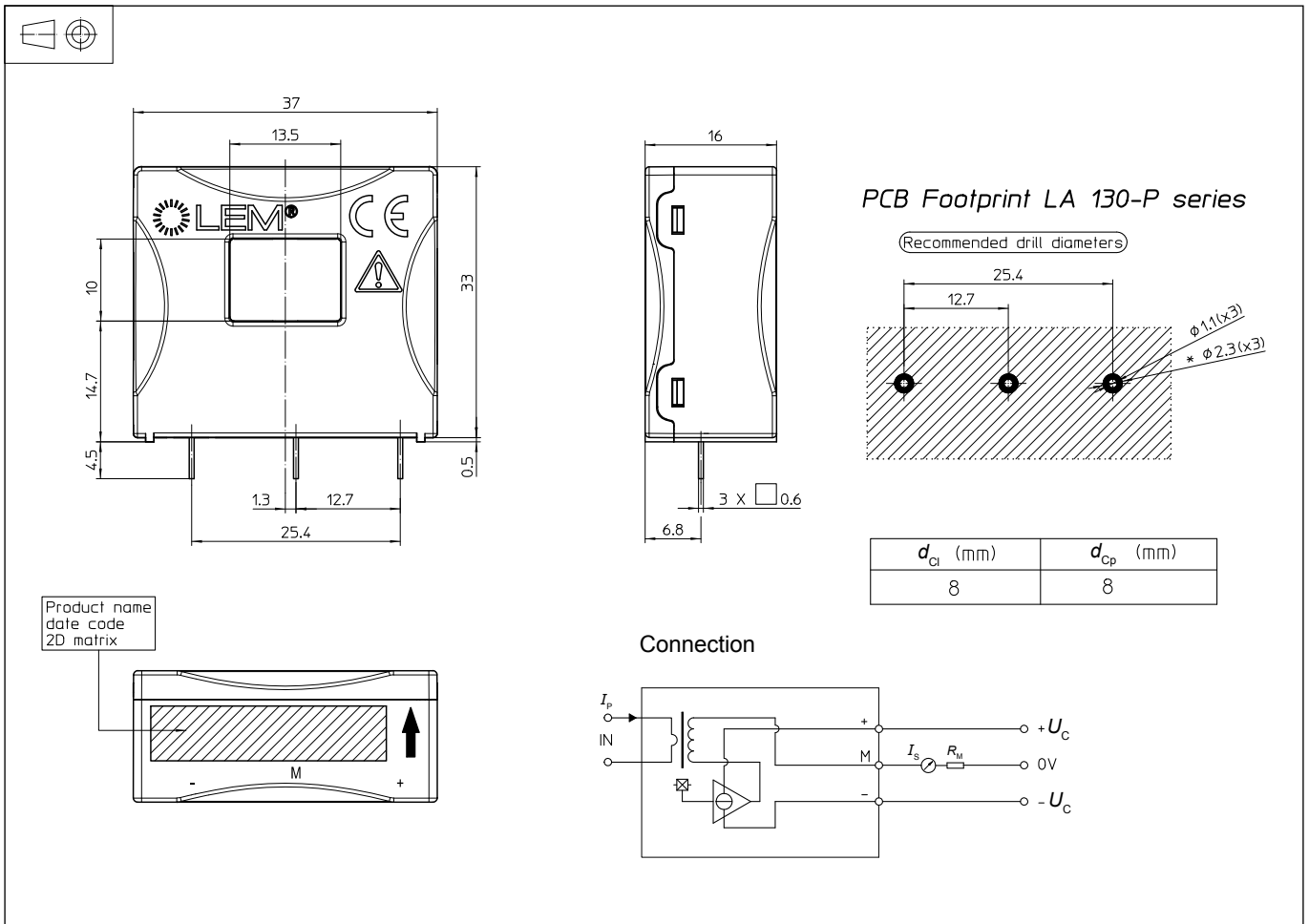

## Mechanical characteristics

- General tolerance  $\pm 0.5$  mm
- Primary through-hole  $13.5 \times 10$  mm
- Fastening & connection of secondary  
Recommended PCB hole  $3$  pins  $0.6 \times 0.6$  mm  
 $\phi 1.1$  mm

## Remarks

- $I_s$  is positive when  $I_p$  flows in the direction of the arrow.
- Temperature of the primary conductor should not exceed  $100^\circ\text{C}$ .
- Installation of the transducer must be done unless otherwise specified on the datasheet, according to LEM Transducer Generic Mounting Rules. Please refer to LEM document N°ANE120504 available on our Web site: [Products/Product Documentation](#).
- Dynamic performances ( $di/dt$  and response time) are best with a single bar completely filling the primary hole.
- This is a standard model. For different versions (supply voltages, turns ratios, unidirectional measurements...), please contact us.

## X-ON Electronics

Largest Supplier of Electrical and Electronic Components

*Click to view similar products for [Industrial Current Sensors](#) category:*

*Click to view products by [Lem](#) manufacturer:*

Other Similar products are found below :

[CSNS181](#) [S28S500D24ZM](#) [CSNS300M-001](#) [L05Z800S15](#) [5SHT-151-E](#) [5SHT-500-E](#) [T60404-B4658-X030](#) [T60404-B4658-X029](#) [SAO-Q1N](#) [SAO-Q2N](#) [CSNS300F-002](#) [CSCA0075A000U12J01](#) [SAO-S1N](#) [L34S1T5D15T](#) [L34S500D15T](#) [L34S1T0D15T](#) [CSNS300M-500](#) [LA200-P](#) [ACS724LLCTR-10AB-T](#) [ACS711KEXLT-15AB-T](#) [20310200202](#) [ACS770LCB-050U-PFF-T](#) [LCS10T12](#) [20320500101](#) [20310508201](#) [CCT354571-300-24-00](#) [20320300101](#) [S29S1T0D24Z](#) [CCT272440-80-10-02](#) [DCSA20](#) [S21S180D15JN](#) [L31S300S05FS](#) [T60404-N4644-X021](#) [ECSL61AH](#) [ISB-300-A-802](#) [ISB-300-A-604](#) [ISB-175-A-802](#) [ISB-175-A-800](#) [ISB-175-A-604](#) [ISB-100-A-802](#) [LPMG12](#) [ECS41BC](#) [ECS41BD](#) [SAO-S5N](#) [DCSA50](#) [ECS21BC](#) [ACS726LLFTR-20B-T](#) [A-CS010B](#) [A-CS050B](#) [A-CS100B](#)