

Current Transducer LA 25-NP/SP14

For the electronic measurement of currents: DC, AC, pulsed..., with galvanic isolation between the primary circuit and the secondary circuit.

$$I_{PN} = 0.25 \text{ A}$$



Electrical data

| | | | |
|----------|---|-------------------------------|------------------|
| I_{PN} | Primary nominal current rms | 0.25 | A |
| I_{PM} | Primary current, measuring range | 0 .. ± 0.36 | A |
| R_M | Measuring resistance with $\pm 15 \text{ V}$ | $R_{M \min}$ | $R_{M \max}$ |
| | | @ $\pm 0.25 \text{ A}_{\max}$ | 100 320 Ω |
| | @ $\pm 0.36 \text{ A}_{\max}$ | 100 190 | Ω |
| I_{SN} | Secondary nominal current rms | 25 | mA |
| K_N | Conversion ratio | 100 : 1000 | |
| V_C | Supply voltage ($\pm 5 \%$) | ± 15 | V |
| I_C | Current consumption | $10 + I_S$ | mA |

Accuracy - Dynamic performance data

| | | | |
|--------------|---|------------|------------------|
| X | Accuracy @ I_{PN} , $T_A = 25^\circ\text{C}$ | ± 0.5 | % |
| ϵ_L | Linearity error | < 0.2 | % |
| I_O | Offset current ¹⁾ @ $I_p = 0$, $T_A = 25^\circ\text{C}$ | Typ | Max |
| | | ± 0.05 | ± 0.15 |
| I_{OM} | Magnetic offset current ²⁾ @ $I_p = 0$ and specified R_M , after an overload of $3 \times I_{PN}$ | ± 0.05 | ± 0.15 |
| | | mA | mA |
| I_{OT} | Temperature variation of I_O -10°C .. +70°C | ± 0.10 | ± 0.35 |
| t_r | Response time ³⁾ to 90 % of I_{PN} step | < 1 | μs |
| di/dt | di/dt accurately followed | > 50 | A/ μs |
| BW | Frequency bandwidth (-1 dB) | DC .. 150 | kHz |

General data

| | | | |
|----------|--|----------------|------------------|
| T_A | Ambient operating temperature | -10 .. +70 | $^\circ\text{C}$ |
| T_S | Ambient storage temperature | -25 .. +85 | $^\circ\text{C}$ |
| R_P | Primary coil resistance @ $T_A = 25^\circ\text{C}$ | < 860 | m Ω |
| R_S | Secondary coil resistance @ $T_A = 70^\circ\text{C}$ | 110 | Ω |
| L_P | Insertion inductance | 496 | μH |
| R_{IS} | Isolation resistance @ 500 V, $T_A = 25^\circ\text{C}$ | > 1500 | M Ω |
| m | Mass | 22 | g |
| | Standards | EN 50178: 1997 | |

Notes: ¹⁾ Measurement carried out after 15 mn functioning
²⁾ The result of the coercive field of the magnetic circuit
³⁾ With a di/dt of 100 A/ μs .

Features

- Closed loop (compensated) current transducer using the Hall effect
- Isolated plastic case recognized according to UL 94-V0.

Special features

- $I_{PN} = 0.25 \text{ A}$
- $I_{PM} = 0 .. \pm 0.36 \text{ A}$
- $K_N = 100 : 1000$
- $T_A = -10^\circ\text{C} .. +70^\circ\text{C}$.

Advantages

- Excellent accuracy
- Very good linearity
- Low temperature drift
- Optimized response time
- Wide frequency bandwidth
- No insertion losses
- High immunity to external interference
- Current overload capability.

Applications

- AC variable speed drives and servo motor drives
- Static converters for DC motor drives
- Battery supplied applications
- Uninterruptible Power Supplies (UPS)
- Switched Mode Power Supplies (SMPS)
- Power supplies for welding applications.

Application domain

- Industrial.

Current Transducer LA 25-NP/SP14

Isolation characteristics

| | | | |
|-------------|--|------|----|
| V_d | Rms voltage for AC insulation test, 50 Hz, 1 min | 2.5 | kV |
| \hat{V}_w | Impulse withstand voltage 1.2/50 μ s | 16 | kV |
| | | Min | |
| dCp | Creepage distance | 19.5 | mm |
| dCI | Clearance | 19.5 | mm |
| CTI | Comparative Tracking Index (group IIIa) | 175 | |

Applications examples

According to EN 50178 and IEC 61010-1 standards and following conditions:

- Over voltage category OV 3
- Pollution degree PD2
- Non-uniform field

| | EN 50178 | IEC 61010-1 |
|---|--------------------------|-----------------|
| dCp, dCI, \hat{V}_w | Rated insulation voltage | Nominal voltage |
| Basic insulation | 1700 V | 1700 V |
| Reinforced insulation | 600 V | 600 V |

Safety



This transducer must be used in electric/electronic equipment with respect to applicable standards and safety requirements in accordance with the manufacturer's operating instructions.



Caution, risk of electrical shock

When operating the transducer, certain parts of the module can carry hazardous voltage (eg. primary busbar, power supply).

Ignoring this warning can lead to injury and/or cause serious damage.

This transducer is a build-in device, whose conducting parts must be inaccessible after installation.

A protective housing or additional shield could be used.

Main supply must be able to be disconnected.

Dimensions LA 25-NP/SP14 (in mm)

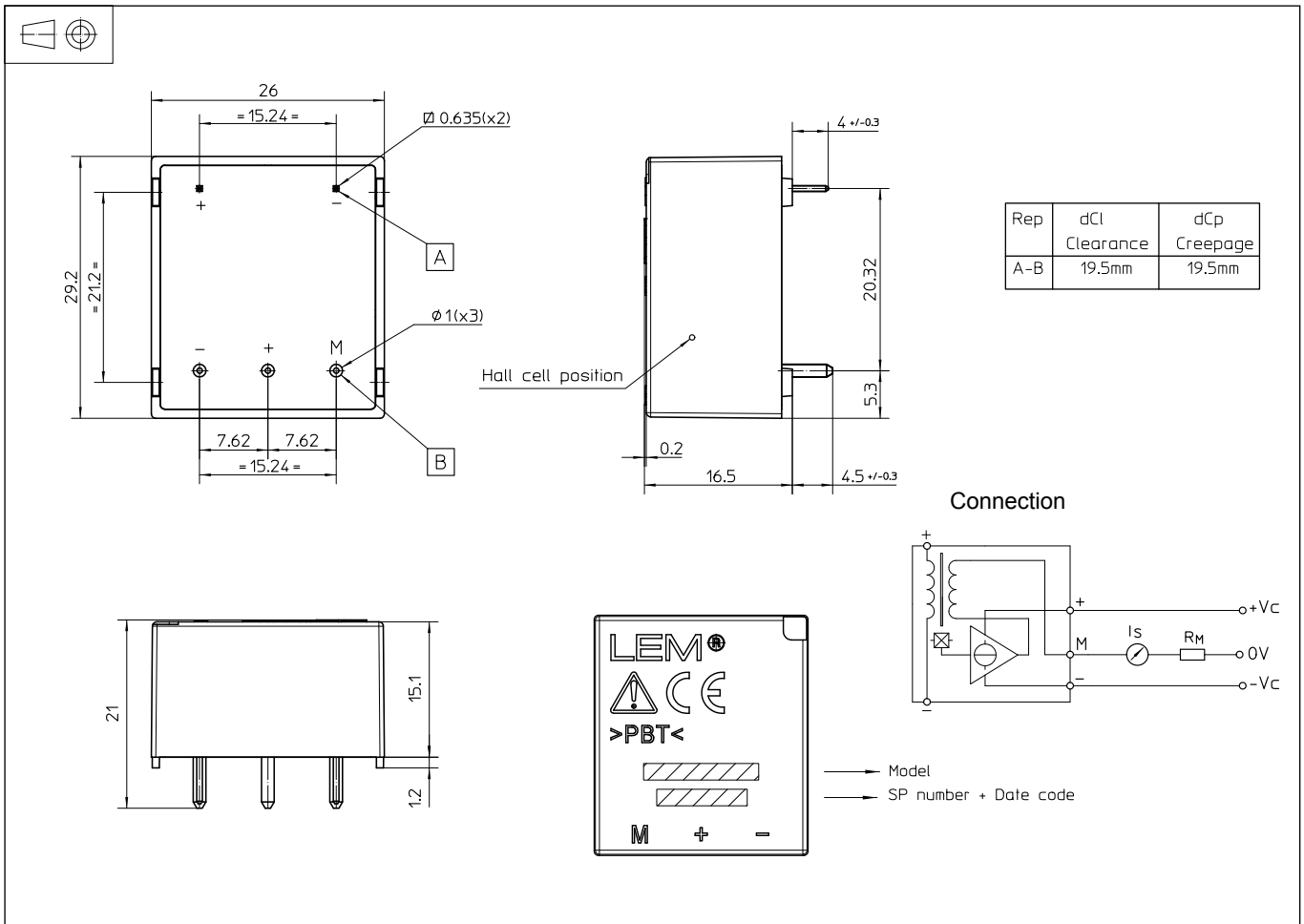

Mechanical characteristics

- General tolerance ± 0.2 mm
- Fastening & connection of primary 2 pins
0.635 x 0.635 mm
- Fastening & connection of secondary 3 pins $\varnothing 1$ mm
- Recommended PCB hole 1.2 mm

Remark

- I_s is positive when I_p flows from terminal + to terminal -.

X-ON Electronics

Largest Supplier of Electrical and Electronic Components

Click to view similar products for [Board Mount Current Sensors](#) category:

Click to view products by [Lem](#) manufacturer:

Other Similar products are found below :

[CSDD1FR](#) [CSNP661-007](#) [S23P50100D15](#) [CSNE151-003](#) [ACS722LLCTR-05AB-T](#) [ACS733KLATR-40AB-T](#) [ACS71240LLCBTR-045B5](#)
[MT9523CT-20BF5](#) [TLI4971A120T5E0001XUMA1](#) [ACS724LLCTR-30AB-T](#) [ACS724LLCTR-05AB-T](#) [ACS724LLCTR-20AB-T](#)
[ACS724LLCTR-10AB-T](#) [MT9523CT-50BF5](#) [CH704100CT](#) [CC6921SO-20A](#) [CC6921BSO-20A](#) [TMCS1101A2UQDRQ1](#) [CI5930-20A](#)
[ACS733KLATR-20AB-T](#) [ACS758ECB-200B-PFF-T](#) [CI5931-30A](#) [MT9522WT-100BF5](#) [ACS758LCB-050B-PFF-T](#) [TMCS1101A4BQDRQ1](#)
[ACS758LCB-100B-PFF-T](#) [JSM6900SO-10A](#) [MT9522WT-65BF5](#) [ACS773LCB-100B-PFF-T](#) [TMCS1107A1BQDRQ1](#)
[TLE4971A025N5E0001XUMA1](#) [CH70110AB5PR](#) [ACS758KCB-150B-PFF-T](#) [HACS712ELCTR-20A-T](#) [HACS712ELCTR-05B-T](#)
[KTD1100-QNX](#) [LA25-NP/SP14](#) [LT308-S7](#) [hat500-s](#) [HAT1200-S](#) [ACS712ELCTR-30A-T\(XBLW\)](#) [ACS712ELCTR-05B-T\(XBLW\)](#)
[ACS712ELCTR-20A-T\(XBLW\)](#) [GZC6201AC020PK05](#) [HX712-20-S](#) [HX714-05-S](#) [HX714-20-S](#) [HX714-30-S](#) [HX724-05B-S](#) [HX724-30B-S](#)