



LEOPARD IMAGING INC

# LI-AR0820-GMSL2-xxxH

## Data Sheet

### Key Features

- ON SEMI AR0820 8.3M CMOS RCCB Sensor
- Optical format: 1/2"
- Maximum resolution: 3840H x 2160V
- Pixel size: 2.1 um x 2.1 um
- Output 12 bit Raw data
- Support 12V Power
- Lens: H 60 / 110
- GMSL2 Serializer
- Connector: FAKRA Z TYPE
- Water proof: IP67
- Operation Temp: -40 ~ 85 °C
- Storage Temp: -40 ~ 125 °C
- Size: 30 x 30 x 29.2 mm
- Weight: 45 g
- Part#: **LI-AR0820-GMSL2-xxxH**



### Application

- High Performance ADAS (Automotive Driver Assistant System)
- Autonomous Driving

### Dimensions

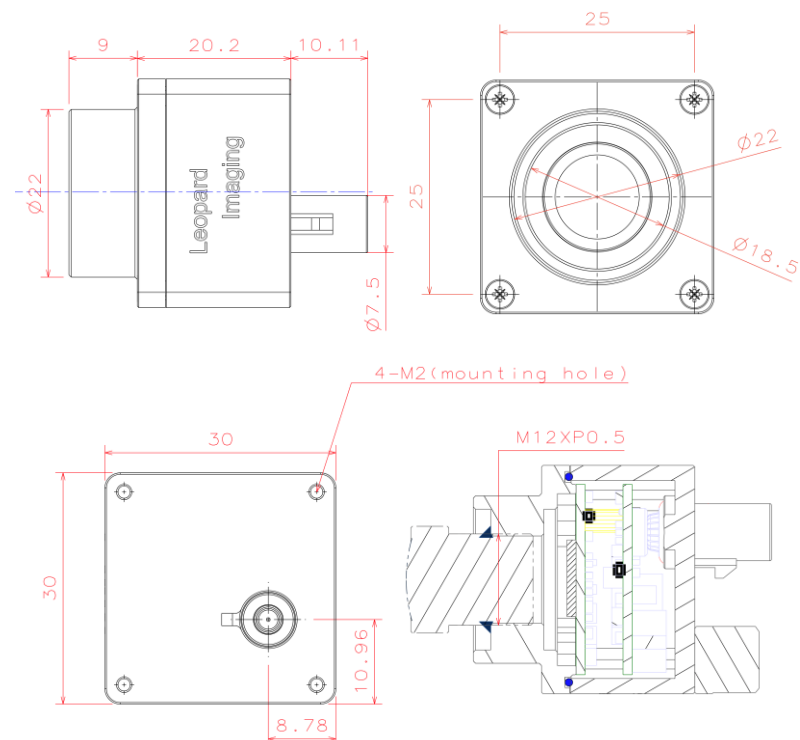

Leopard Imaging Inc.

48820 Kato Rd, Suite 100B, Fremont, CA 94538, USA  
Phone: +1-408-263-0988  
Fax: +1-408-217-1960  
Email: sales@leopardimaging.com  
Website: www.leopardimaging.com

# BOM

#	Name	SPEC	QTY/SET
1	Lens	M12 lens	1
2	Screw	M2*8 cross flat head black ZINC	4
3	Shell 2	AL6061-T6 BLACK Anodizing	1
4	Sealing ring	Silicon rubber, White	1
5	LI-AR0820-MIPI	AR0820 sensor board	1
6	Copper pillar	M2*5+3	2
7	LI-GMSL2-FKR	GMSL2 board	1
8	O ring	6.5*1.5 Silicon rubber Red	1
9	Screw	M2*4 cross pan head black ZINC	2
10	Shell 1	AL6061-T6 BLACK Anodizing	1

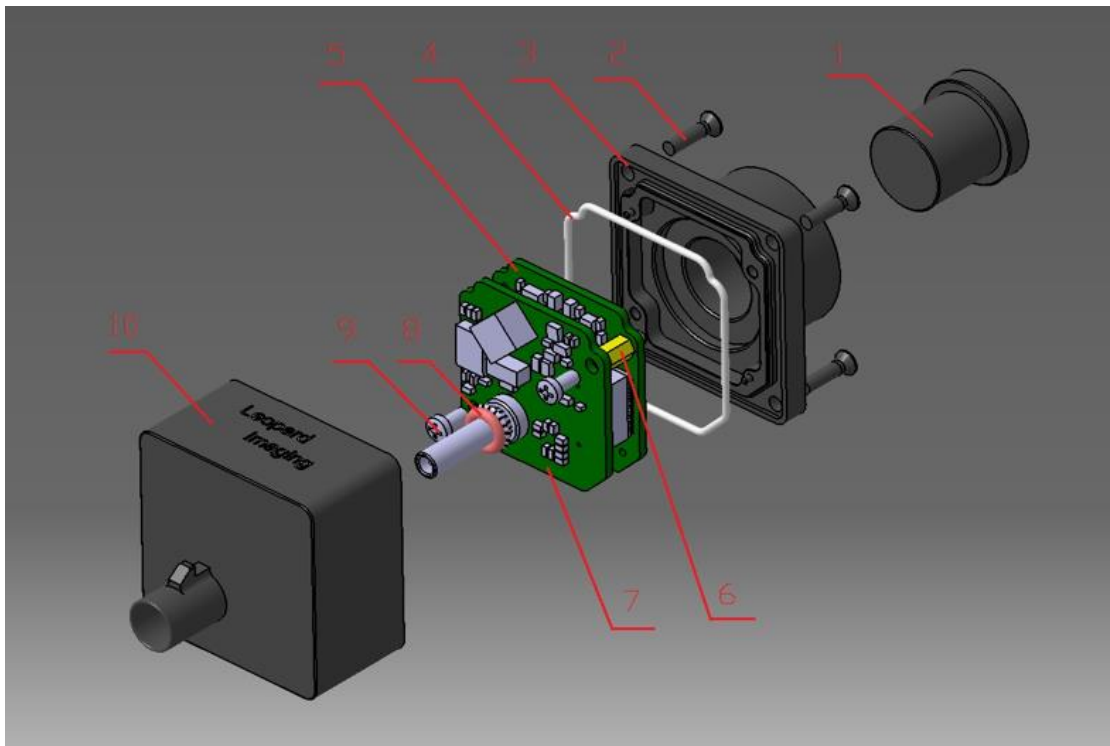

Leopard Imaging Inc.

48820 Kato Rd, Suite 100B, Fremont, CA 94538, USA  
 Phone: +1-408-263-0988  
 Fax: +1-408-217-1960  
 Email: sales@leopardimaging.com  
 Website: www.leopardimaging.com

# Camera boards Dimensions

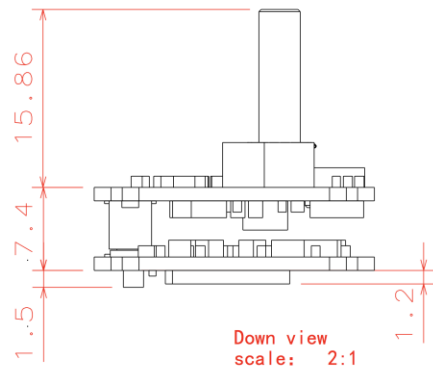
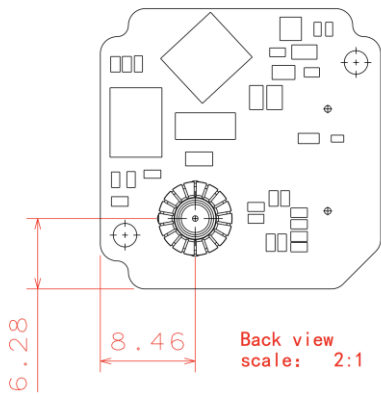
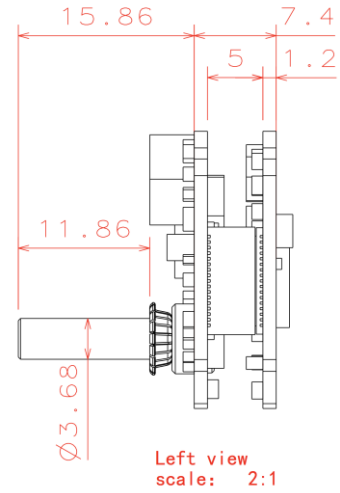
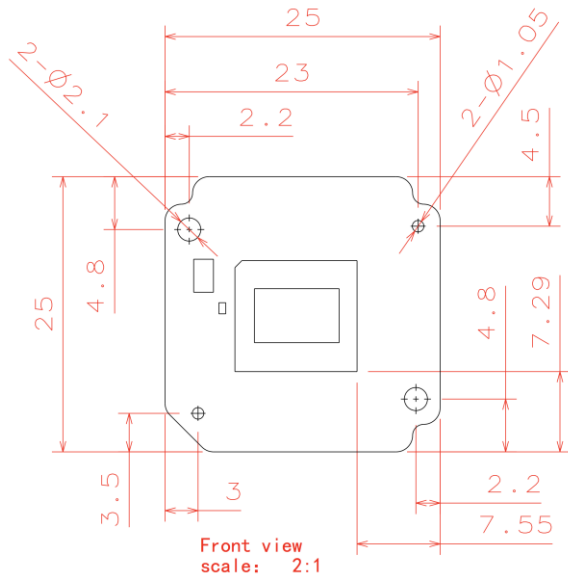

Leopard Imaging Inc.

48820 Kato Rd, Suite 100B, Fremont, CA 94538, USA  
 Phone: +1-408-263-0988  
 Fax: +1-408-217-1960  
 Email: sales@leopardimaging.com  
 Website: www.leopardimaging.com

## Water Proof

- Metal Housing
- Water-proof M12 lens
- Sealed Gasket (White)
- Sealed O-ring (Red)

Note: The lens must be glued for water-proof.



## Cable Connector

- Housing Connector- FAKRA Z Type
- Cable length: 3 meters  
Support single Coax Cable transmit up to 12 meters
- Cable Part#: FAK-SMZSMZ-3M
- FAKRA type connectors



Leopard Imaging Inc.

48820 Kato Rd, Suite 100B, Fremont, CA 94538, USA  
Phone: +1-408-263-0988  
Fax: +1-408-217-1960  
Email: [sales@leopardimaging.com](mailto:sales@leopardimaging.com)  
Website: [www.leopardimaging.com](http://www.leopardimaging.com)

## Ordering Information

**Part#: LI-AR0820-GMSL2-xxxH**

Note:

xxxH - 060H: FOV H 60°  
110H: FOV H 110°

LI-AR0820-GMSL2-060H	LI-AR0820-GMSL2-110H
	
<p>Lens: DSL163 Lens EFL: 7.87 mm F/#: 1.8 FOV(D): 68° FOV(H): 59° FOV(V): 32.2° Water-proof: IP67</p>	<p>Lens: CAR-53 Lens EFL: 4.47 mm F/#: 1.6 FOV(D): 125.8° FOV(H): 109.6° FOV(V): 54.8° Water-proof: IP67</p>



Leopard Imaging Inc.

48820 Kato Rd, Suite 100B, Fremont, CA 94538, USA  
Phone: +1-408-263-0988  
Fax: +1-408-217-1960  
Email: sales@leopardimaging.com  
Website: www.leopardimaging.com

## LI-GMSL2-DESER



Front View

## LI-USB30-CNTL



Back View

LI-AR0820-GMSL2 can connect to USB 3.0 EVA module as a USB 3.0 camera.

Part#: **LI-USB30-AR0820-GMSL2-xxxH**

### Key Features

- USB 3.0 Super Speed support
- RAW data output without compression
- UVC compliance
- Provide customization services
- 12VDC Power Supply
- Weight: 86 g
- Single Coax Cable transmit up to 12 meter PoC(Power over Cable)
- Support 3848x2168@3fps
- Power consumption: Approx. 80 mA at 12VDC
- Support Windows, Linux OS and other OS which include UVC drivers

### SDK Supported

- Camera Tool Source Code in C#
- Capture & Display
- Save file as BMP & RAW format



## Revision History

Revision	Description	Release Date
1.0	First Release	11. Jan. 2018
1.1	Update lens information	22. Aug. 2018
1.2	Update the 110H lens to CAR-53	29. Apr. 2019
1.3	Update the 060H lens to DSL163	8. Jul. 2020



Leopard Imaging Inc.

48820 Kato Rd, Suite 100B, Fremont, CA 94538, USA  
Phone: +1-408-263-0988  
Fax: +1-408-217-1960  
Email: [sales@leopardimaging.com](mailto:sales@leopardimaging.com)  
Website: [www.leopardimaging.com](http://www.leopardimaging.com)



## X-ON Electronics

Largest Supplier of Electrical and Electronic Components

*Click to view similar products for [Video IC Development Tools](#) category:*

*Click to view products by [Leopard Imaging](#) manufacturer:*

Other Similar products are found below :

[TW6872-NA1-CR-EVALZ](#) [MAX3815AHDMIEVKIT+ 1937](#) [ADZS-DECODE-EX3](#) [SEN0173](#) [EBK-GS2972-00](#) [LF-PNV-EVN](#) [EP-DCOV2735-F36](#) [UP-PACK-VISION-002](#) [3100](#) [3202](#) [397](#) [EVAL-AD9984AEBZ](#) [EVAL-ADV7180LFEBZ](#) [EVAL-ADV7181CLQEBZ](#) [EVAL-ADV7280EBZ](#) [EVAL-ADV7281MAEBZ](#) [EVAL-ADV7282EBZ](#) [EVAL-ADV7282MEBZ](#) [EVAL-ADV7341EBZ](#) [107784](#) [108024](#) [108025](#) [108320](#) [108329](#) [ME810A-HV35R-BK](#) [VM800BU35A-PL](#) [VM801B43A-BK](#) [VM801B50A-BK](#) [VM801P50A-BK](#) [VM801P43A-BK](#) [DFR0498](#) [ESP-EYE](#) [82535IVCQSPL04N](#) [82634DSQSCR](#) [030-0276-0101\\_A](#) [QC-DB-I10006](#) [DP-VIP-I-EVN](#) [DP-VIP-O-EVN](#) [USB3-VIP-EVN](#) [CS-DEPTHAI-05](#) [CS-DEPTHAI-06](#) [AGB1N0CS-GEVK](#) [PIM365](#) [PIM366](#) [101020892](#) [103990057](#) [114991702](#) [EBK-GS2971A-00](#) [LMH1980MMEVAL/NOPB](#)