

# ABS2 Thru ABS10

## High Current Glass Passivated Molding Single-Phase Bridge Rectifier

Reverse Voltage 200 to 1000V Forward Current 1.0 A

### FEATURES

- Plastic Package has Underwriters Laboratory Flammability Classification 94V-0
- High current capacity with small package
- Glass passivated chip junctions
- Superior thermal conductivity
- High IFSM

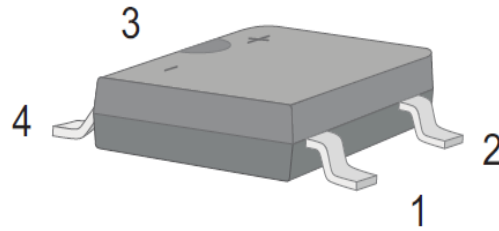

### 1. Maximum & Thermal Characteristics Ratings at 25°C ambient temperature unless otherwise specified.

Parameter Symbol	Symbol	ABS2	ABS4	ABS6	ABS8	ABS10	Unit	
Maximum repetitive voltage	VRRM	200	400	600	800	1000	V	
Maximum RMS Voltage	VRMS	140	280	420	560	700	V	
Maximum DC Blocking Voltage	VDC	200	400	600	800	1000	V	
Maximum DC reverse current TA=25 °C	IR	5						μA
Average rectified output current, @60Hz sine wave, R-load, Ta=40°C, on Alumina Substrate	Io	1.0						A
Peak forward surge current 8.3ms single half sine-wave superimposed on rated load	IFSM	35						A
Rating of fusing (t<8.3ms)	I <sup>2</sup> t	5						A <sup>2</sup> sec
Max instantaneous forward voltage at 1.0A	VF	0.95						V
Thermal Resistance Between junction and ambient on AL substrate	RθJ-A	62.5						°C/W
Thermal Resistance Between junction and lead	RθJ-L	25						
Operating junction temperature	TJ	-55~150						°C
Storage temperature	Tstg	-55~150						°C

# ABS2 Thru ABS10

## 2. Ratings and Characteristic Curves (TA = 25°C unless otherwise noted)

Fig. 1 Derating Curve

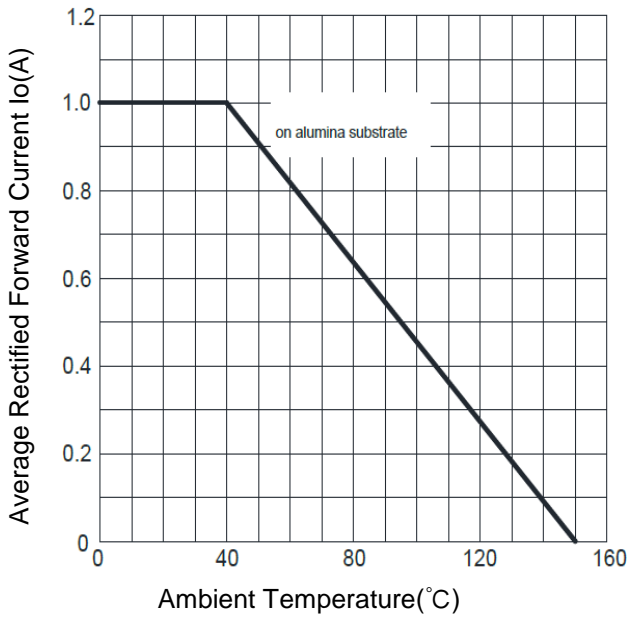

Fig.2 Typical Reverse Characteristics

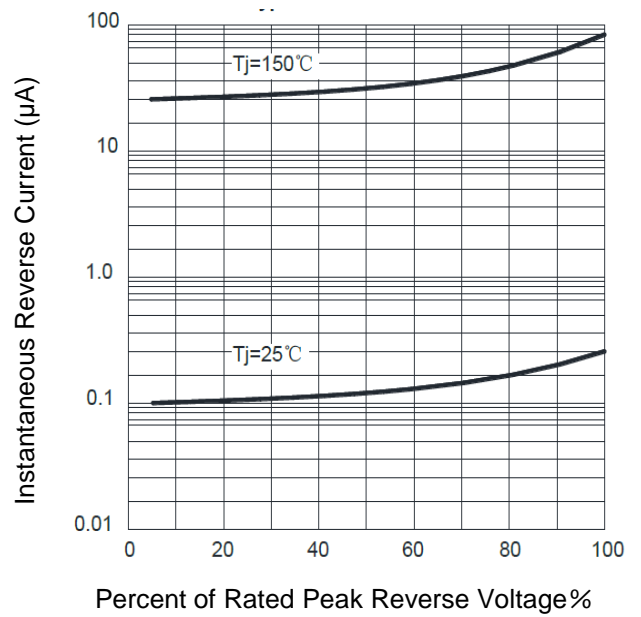

Fig.3 Forward Voltage

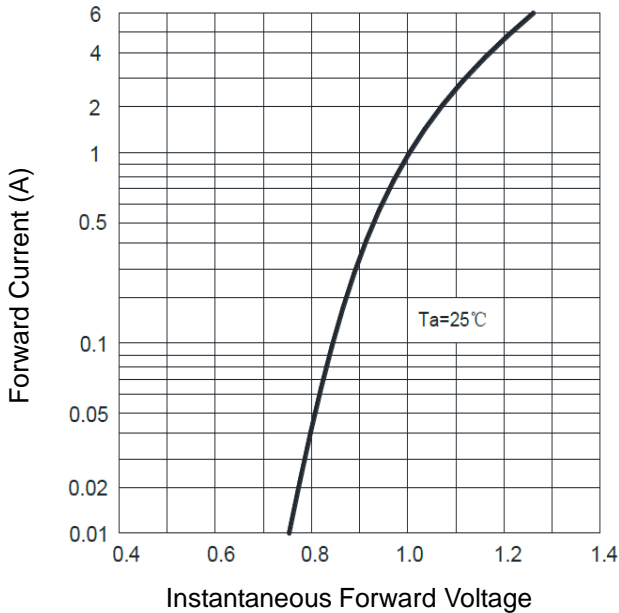
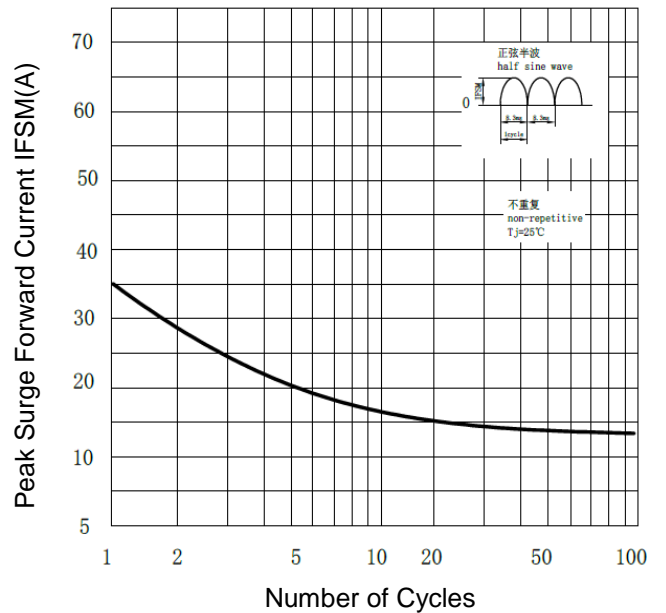
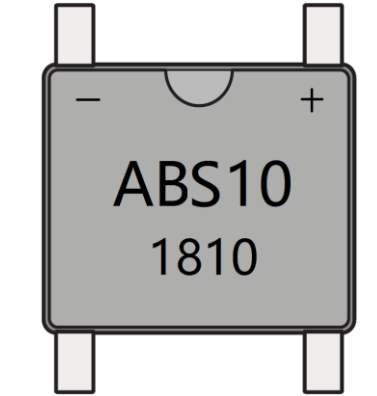

Fig.4 Peak Surge Forward Capability



# ABS2 Thru ABS10

## 3. Marking Identification



**Note:**

生产日期码包含4位数字，例如“1810”，前两个数字“18”表示为2018年，另外二个数字“10”是指第10周，即表示该产品为2018年10周生产。

型号:

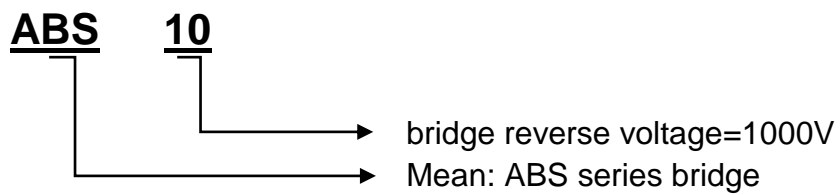

## 4. Dimension(Unit: inch/mm)

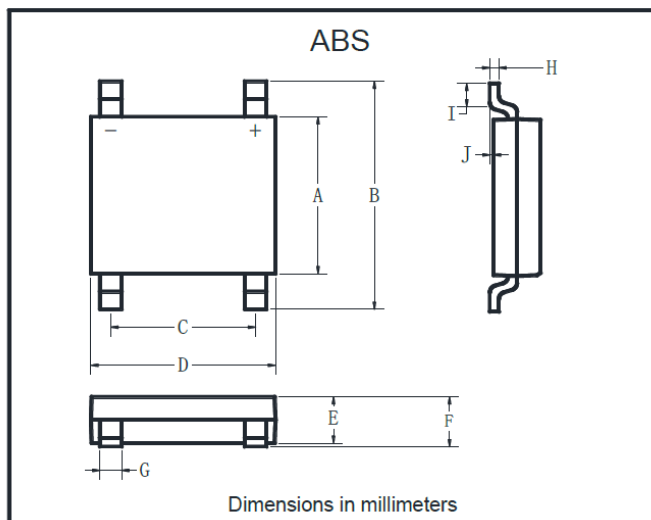

ABS		
Dim	Min	Max
A	4.30	4.50
B	6.00	6.40
C	3.90	4.10
D	4.90	5.10
E	1.25	1.45
F	1.60 Max	
G	0.60	0.70
H	0.15	0.25
I	0.30	0.80
J	0.02	0.15

# ABS2 Thru ABS10

## 5. Standard Soldering Pad (Unit: mm/mil)

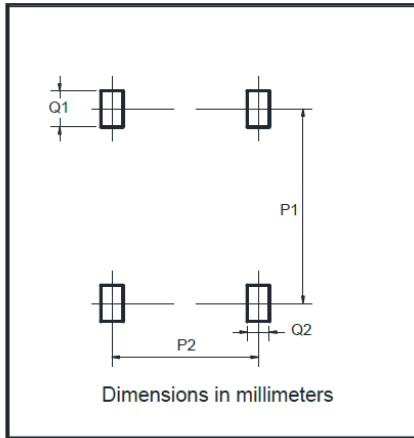

Dim	Min
P1	5.72
P2	4.00
Q1	1.00
Q2	0.90

## X-ON Electronics

Largest Supplier of Electrical and Electronic Components

*Click to view similar products for [Bridge Rectifiers](#) category:*

*Click to view products by [Leshan](#) manufacturer:*

Other Similar products are found below :

[MB252](#) [MB356G](#) [MB358G](#) [GBJ1504-BP](#) [GBU10B-BP](#) [GBU15K-BP](#) [GBU4A-BP](#) [GBU4D-BP](#) [DB101-BP](#) [DF01](#) [DF10SA-E345](#) [KBPC50-10S](#) [RS405GL-BP](#) [GBJ1502-BP](#) [GBU6M](#) [TB102M](#) [MB1510](#) [MB86](#) [TL401G](#) [MDA920A2](#) [TU602](#) [TU810](#) [MP5010W-BP](#) [MP501W-BP](#) [MP502-BP](#) [KBPC25-02](#) [VBO160-12NO7](#) [VS-110MT120KPBF](#) [VS-60MT80KPBF](#) [DB105-BP](#) [DF1510S](#) [VS-40MT160PAPBF](#) [GBU4G-BP](#) [GSIB15A80-E3/45](#) [DB104-BP](#) [D3SB60](#) [TB354](#) [GBJ2504-BP](#) [26MB100A](#) [B1S-G](#) [VS-40MT160KPBF](#) [VUO162-16NO7](#) [ABS10-G](#) [GBU6B-BP](#) [GBJ1508-BP](#) [BR5010-G](#) [ABS6-G](#) [B125C800G-E4/51](#) [MSB15MH-13](#) [LBS10-13](#)