

LMBR120ET1G thru LMBR1200ET1G

Schottky Barrier Rectifiers

Reverse Voltage 20 to 200V Forward Current 1.0A

FEATURES

- * Plastic package has Underwriters Laboratory Flammability Classification 94V-0
- * Low power loss, high efficiency
- * For use in low voltage high frequency inverters, free wheeling, and polarity protection applications
- * Guardring for over voltage protection
- * High temperature soldering guaranteed: 260°C/10 seconds at terminals

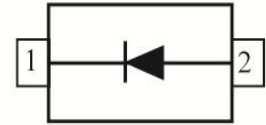
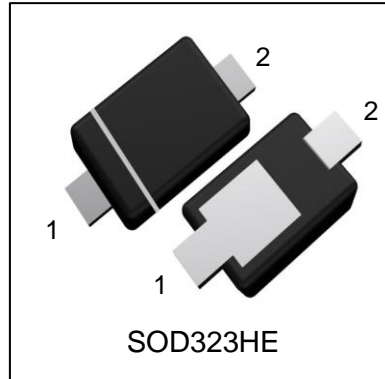

Mechanical Data

Case: SOD-323HE

molded plastic over sky die

Terminals: Tin Plated, solderable per

MIL-STD-750, Method 2026

Polarity: Color band denotes cathode end

Mounting Position Any

Weight: 0.0053 g

Handling precaution None

We declare that the material of product is Halogen free (green epoxy compound)

1. Electrical Characteristic

Maximum & Thermal Characteristics Ratings at 25°C ambient temperature unless otherwise specified.

Parameter Symbol	symbol	LMBR 120ET1G	LMBR 130ET1G	LMBR 140ET1G	LMBR 150ET1G	LMBR 160ET1G	LMBR 180ET1G	LMBR 1100ET1G	LMBR 1150ET1G	LMBR 1200ET1G	Unit	
device marking code		12	13	14	15	16	18	110	115	120		
Maximum repetitive peak reverse voltage	V_{RRM}	20	30	40	50	60	80	100	150	200	V	
Maximum RMS voltage	V_{RMS}	14	21	28	35	42	56	70	105	140	V	
Maximum DC blocking voltage	V_{DC}	20	30	40	50	60	80	100	150	200	V	
Maximum average forward rectified current at $T_c = 75^\circ\text{C}$	$I_{F(AV)}$	1.0									A	
Peak forward surge current 8.3ms single half sine-wave superimposed on rated load (JEDEC Method)	I_{FSM}	22									A	
Typical thermal resistance (Note 1)	$R_{\theta JA}$ $R_{\theta JL}$	210 70										$^\circ\text{C/W}$
Operating junction temperature range	T_J	-55 to +125					-55 to +150					$^\circ\text{C}$
storage temperature range	T_{STG}	-55 to +150									$^\circ\text{C}$	

Electrical Characteristics Ratings at 25°C ambient temperature unless otherwise specified.

Parameter Symbol	symbol	LMBR 120ET1G	LMBR 130ET1G	LMBR 140ET1G	LMBR 150ET1G	LMBR 160ET1G	LMBR 180ET1G	LMBR 1100ET1G	LMBR 1150ET1G	LMBR 1200ET1G	Unit
Maximum instantaneous forward voltage at ($I_F = 0.7\text{ A}$, $T_J = 25^\circ\text{C}$) ($I_F = 1.0\text{ A}$, $T_J = 25^\circ\text{C}$)	V_F	0.48 0.55			0.68		0.85		0.9 0.92		V
Maximum DC reverse current at rated DC blocking voltage $T_A = 25^\circ\text{C}$ $T_J = 125^\circ\text{C}$	I_R	0.25 10	0.13 10	0.03 10							mA
Typical junction capacitance at 4.0V, 1MHz	C_J	160									PF

NOTES:

1. 8.0mm² (.013mm thick) land areas

LMBR120ET1G thru LMBR1200ET1G

2. Ratings and Characteristic Curves (TA = 25°C unless otherwise noted)

Fig. 1 - Forward Current Derating Curve

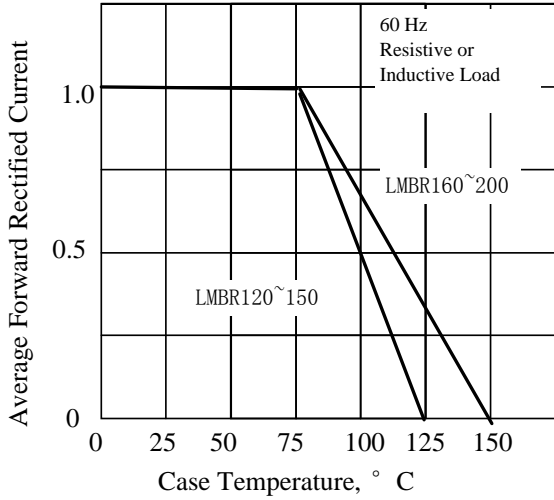

Fig. 2 - Maximum Non-repetitive Peak Forward Surge Current

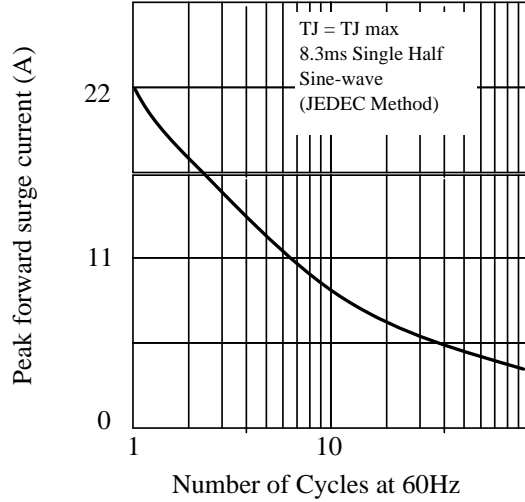

Fig. 3 - Typical Instantaneous Forward Characteristics

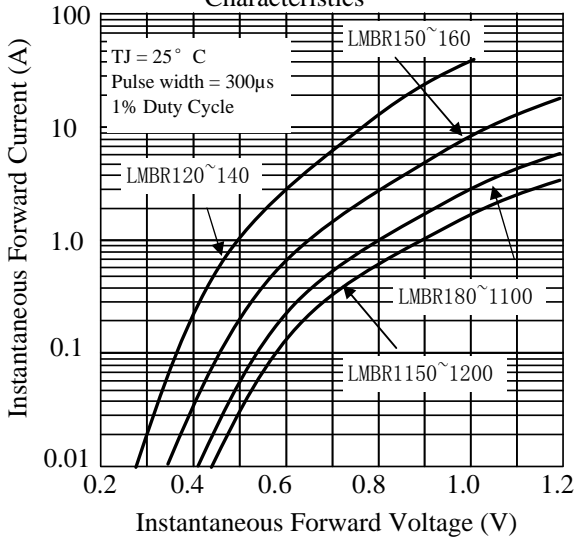

Fig. 4 - Typical Reverse Characteristics

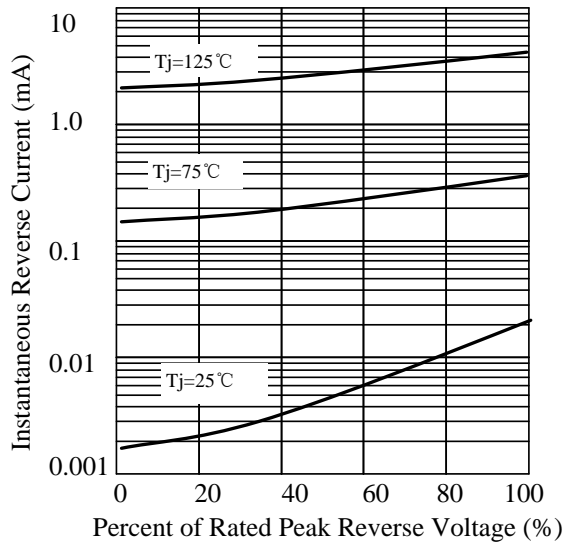

Fig. 5 - typical transient thermal impedance

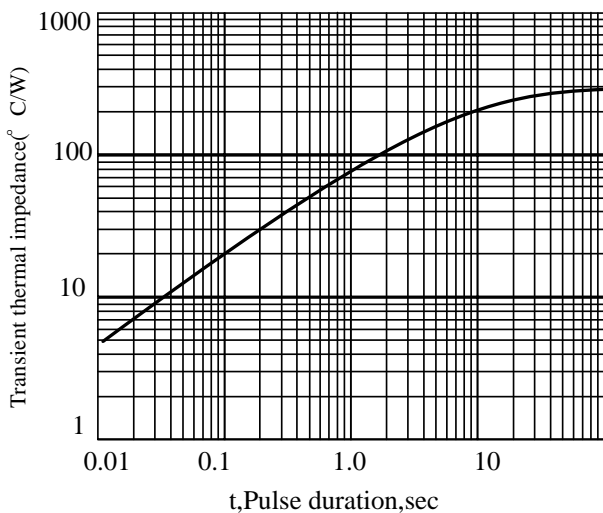
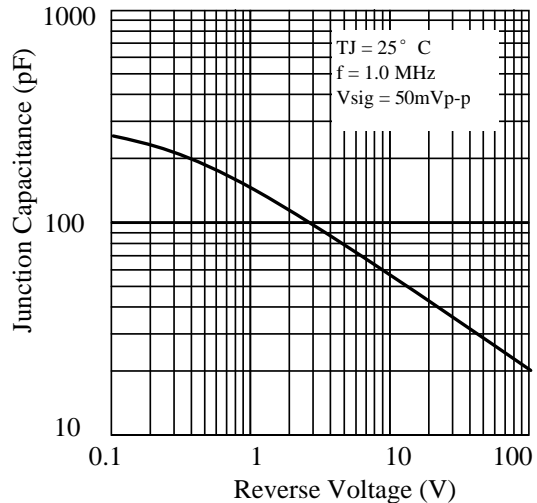
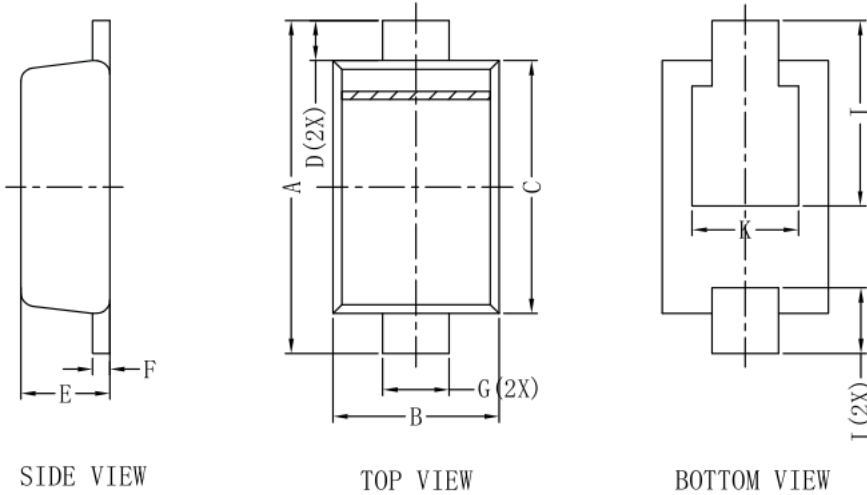

Fig. 6 - Typical Junction Capacitance



LMBR120ET1G thru LMBR1200ET1G

3. OUTLINE AND DIMENSIONS



SOD323HE			
DIM	MIN	MAX	Typ.
A	2.30	2.70	2.55
B	1.20	1.35	1.25
C	1.75	1.95	1.90
D	-	-	0.30
E	0.55	0.75	0.67
F	0.10	0.20	0.15
G	0.45	0.65	0.50
I	0.40	0.70	0.50
J	1.15	1.55	1.40
K	-	-	0.80
All Dimensions in mm			

GENERAL NOTES

1. Top package surface finish $Ra0.4 \pm 0.2 \mu m$
2. Bottom package surface finish $Ra0.7 \pm 0.2 \mu m$

4. SOLDERING FOOTPRINT

RECOMMENDED PAD

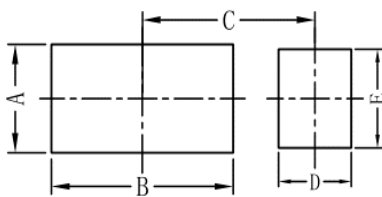

SOD323HE	
DIM	(mm)
A	1.1
B	2.0
C	1.9
D	0.8
E	1.0

COMPATIBLE PAD

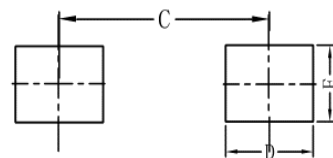

SOD323HE	
DIM	(mm)
D	1.0
E	0.8
C	2.4

LMBR120ET1G thru LMBR1200ET1G

5. Suggested thermal profile for soldering process

1. Storage environment : Temperature=5~40°C Humidity=55±25%
2. Reflow soldering of surface-mount device

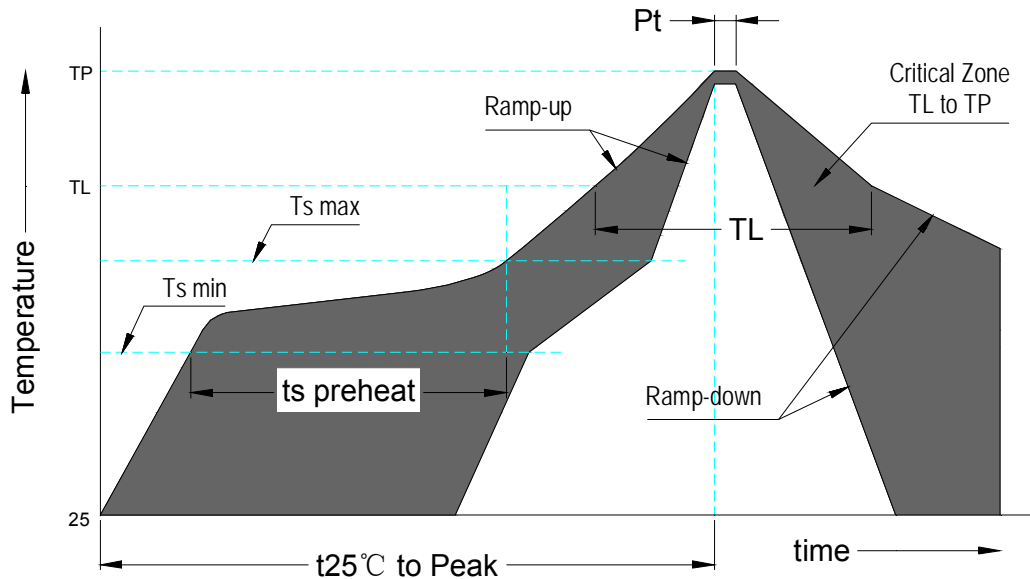

3. Reflow soldering

Profile Feature	Soldering Condition
Average ramp-up rate(T_L to T_P)	<3°C/sec
Preheat	
- Temperature Min(T_{smin})	150°C
- Temperature Max(T_{smax})	200°C
- Time(min to max)(t_s)	60~120sec
T_{smax} to T_L	
- Ramp-up Rate	<3sec
Time maintained above:	
- Temperature (T_L)	217°C
- Time(t_L)	60-260sec
Peak Temperature(T_P)	255 -0/+5°C
Time within 5°C of actual Peak Temperature(T_P)	10~30sec
Ramp-down Rate	<6°C/sec
Time 25°C to Peak Temperature	<6minutes

LMBR120ET1G thru LMBR1200ET1G

6.High reliability test capabilities

Item Test	Condition	Reference
Solder Resistance	at 260±5°C for 10±2sec immerse	MIL-STD-750D METHOD-2031
Solderability	at 245±5°C for 5 sec	MIL-STD-202F METHOD-208
High Temperature Reverse Bias	V _R =80% rate at T _j =125°C for 168hrs	MIL-STD-750D METHOD-1038
Forward Operation Life	Rated average rectifier current	MIL-STD-750D METHOD-1027
Intermittent Operation Life	T _A =25°C , I _F =I _O	MIL-STD-750D METHOD-1036
Pressure Cooker	15P _{SIG} at T _A =121°C for 4hrs	JESD22-A102
Temperature Cycling	-55°C to +125°C dwelled for 30 min. and transferred for 5min. Total 10 cycles	MIL-STD-750D METHOD-1051
Thermal Shock	0°C for 5min. Rise to 100°C for 5min. Total 10 cycles	MIL-STD-750D METHOD-1056
Forward Surge	8.3ms single half sine-wave superimposed on rated load,one surge	MIL-STD-750D METHOD-4066-2
Humidity	at T _A =85°C , RH=85% for 1000hrs	MIL-STD-750D METHOD-1021
High Temperature Storage Life	at 150°C for 1000hrs	MIL-STD-750D METHOD-1031

DISCLAIMER

- Before you use our Products, you are requested to carefully read this document and fully understand its contents. LRC shall not be in any way responsible or liable for failure, malfunction or accident arising from the use of any LRC's Products against warning, caution or note contained in this document.
- All information contained in this document is current as of the issuing date and subject to change without any prior notice. Before purchasing or using LRC's Products, please confirm the latest information with a LRC sales representative.

X-ON Electronics

Largest Supplier of Electrical and Electronic Components

Click to view similar products for [Schottky Diodes & Rectifiers](#) category:

Click to view products by [Leshan](#) manufacturer:

Other Similar products are found below :

[MA4E2039](#) [MA4E2508M-1112](#) [MBR1545CT](#) [MMBD301M3T5G](#) [GS1JE-TP](#) [RB160M-50TR](#) [D83C](#) [BAS16E6433HTMA1](#) [BAT 54-02LRH](#)
[E6327](#) [NRVBAF360T3G](#) [NSR05F40QNXT5G](#) [NTE555](#) [JANS1N6640](#) [SK310-T](#) [SK34B-TP](#) [SS3003CH-TL-E](#) [GA01SHT18](#)
[CRS10I30A\(TE85L,QM](#) [MA4E2501L-1290](#) [MBRA140TRPBF](#) [MBRB30H30CT-1G](#) [BAT 15-04R E6152](#) [JANTX1N5712-1](#) [DMJ3940-000](#)
[SB007-03C-TB-E](#) [SK33B-TP](#) [NRVBB20100CTT4G](#) [NRVBM120LT1G](#) [NTSB30U100CT-1G](#) [VS-6CWQ10FNHM3](#) [CRG04\(T5L,TEMQ\)](#)
[ACDBA1100LR-HF](#) [ACDBA1200-HF](#) [ACDBA240-HF](#) [ACDBA3100-HF](#) [CDBQC0530L-HF](#) [CDBQC0240LR-HF](#) [ACDBA260LR-HF](#)
[ACDBA1100-HF](#) [MA4E2502L-1246](#) [10BQ015-M3/5BT](#) [NRVBM120ET1G](#) [CRS08TE85LQM](#) [PMAD1108-LF](#) [B120Q-13-F](#) [1N5819T-G](#)
[B0530WSQ-7-F](#) [PDS1040Q-13](#) [B160BQ-13-F](#) [SDM05U20CSP-7](#)