

1A Bipolar Linear Regulator

LR1117C

DESCRIPTION

LR1117C is a series of low dropout three terminal regulators with a dropout of 1.3V at 1A load current. LR1117C features a very low standby current 2mA compared to 5mA of competitor.

Other than a fixed version, $V_{out} = 1.2V, 1.5V, 1.8V, 2.5V, 3.3V, 5V,$ and 12V, LR1117C has an adjustable version, which can provide an output voltage from 1.25 to 12V with only two external resistors.

LR1117C offers thermal shut down and current limit functions, to assure the stability of chip and power system. And it uses trimming technique to guarantee output voltage accuracy within $\pm 2\%$. Other output voltage accuracy can be customized on demand, such as $\pm 1\%$

LR1117C is available in SOT-223, TO-252 power package.

TYPICAL APPLICATION

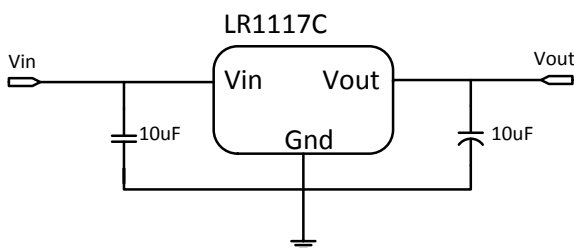

Application circuit of LR1117C fixed version

NOTE: Input capacitor ($C_{in}=10\mu F$) and Output capacitor ($C_{out}=10\mu F$) are recommended in all application circuit. Tantalum capacitor is recommended.

FEATURES

- Other than a fixed version and an adjustable version, output value can be customized on demand.
- Maximum output current is 1A
- Range of operation input voltage: Max 12V
- Standby current: 2mA (typ.)
- Line regulation: 0.1%/V (typ.)
- Load regulation: 10mV (typ.)
- Environment Temperature: $-40^{\circ}C \sim 85^{\circ}C$

APPLICATIONS

- Power Management for Computer Mother Board, Graphic Card
- BLD Monitor and BLD TV
- DVD Decode Board
- ADSL Modem
- Post Regulators for Switching Supplies

TYPICAL ELECTRICAL CHARACTERISTIC

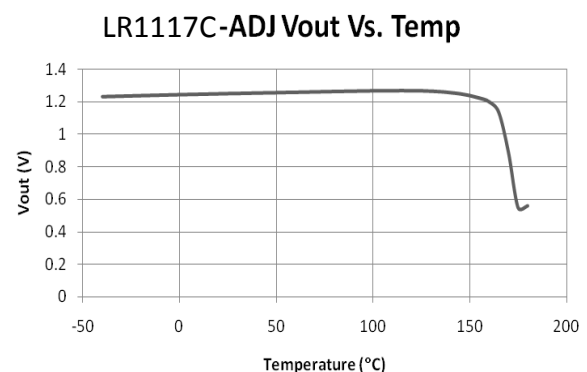

ORDERING INFORMATION

LR117C X XX X

Temp. Range & Rohs Std.
 X: 85C & Pb-free Rohs Std, Output voltage accuracy within $\pm 2\%$

Output Voltage:
 12.....1.2V
 15.....1.5V
 18.....1.8V
 25.....2.5V
 33.....3.3V
 50.....5.0V
ADJ

Package Type:
 S: SOT-223
 D: TO-252

PIN CONFIGURATION AND MARKING

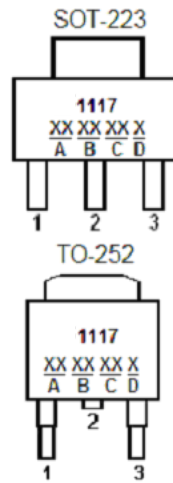

Pin Description:

Fixed Version

Pin No.	Symbol	Definition
1	Gnd	Ground
2	Vout	Output
3	Vin	Input

Adjustable Version

Pin No.	Symbol	Definition
1	Adj.	Adjustable
2	Vout	Output
3	Vin	Input

A: Manufacture weeks **B:** Manufacture LOT No.
C: Output Voltage Value **D:** Temp. Range&Rohs Std

Marking information when ordering quantity is less than 200K

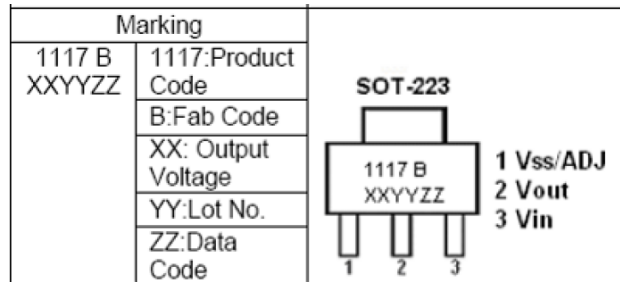

ABSOLUTE MAXIMUM RATING

Parameter		Value
Max Input Voltage		15V ^①
Max Operating Junction Temperature(Tj)		150°C
Ambient Operating Temperature(Ta)		-40°C – 85°C
Package Thermal Resistance	SOT-223	20°C / W
	TO-252	10°C / W
Storage Temperature(Ts)		-40°C - 150°C
Lead Temperature & Time		260°C, 10S

Note: Exceed these limits to damage to the device. Exposure to absolute maximum rating conditions may affect device reliability.

RECOMMENDED WORK CONDITIONS

Parameter	Value
Input Voltage Range	Max. 12V ^①
Operating Junction Temperature(Tj)	-20°C –125°C

^①Exceptional for LR117C -12V, the maximum input voltage for LR117C-12V is 20V.

ELECTRICAL CHARACTERISTICS

Tj=25°C

Symbol	Parameter	Conditions	Min	Typ	Max	Unit
Vref	Reference Voltage	LR1117-ADJ 10mA ≤ Iout ≤ 1A, Vin=3.25V	1.225	1.25	1.275	V
Vout	Output Voltage	LR1117-1.2V 0 ≤ Iout ≤ 1A, Vin=3.2V	1.176	1.2	1.224	V
		LR1117-1.5V 0 ≤ Iout ≤ 1A, Vin=3.5V	1.47	1.5	1.53	V
		LR1117-1.8V 0 ≤ Iout ≤ 1A, Vin=3.8V	1.764	1.8	1.836	V
		LR1117-2.5V 0 ≤ Iout ≤ 1A, Vin=4.5V	2.45	2.5	2.55	V
		LR1117-3.3V 0 ≤ Iout ≤ 1A, Vin=5.3V	3.234	3.3	3.366	V
		LR1117-5.0V 0 ≤ Iout ≤ 1A, Vin=7.0V	4.9	5	5.1	V
		LR1117-12.0V 0 ≤ Iout ≤ 1A, Vin=14V	11.76	12	12.24	V
		ΔVout	Line Regulation	LR1117-1.2V Iout=10mA, 2.7V ≤ Vin ≤ 10V		0.1
LR1117-ADJ Iout=10mA, 2.75V ≤ Vin ≤ 12V				0.1	0.2	%/V
LR1117-1.5V Iout=10mA, 3.0V ≤ Vin ≤ 12V				0.1	0.2	%/V
LR1117-1.8V Iout=10mA, 3.3V ≤ Vin ≤ 12V						
LR1117-2.5V Iout=10mA, 4.0V ≤ Vin ≤ 12V				0.1	0.2	%/V
LR1117-3.3V Iout=10mA, 4.8V ≤ Vin ≤ 12V				0.1	0.2	%/V
LR1117-5.0V Iout=10mA, 6.5V ≤ Vin ≤ 12V				0.1	0.2	%/V
LR1117-12.0V Iout=10mA, 13.5V ≤ Vin ≤ 20V				0.1	0.2	%/V
ΔVout	Load Regulation	LR1117-1.2V Vin = 2.7V, 10mA ≤ Iout ≤ 1A		10	30	mV
		LR1117-ADJ Vin = 2.75V, 10mA ≤ Iout ≤ 1A		10	30	mV
		LR1117-1.5V Vin=3.0V, 10mA ≤ Iout ≤ 1A		10	30	mV
		LR1117-1.8V Vin=3.3V, 10mA ≤ Iout ≤ 1A				
		LR1117-2.5V Vin=4.0V, 10mA ≤ Iout ≤ 1A		10	30	mV
		LR1117-3.3V Vin=4.8V, 10mA ≤ Iout ≤ 1A		10	30	mV
		LR1117-5.0V Vin=6.5V, 10mA ≤ Iout ≤ 1A		10	30	mV
		LR1117-12.0V Vin=13.5V, 10mA ≤ Iout ≤ 1A		10	30	mV

ELECTRICAL CHARACTERISTICS continued

T_j=25°C

Symbol	Parameter	Conditions	Min	Typ	Max	Unit
Vdrop	Dropout Voltage	I _{out} =100mA		1.23	1.3	V
		I _{out} =1A		1.3	1.5	V
I _{limit}	Current Limit	V _{in} -V _{out} =2V, T _j =25°C	1			A
SVR	Supply Voltage Rejection	f = 120Hz, V _{IN} - V _{OUT} = 3V + 1VPP Ripple		60		dB
I _{min}	Minimum Load Current	LR1117-ADJ		2	10	mA
I _q	Quiescent Current	LR1117-1.2V, V _{in} =10V		2	5	mA
		LR1117-1.5V, V _{in} =11V		2	5	mA
		LR1117-1.8V, V _{in} =12V		2	5	mA
		LR1117-2.5V, V _{in} =12V		2	5	mA
		LR1117-3.3V, V _{in} =12V		2	5	mA
		LR1117-5.0V, V _{in} =12V		2	5	mA
		LR1117-12.0V, V _{in} =20V		2	5	mA
I _{Adj}	Adjust Pin Current	LR1117-ADJ V _{in} =5V, 10mA ≤ I _{out} ≤ 1A		55	120	uA
I _{change}	I _{adj} change	LR1117-ADJ V _{in} =5V, 10mA ≤ I _{out} ≤ 1A		0.2	10	uA
ΔV/ΔT	Temperature coefficient			±100		ppm
θ _{JC}	Thermal Resistance	SOT-223		20		°C/W
		TO-252		10		
θ _{JA}	Thermal Resistance Junction-to-Ambient (No air flow)	SOT-223 (No heat sink)		136		°C/W
		TO-252 (No heat sink)		92		

Note1: All test are conducted under ambient temperature 25°C and within a short period of time 20ms

Note2: Load current smaller than minimum load current of LR1117C-ADJ will lead to unstable or oscillation output.

BLOCK DIAGRAM

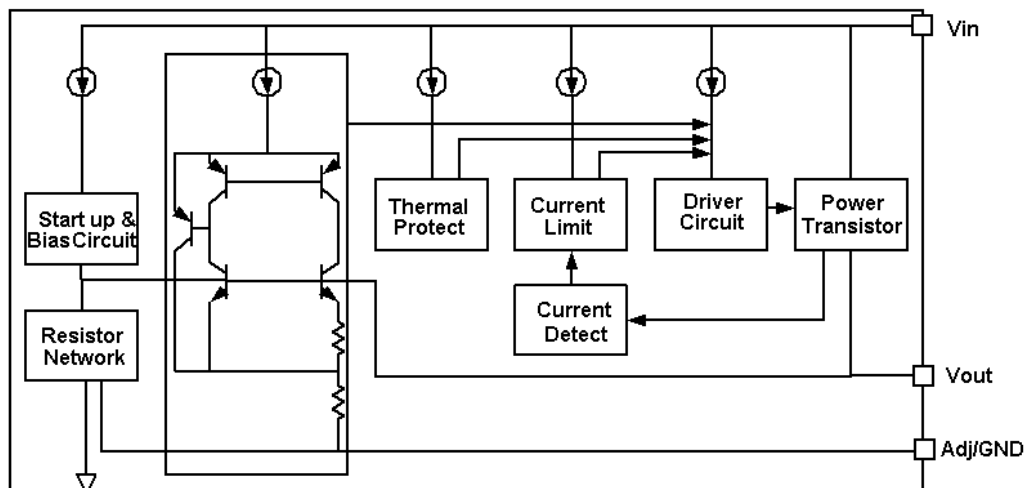

DETAILED DESCRIPTION

LR1117C is a series of low dropout voltage, three terminal regulators. Its application circuit is very simple: the fixed version only needs two capacitors and the adjustable version only needs two resistors and two capacitors to work. It is composed of some modules including start-up circuit, bias circuit, bandgap, thermal shutdown, current limit, power transistors and its driver circuit and so on.

The thermal shut down modules can assure chip and its application system working safety when the junction temperature is larger than 140°C.

The bandgap module provides stable reference voltage, whose temperature coefficient is compensated by careful design considerations. The temperature coefficient is under 100 ppm/°C. And the accuracy of output voltage is guaranteed by trimming technique.

TYPICAL APPLICATION

LR1117C has an adjustable version and six fixed versions (1.2V, 1.5V, 1.8V, 2.5V, 3.3V, 5V and 12V)

Fixed Output Voltage Version

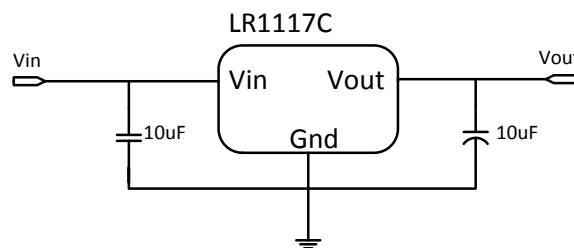

Application circuit of LR1117C fixed version

- 1) Recommend using 10uF tan capacitor as bypass capacitor (C1) for all application circuit.
- 2) Recommend using 10uF tan capacitor to assure circuit stability.

Adjustable Output Voltage Version

LR1117C-ADJ provides a 1.25V reference voltage. Any output voltage between 1.25V~12V can be achievable by choosing two external resistors (schematic is shown below), R1 and R2

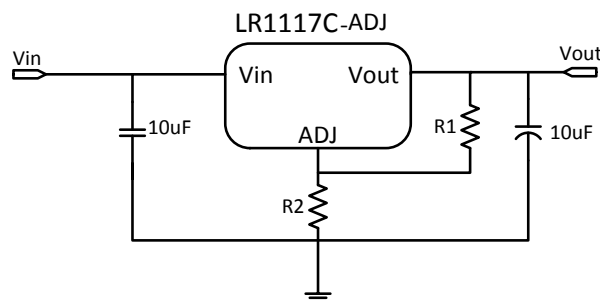

Application Circuit of LR1117C-ADJ

The output voltage of adjustable version follows the equation: $V_{out} = 1.25 \times (1 + R2/R1) + I_{Adj} \times R2$. We can ignore I_{Adj} because I_{Adj} (about 50uA) is much less than the current of R1 (about 2~10mA).

- 1) To meet the minimum load current (>10mA) requirement, R1 is recommended to be 125ohm or lower. As LR117C-ADJ can keep itself stable at load current about 2mA, R1 is not allowed to be higher than 625ohm.
- 2) Using a bypass capacitor (C_{ADJ}) between the ADJ pin and ground can improve ripple rejection. This bypass capacitor prevents ripple from being amplified as the output voltage is increased. The impedance of C_{ADJ} should be less than R1 to prevent ripple from being amplified. As R1 is normally in the range of $100\Omega \sim 500\Omega$, the value of C_{ADJ} should satisfy this equation: $1/(2\pi \times f_{ripple} \times C_{ADJ}) < R1$.

THERMAL CONSIDERATIONS

We have to take heat dissipation into great consideration when output current or differential voltage of input and output voltage is large. Because in such cases, the power dissipation consumed by LR117 is very large. LR117 series uses SOT-223 package type and its thermal resistance is about $20^{\circ}\text{C}/\text{W}$. And the copper area of application board can affect the total thermal resistance. If copper area is $5\text{cm} \times 5\text{cm}$ (two sides), the resistance is about $30^{\circ}\text{C}/\text{W}$. So the total thermal resistance is about $20^{\circ}\text{C}/\text{W} + 30^{\circ}\text{C}/\text{W}$. We can decrease total thermal resistance by increasing copper area in application board. When there is no good heat dissipation copper are in PCB, the total thermal resistance will be as high as $120^{\circ}\text{C}/\text{W}$, then the power dissipation of LR117 could allow on itself is less than 1W. And furthermore, LR117 will work at junction temperature higher than 125°C under such condition and no lifetime is guaranteed.

TYPICAL PERFORMANCE CHARACTERISTICS

$T=25^{\circ}\text{C}$ unless specified.

Line Regulation

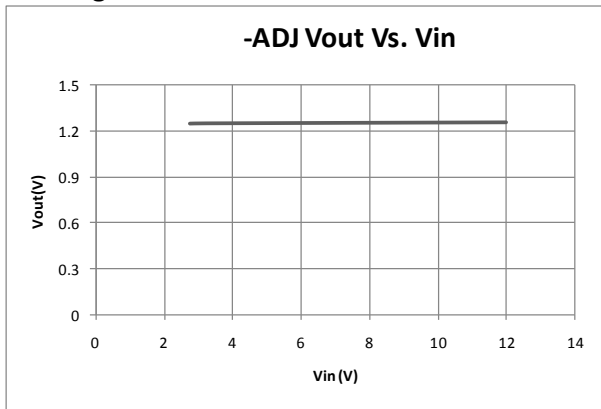

Load Regulation

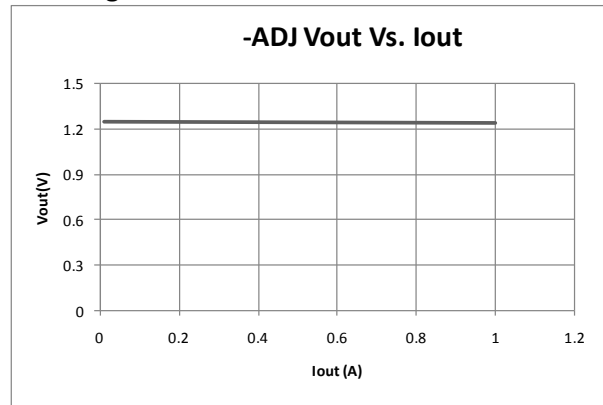

Dropout Voltage

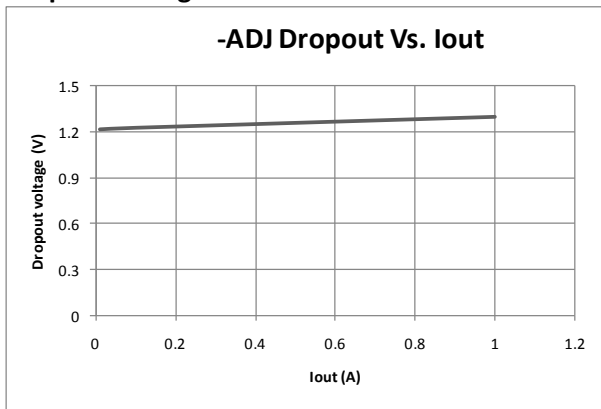

Thermal performance with OTP

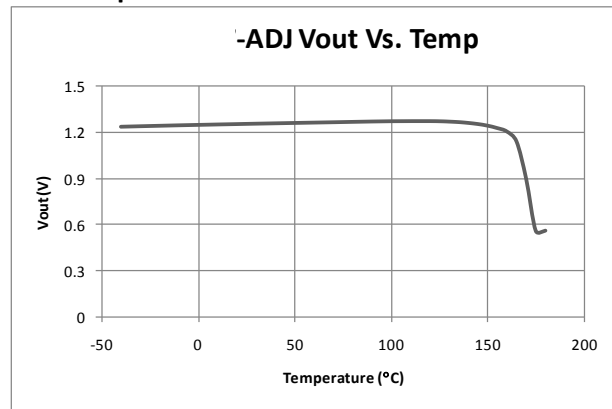

PACKAGE OUTLINE

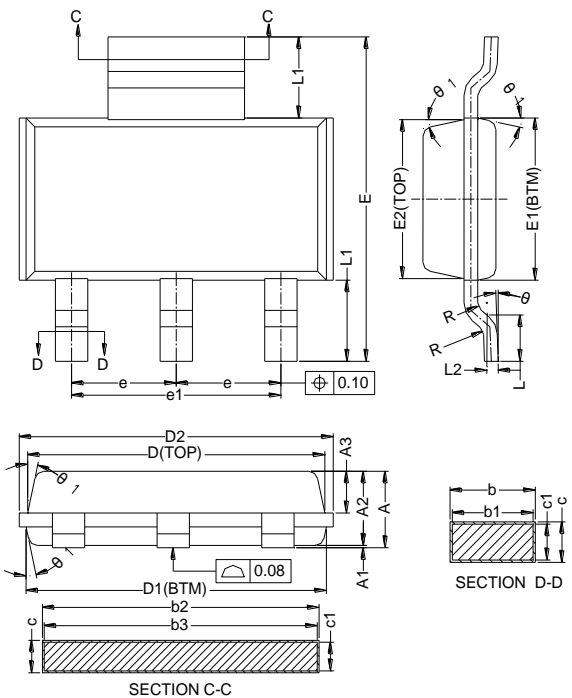
Package	SOT-223	Devices per reel	2500	Unit	mm																																																																																																								
Package spec	 <p>COMMON DIMENSIONS (UNITS OF MEASURE=MILLIMETER)</p> <table border="1"> <thead> <tr> <th>SYMBOL</th> <th>MIN</th> <th>NOM</th> <th>MAX</th> </tr> </thead> <tbody> <tr><td>A</td><td>-</td><td>-</td><td>1.80</td></tr> <tr><td>A1</td><td>0.02</td><td>-</td><td>0.10</td></tr> <tr><td>A2</td><td>1.50</td><td>1.60</td><td>1.70</td></tr> <tr><td>A3</td><td>0.80</td><td>0.90</td><td>1.00</td></tr> <tr><td>b</td><td>0.67</td><td>-</td><td>0.80</td></tr> <tr><td>b1</td><td>0.66</td><td>0.71</td><td>0.76</td></tr> <tr><td>b2</td><td>2.96</td><td>-</td><td>3.09</td></tr> <tr><td>b3</td><td>2.95</td><td>3.00</td><td>3.05</td></tr> <tr><td>c</td><td>0.30</td><td>-</td><td>0.35</td></tr> <tr><td>c1</td><td>0.29</td><td>0.30</td><td>0.31</td></tr> <tr><td>D</td><td>6.48</td><td>6.53</td><td>6.58</td></tr> <tr><td>D1</td><td>6.55</td><td>6.60</td><td>6.65</td></tr> <tr><td>D2</td><td>-</td><td>-</td><td>7.05</td></tr> <tr><td>E</td><td>6.80</td><td>-</td><td>7.20</td></tr> <tr><td>E1</td><td>3.40</td><td>3.50</td><td>3.60</td></tr> <tr><td>E2</td><td>3.33</td><td>3.43</td><td>3.53</td></tr> <tr><td>e</td><td colspan="3">2.30BSC</td></tr> <tr><td>e1</td><td colspan="3">4.60BSC</td></tr> <tr><td>L</td><td>0.80</td><td>1.00</td><td>1.20</td></tr> <tr><td>L1</td><td colspan="3">1.75REF</td></tr> <tr><td>L2</td><td colspan="3">0.25BSC</td></tr> <tr><td>R</td><td>0.10</td><td>-</td><td>-</td></tr> <tr><td>R1</td><td>0.10</td><td>-</td><td>-</td></tr> <tr><td>θ</td><td>0°</td><td>-</td><td>8°</td></tr> <tr><td>θ 1</td><td>10°</td><td>12°</td><td>14°</td></tr> </tbody> </table> <p>NOTES: ALL DIMENSIONS REFER TO JEDEC STANDARD TO261-AA</p>					SYMBOL	MIN	NOM	MAX	A	-	-	1.80	A1	0.02	-	0.10	A2	1.50	1.60	1.70	A3	0.80	0.90	1.00	b	0.67	-	0.80	b1	0.66	0.71	0.76	b2	2.96	-	3.09	b3	2.95	3.00	3.05	c	0.30	-	0.35	c1	0.29	0.30	0.31	D	6.48	6.53	6.58	D1	6.55	6.60	6.65	D2	-	-	7.05	E	6.80	-	7.20	E1	3.40	3.50	3.60	E2	3.33	3.43	3.53	e	2.30BSC			e1	4.60BSC			L	0.80	1.00	1.20	L1	1.75REF			L2	0.25BSC			R	0.10	-	-	R1	0.10	-	-	θ	0°	-	8°	θ 1	10°	12°	14°
SYMBOL	MIN	NOM	MAX																																																																																																										
A	-	-	1.80																																																																																																										
A1	0.02	-	0.10																																																																																																										
A2	1.50	1.60	1.70																																																																																																										
A3	0.80	0.90	1.00																																																																																																										
b	0.67	-	0.80																																																																																																										
b1	0.66	0.71	0.76																																																																																																										
b2	2.96	-	3.09																																																																																																										
b3	2.95	3.00	3.05																																																																																																										
c	0.30	-	0.35																																																																																																										
c1	0.29	0.30	0.31																																																																																																										
D	6.48	6.53	6.58																																																																																																										
D1	6.55	6.60	6.65																																																																																																										
D2	-	-	7.05																																																																																																										
E	6.80	-	7.20																																																																																																										
E1	3.40	3.50	3.60																																																																																																										
E2	3.33	3.43	3.53																																																																																																										
e	2.30BSC																																																																																																												
e1	4.60BSC																																																																																																												
L	0.80	1.00	1.20																																																																																																										
L1	1.75REF																																																																																																												
L2	0.25BSC																																																																																																												
R	0.10	-	-																																																																																																										
R1	0.10	-	-																																																																																																										
θ	0°	-	8°																																																																																																										
θ 1	10°	12°	14°																																																																																																										

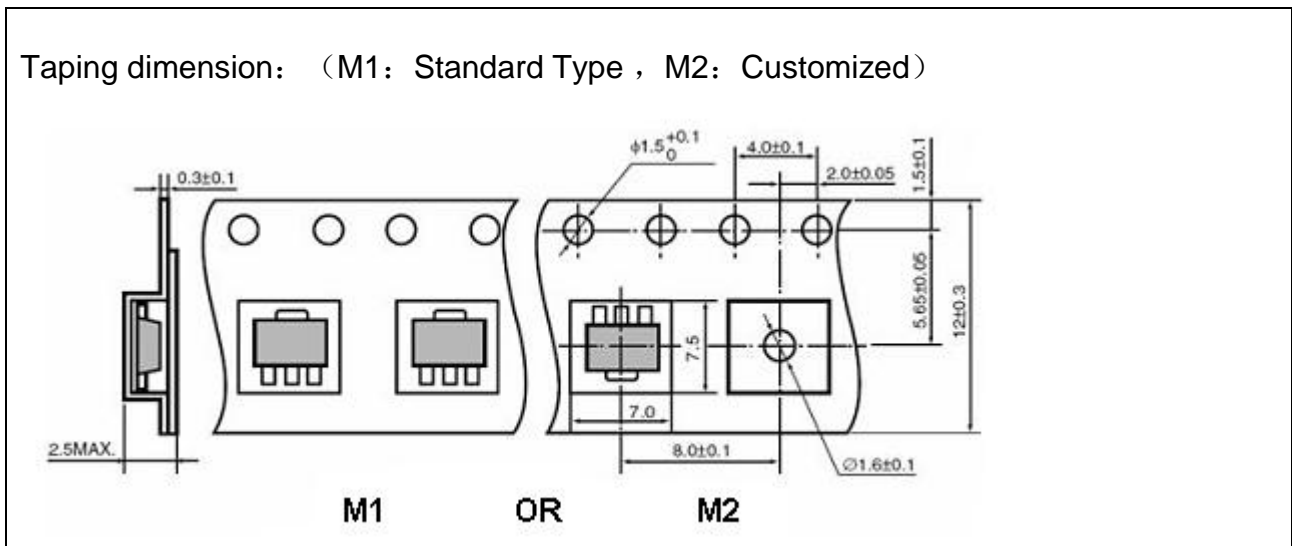

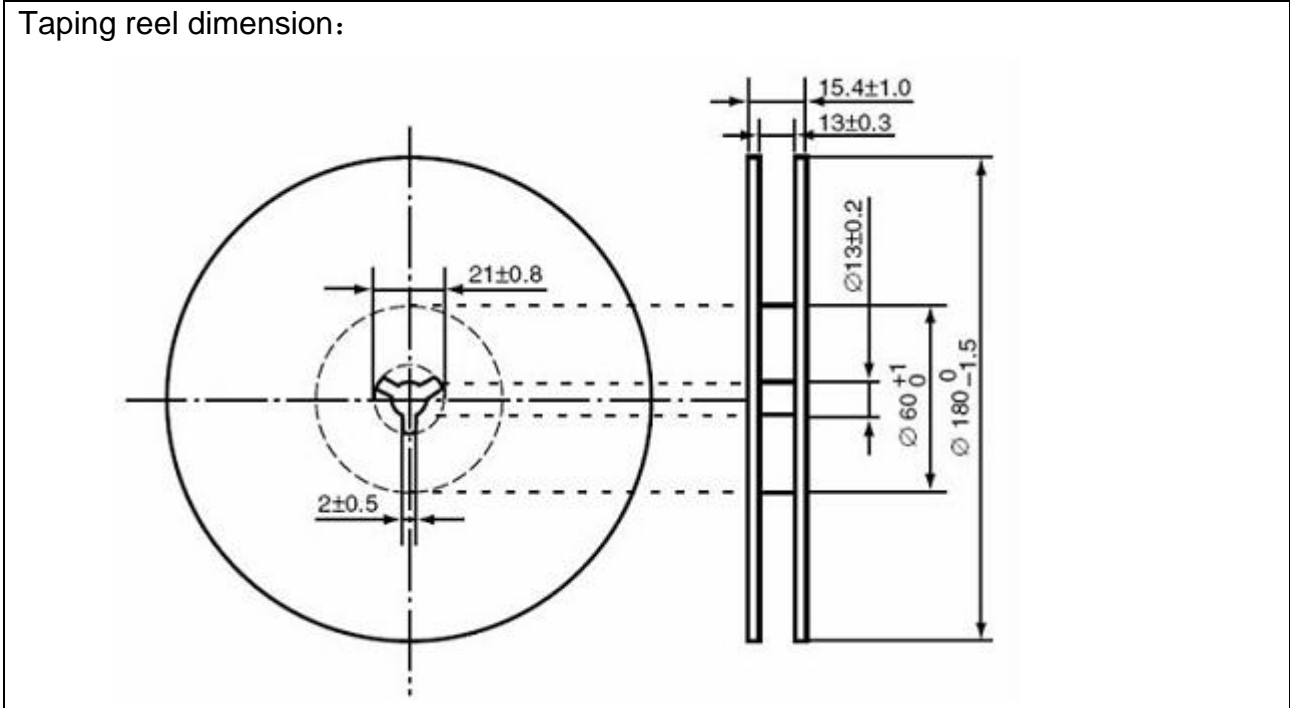

Package	TO-252	Devices per reel	2500	Unit	mm
---------	--------	------------------	------	------	----

Package specification:

SYMBOL	MILLIMETER		
	MIN	NOM	MAX
A1	0	—	0.10
A2	2.20	2.30	2.40
A3	1.02	1.067	1.12
b	0.75	—	0.84
b1	0.74	0.76	0.79
c	0.49	—	0.57
c1	0.48	0.508	0.52
D	6.50	6.60	6.70
D1	5.30REF		
D2	4.70	—	—
E	9.90	10.10	10.30
E1	6.00	6.10	6.20
E2	5.30REF		
e	2.286BSC		
L	1.40	1.50	1.60
L2	0.90	—	1.25
L3	0.60	0.80	1.00
L4	1.60	1.70	1.80
theta	0	—	8°
L/载体尺寸 (mil)	198*133		

SECTION B-B

Taping dimension: (M1: Standard Type , M2: Customized)

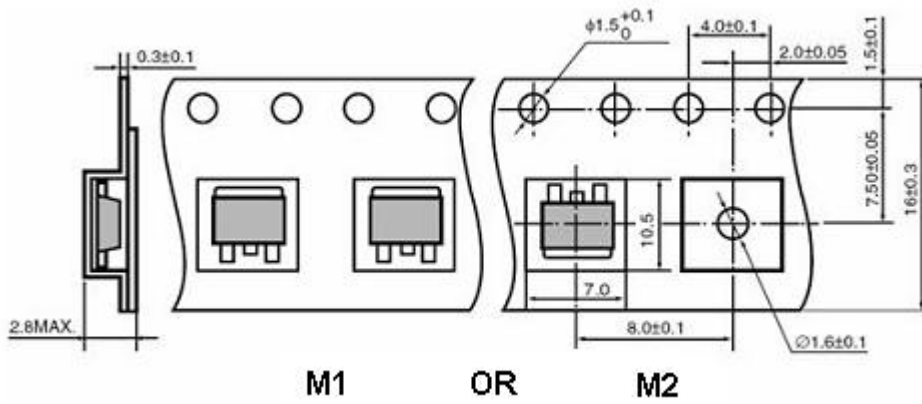

Taping reel dimension:

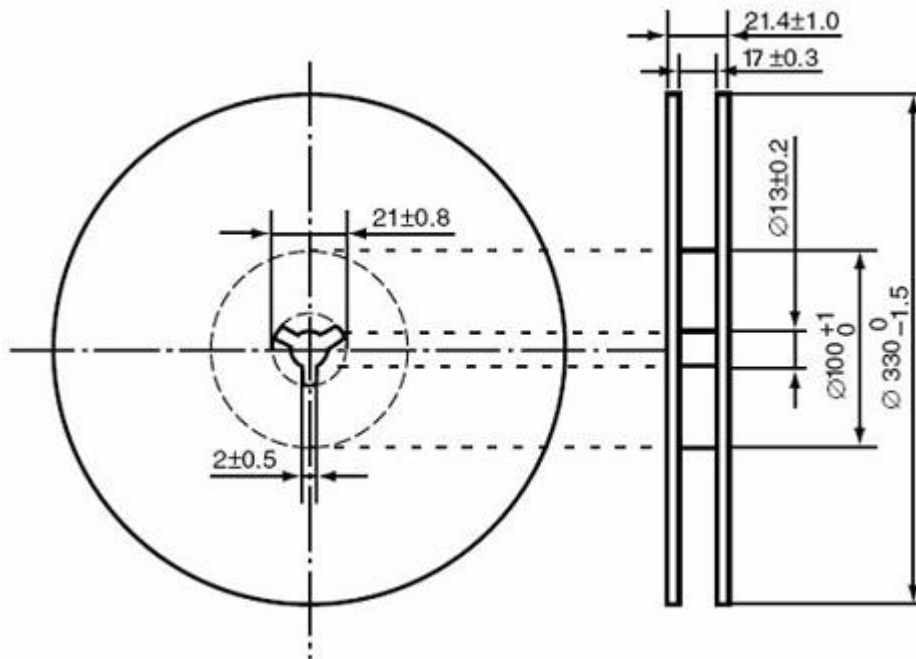

Disclaimer

The product information and the selection guides facilitate the selection of LRC's best suited devices for application in your product(s) as per your requirement. It is recommended that you completely review our Data Sheet(s) so as to confirm that the Device(s) meet the performance parameters for your application. The information furnished on LRC's Website, due to the constraint of time and certain conditions, may not be updated timely and is only for customer's reference. Therefore, LRC does not assume responsibility arising from inaccuracies or incomplete information. If necessary, customer is requested to contact LRC's service support for confirmation and accurate information. Furthermore, LRC does not assume liability whatsoever, arising out of the improper application or use of any LRC product; neither does it convey any license under its patent rights nor rights of other intellectual properties. LRC strives for continuous improvement and reserves the right to change the specifications of its products without prior notice.



No. 287 West People Road, Leshan, Sichuan, China.

Telephone: + 86-833-2150227 Fax: + 86-833-2150003

E-mail: market@lrc.cn Website: www.lrc.cn

X-ON Electronics

Largest Supplier of Electrical and Electronic Components

Click to view similar products for [Linear Voltage Regulators](#) category:

Click to view products by [Leshan](#) manufacturer:

Other Similar products are found below :

[LV56831P-E](#) [LV5684PVD-XH](#) [MCDTSA6-2R](#) [L4953G](#) [L7815ACV-DG](#) [PQ3DZ53U](#) [LV56801P-E](#) [TCR3DF13,LM\(CT](#)
[TCR3DF39,LM\(CT](#) [TLE42794G](#) [L78L05CZ/1SX](#) [L78LR05DL-MA-E](#) [L78MR05-E](#) [033150D](#) [033151B](#) [090756R](#) [636416C](#)
[NCV78M15BDTG](#) [702482B](#) [714954EB](#) [TLE42794GM](#) [TLE42994GM](#) [ZMR500QFTA](#) [BA033LBSG2-TR](#) [NCV78M05ABDTRKG](#)
[NCV78M08BDTRKG](#) [NCP7808TG](#) [NCV571SN12T1G](#) [LV5680P-E](#) [CAJ24C256YI-GT3](#) [L78M15CV-DG](#) [L9474N](#)
[TLS202B1MBV33HTSA1](#) [L79M05T-E](#) [NCP571SN09T1G](#) [MAX15006AASA/V+](#) [MIC5283-5.0YML-T5](#) [L4969URTR-E](#) [L78LR05D-MA-E](#)
[NCV7808BDTRKG](#) [L9466N](#) [NCP7805ETG](#) [SC7812CTG](#) [NCV7809BTG](#) [NCV571SN09T1G](#) [NCV317MBTG](#) [MC78M15CDTT5G](#)
[MC78M12CDTT5G](#) [L9468N](#) [LT1054IS8#TRPBF](#)