

# Dual Operational Amplifier

## LR358/LR2904

### DESCRIPTION

The LR358/LR2904 consists of dual independent, high gain, internally frequency compensated operational amplifiers which were designed specifically to operate from a single power supply over a wide voltage range.

Operation from split power supplies is also possible so long as the difference between the two supplies 3V to 26 V.

Application areas include transducer amplifiers, DC gain blocks and all the conventional OP amp circuits which now can be easily implemented in single power supply systems.

### FEATURES

- \* Internally frequency compensated for unity gain
- \* Large DC voltage gain :100dB
- \* Wide operating supply range( $V_{cc}=3V\sim 26V$  or  $\pm 1.5V\sim \pm 13V$ )
- \* Input common-mode voltage includes ground
- \* Large output voltage swing:From 0V to  $V_{cc}-1.5V$
- \* Power drain suitable for battery operation
- \* Available in SOP-8 package

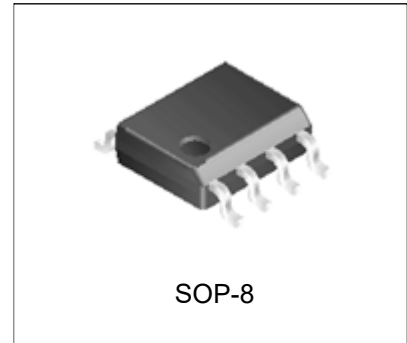

### PIN CONFIGURATION

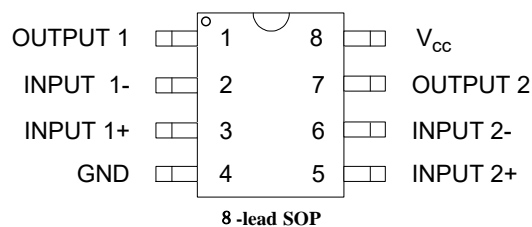

### ORDERING INFORMATION

Device	Package
LR358D	SOP-8
LR2904D	SOP-8

### FUNCTIONAL BLOCK DIAGRAM

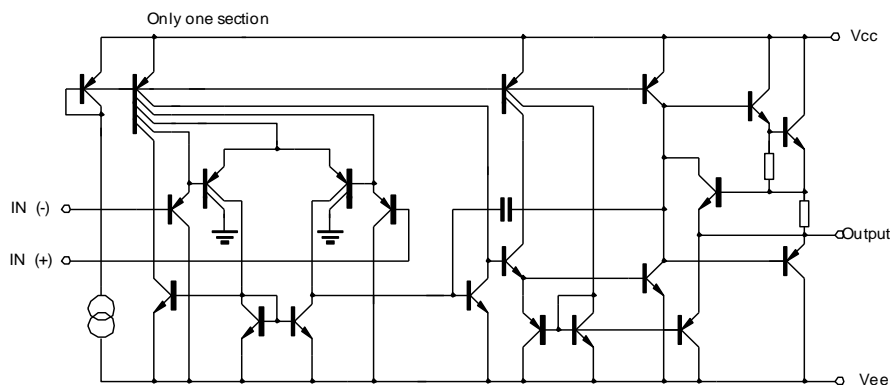

**ABSOLUTE MAXIMUM RATINGS** (Ta=25°C)

Characteristic	Symbol	Value	Unit
Supply Voltage	Vcc	±15or30	V
Differential input voltage	Vi(diff)	26	V
Input Voltage	Vi	-0.3~26	V
Operating Temperature for LR358D	Topr	-20 to +85	°C
Operating Temperature for LR2904D	Topr	-40 to +125	°C
Storage Temperature	Tstg	-65 to 150	°C

**ELECTRICAL CHARACTERISTICS** (Ta=25°C)

(Vcc=5.0V, All voltage referenced to GND unless otherwise specified)

Characteristic	Symbol	Test Condition	Min	Typ.	Max	Unit
Input offset voltage	V <sub>IO</sub>	V <sub>CM</sub> =0 to V <sub>CC</sub> -1.5 V <sub>O(p)</sub> =1.4V, R <sub>S</sub> =0		2	7.0	mV
Input offset current	I <sub>IO</sub>			5	50	nA
Input bias current	I <sub>b</sub>			45	250	nA
Input common-mode voltage range	V <sub>ICM</sub>	V <sub>CC</sub> =25V	0		V <sub>CC</sub> -1.5	V
Supply current	I <sub>CC</sub>	R <sub>L</sub> =∞, V <sub>CC</sub> =25V		0.8	2.0	mA
		V <sub>CC</sub> =5V		0.5	1.2	mA
Large signal voltage gain	G <sub>v</sub>	V <sub>CC</sub> =15V, R <sub>L</sub> =2kΩ V <sub>O(p)</sub> =1V to 11V	25	100		V/mV
Output voltage swing	V <sub>(OH)</sub> V <sub>(OL)</sub>	V <sub>CC</sub> =25V, R <sub>L</sub> =2kΩ	21			V
		V <sub>CC</sub> =25V, R <sub>L</sub> =10kΩ	22	23		V
		V <sub>CC</sub> =5V, R <sub>L</sub> =10kΩ		5	20	mV
Common-mode rejection ratio	CMRR		65	75		dB
Power supply rejection ratio	PSRR		65	100		dB
Channel separation	CS	f=1kHz to 20kHz		120		dB
Output short circuit to GND	I <sub>sc</sub>			40	60	mA
Output current	I <sub>source</sub> I <sub>sink</sub>	V <sub>I(+)</sub> =1V, V <sub>I(-)</sub> =0 V <sub>CC</sub> =15V, V <sub>O(p)</sub> =2V	20	40		mA
		V <sub>I(+)</sub> =0V, V <sub>I(-)</sub> =1V V <sub>CC</sub> =15V, V <sub>O(p)</sub> =2V	10	13		mA
		V <sub>I(+)</sub> =0V, V <sub>I(-)</sub> =1V V <sub>CC</sub> =15V, V <sub>O(p)</sub> =200mV	12	45		μA
Differential input voltage	V <sub>i(diff)</sub>				V <sub>CC</sub>	V
Slew rate	SR	V <sub>I(+)</sub> =10V, V <sub>I(-)</sub> =0V V <sub>CC</sub> =±15V, R <sub>L</sub> =2KΩ, C <sub>L</sub> =100pF		1.0		V/μs

## TYPICAL PERFORMANCE CHARACTERISTICS

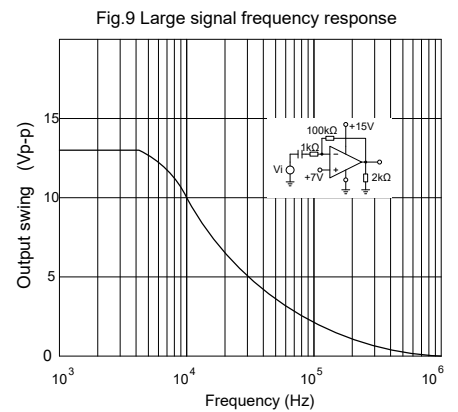
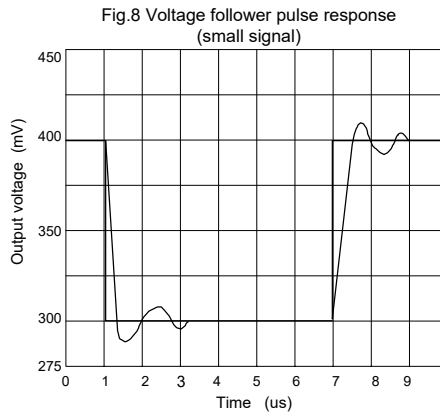
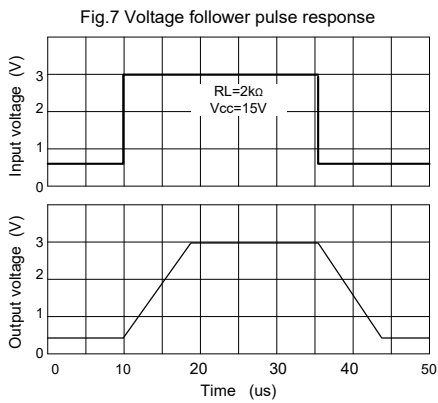
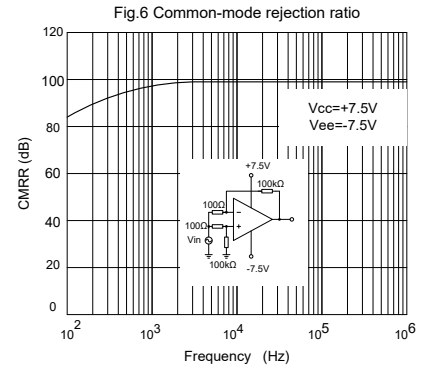
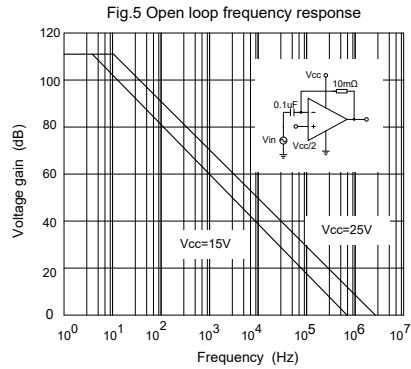
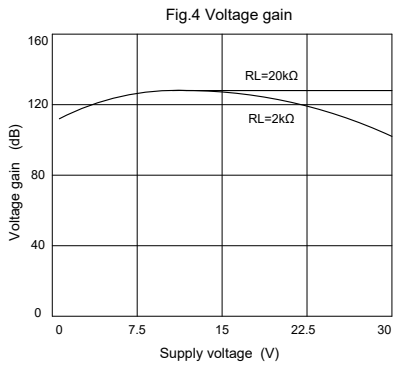
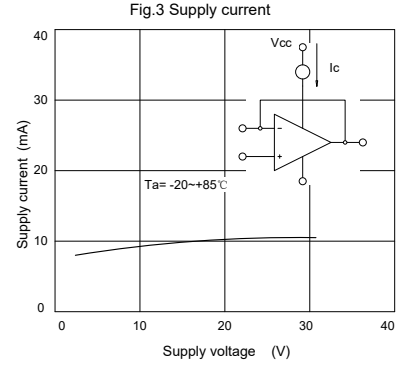
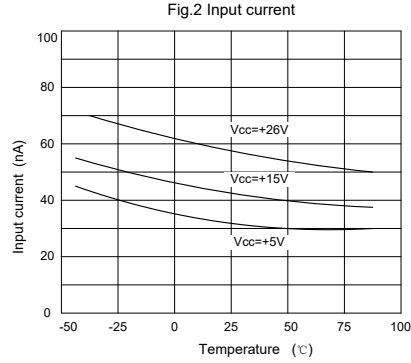
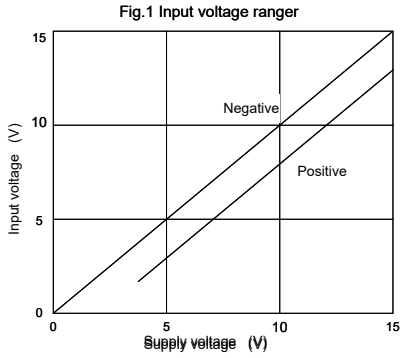

TYPICAL PERFORMANCE CHARACTERISTICS (Continued)

Fig.10 Output characteristics current sourcing

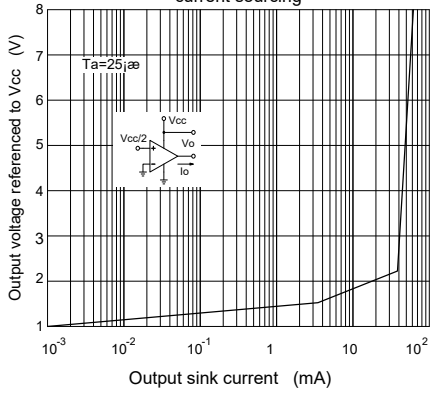

Fig.11 Output characteristics current sinking

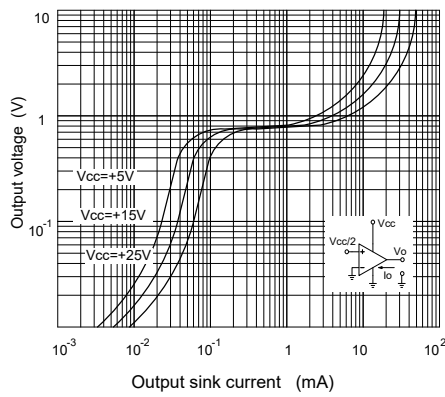

Fig.12 Current limiting

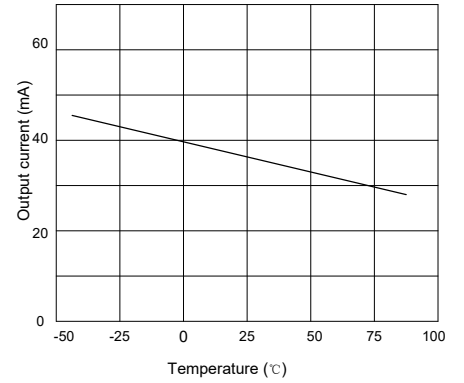
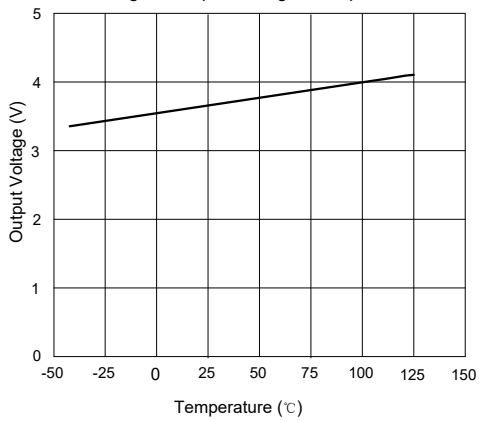

Fig.13 Output Voltage & Temperature



TYPICAL APPLICATION

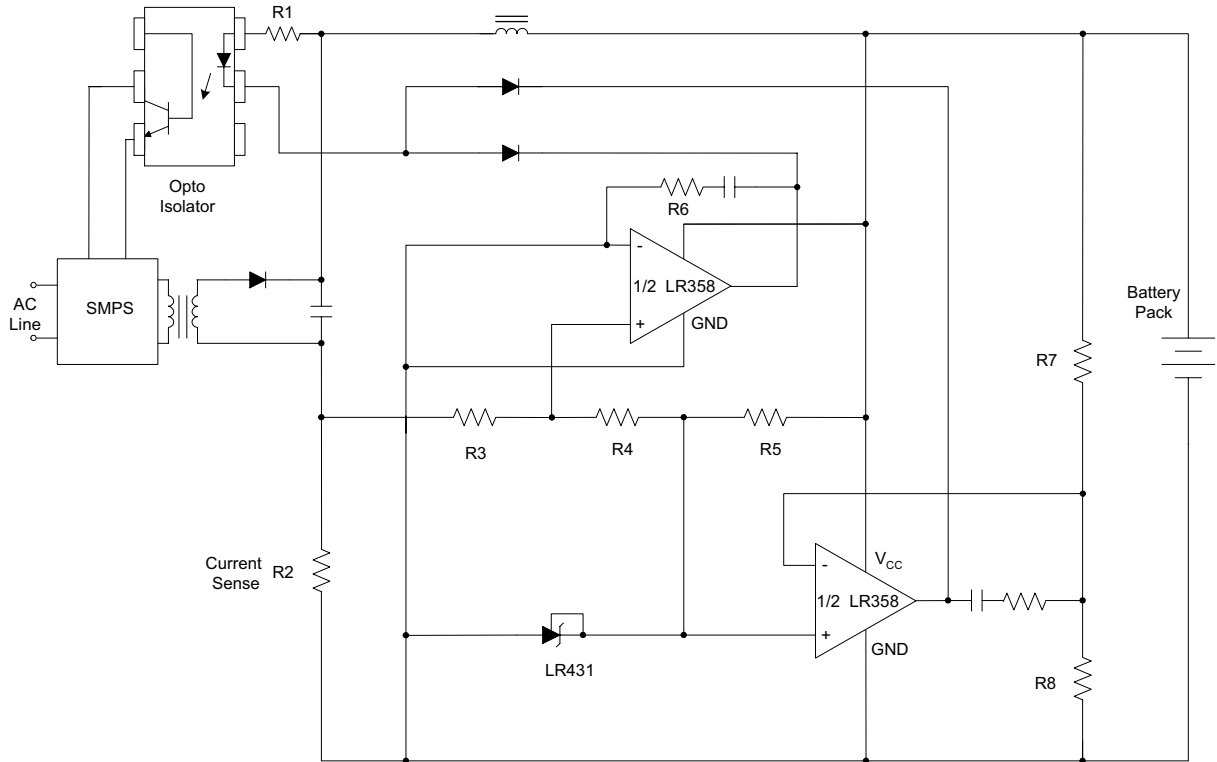

Figure 14. Battery Charger

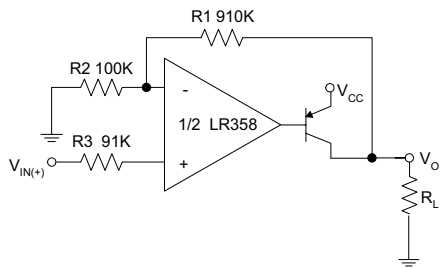

Figure 15. Power Amplifier

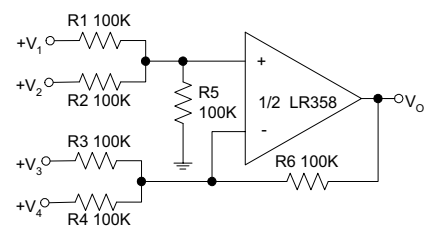

Figure 16. DC Summing Amplifier

MECHANICAL DIMENSIONS

SOP-8

Unit: mm

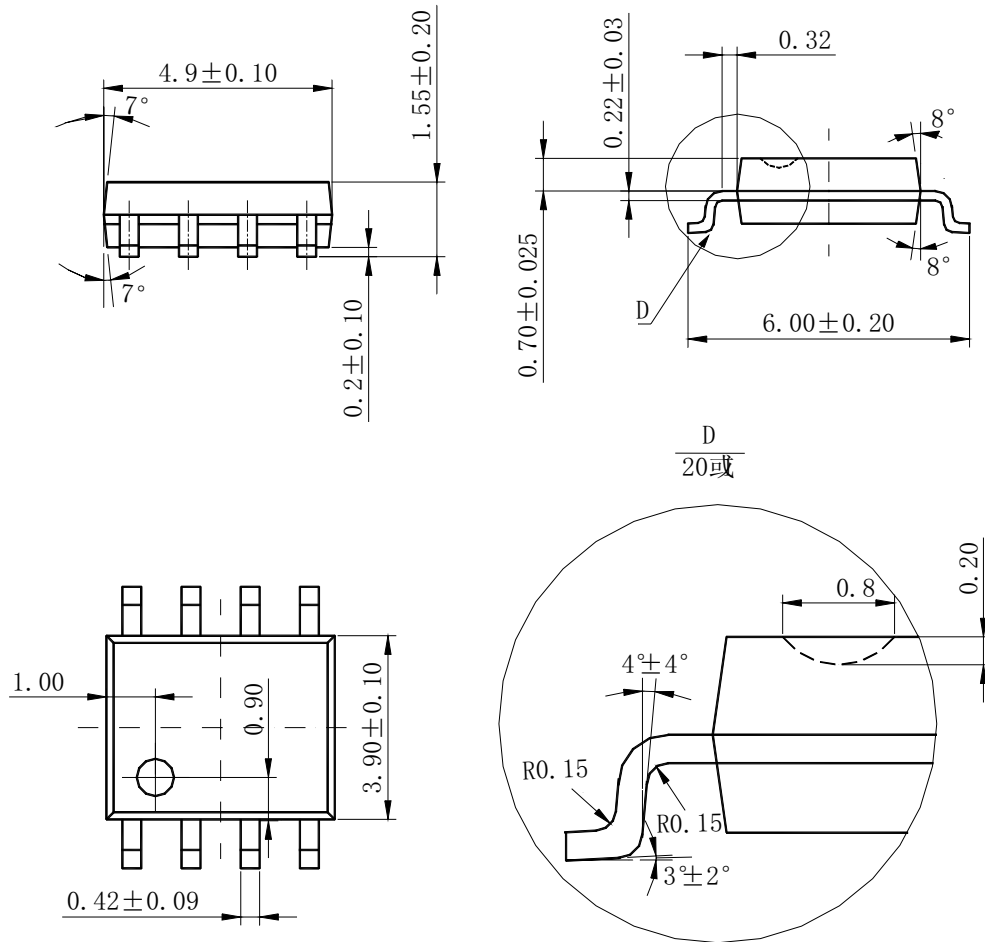

Figure 17. SOP-8 Package Dimension

**DISCLAIMER**

- Before you use our Products, you are requested to carefully read this document and fully understand its contents. LRC shall not be in any way responsible or liable for failure, malfunction or accident arising from the use of any LRC's Products against warning, caution or note contained in this document.
- All information contained in this document is current as of the issuing date and subject to change without any prior notice. Before purchasing or using LRC's Products, please confirm the latest information with a LRC sales representative.

## X-ON Electronics

Largest Supplier of Electrical and Electronic Components

*Click to view similar products for [Operational Amplifiers - Op Amps](#) category:*

*Click to view products by [Leshan](#) manufacturer:*

Other Similar products are found below :

[430227FB](#) [UPC451G2-A](#) [UPC824G2-A](#) [LT1678IS8](#) [042225DB](#) [058184EB](#) [UPC822G2-A](#) [UPC258G2-A](#) [NCS5651MNTXG](#)  
[NCV33202DMR2G](#) [NJM324E](#) [NTE925](#) [5962-9080901MCA\\*](#) [AZV358MTR-G1](#) [AP4310AUMTR-AG1](#) [HA1630D02MMEL-E](#)  
[HA1630S01LPEL-E](#) [AZV358MMTR-G1](#) [SCY33178DR2G](#) [NJU77806F3-TE1](#) [NCV5652MUTWG](#) [NCV20034DR2G](#) [NTE778S](#) [NTE871](#)  
[NTE924](#) [NTE937](#) [MCP6V16UT-E/OT](#) [MCP6V17T-E/MS](#) [MCP6V19T-E/ST](#) [SCY6358ADR2G](#) [NCS20282FCTTAG](#) [LM4565FVT-GE2](#)  
[EL5420CRZ-T7A](#) [TSV772IQ2T](#) [NJM2100M-TE1](#) [COS2262MR](#) [COS2252MR](#) [COS5532SRB](#) [COS2272MR](#) [LMV358MR](#) [COS6002MR](#)  
[LMV358SR](#) [LM358SR](#) [RC4580MM/TR](#) [HGV8544M/TR](#) [HGV8541M/TR](#) [HGV8634M/TR](#) [HGV8542M/TR](#) [HGV8544MT/TR](#)  
[LM2904M/TR](#)