

PROGRAMMABLE PRECISION REFERENCE

LR432ATLT1G

Description

The LR432ATLT1G is a three-terminal adjustable regulator with a guaranteed thermal stability over applicable temperature ranges. The output voltage may be set to any value between V_{REF} (approximately 1.24V) and 18V with two external resistors. It provides very wide applications, including shunt regulator, series regulator, switching regulator, voltage reference and others.



SOT-23 1: Ref; 2: Cathode; 3: Anode

Features:

- Precise Reference Voltage to 1.24V
- Guaranteed 0.5% Reference Voltage Tolerance
- Sink Current Capability, 55 μ A to 100mA
- Quick Turn-on
- Adjustable Output Voltage, $V_o = V_{REF}$ to 18V
- 0.05 Ω Typical Output Impedance
- We declare that the material of product is ROHS compliant and does not contain any Br, Cl, and Sb203
- ESD HBM 7000V

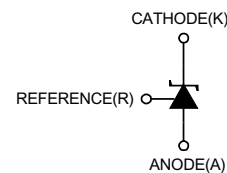
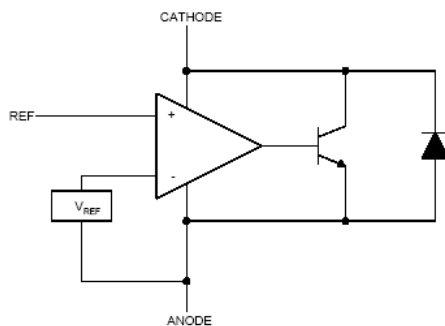

Absolute Maximum Ratings

Symbol	Parameter	Rating	Unit
V_{KA}	Cathode voltage	20	V
I_K	Continuous cathode current range	100	mA
I_{REF}	Reference current range	10	mA
T_j	Operating Junction Temperature Range	150	°C
T_{opr}	Operating Ambient Temperature	- 40 to 125	°C

Electrical Characteristics

 (Typical and limits apply for $T_j=25^\circ\text{C}$ unless otherwise noted.)

Characteristic		Test Circuit	Symbol	Test conditions	MIN	TYP	MAX	UNIT
Reference Voltage	0.5%	3	V_{REF}	$V_{KA}=V_{REF}, I_{KA}=10\text{mA}$	1.234	1.240	1.246	V
	1%				1.228	1.240	1.252	
Deviation of Reference Voltage Over-Temperature		3	ΔV_{REF}	$V_{KA}=V_{REF}$ $I_{KA}=10\text{mA}$	0 to 70°C	2	10	mV
					-20 to 125°C	3	15	
					-40 to 125°C	8	25	
Ratio of Change in VREF to the Change in Cathode Voltage		4	$\frac{\Delta V_{REF}}{\Delta V_{KA}}$	$\Delta V_{KA}: V_{REF}$ to 16V		-0.5	-1.5	mV/V
Reference Input Current		4	I_{REF}	$I_{KA}=10\text{mA}, R1=10\text{K}\Omega, R2=\infty$		0.15	0.4	μA
Deviation of Reference Current Over Full Temperature Range		4	ΔI_{REF}	$I_{KA}=10\text{mA}, R1=10\text{K}\Omega, R2=\infty$ $T_A=-20$ to 85°C		0.1	0.4	μA
Minimum Cathode Current for Regulation		3	$I_{KA(MIN)}$	$V_{KA}=V_{REF}$		55	80	μA
Off-State Cathode Current		5	$I_{KA(OFF)}$	$V_{REF}=0, V_{KA}=18\text{V}$		0.04	0.50	μA
				$V_{KA}=6\text{V}, V_{REF}=0$		0.01	0.05	
Dynamic Impedance		3	Z_{KA}	$V_{KA}=V_{REF}, I_{KA}=1$ to 100mA $f \leq 1.0\text{kHz}$		0.05	0.15	Ω

Classification of Vref and package

Device	Marking	RanK	Vref(V)
LR432ATLT1G	9D	1.0%	1.24
LR432BTLT1G		0.5%	1.24
LR432APTLT1G		1.0%	1.25
LR432BPTLT1G		0.5%	1.25

Package: SOT23

TEST CIRCUIT

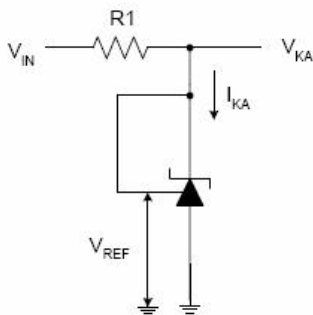

Figure 3 Test Circuit 3 for $V_{KA}=V_{REF}$

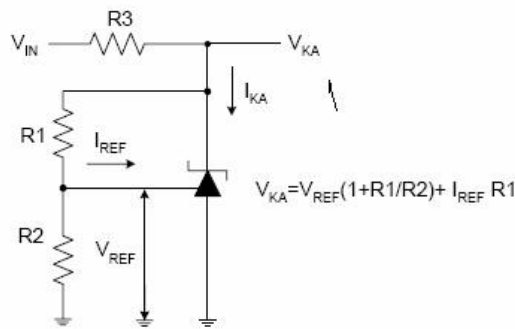

Figure 4. Test Circuit 4 for $V_{KA}>V_{REF}$

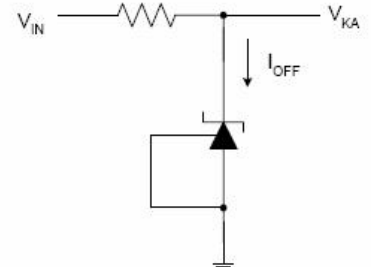

Figure 5. Test Circuit 5 for I_{OFF}

TYPICAL PERFORMANCE CHARACTERISTICS

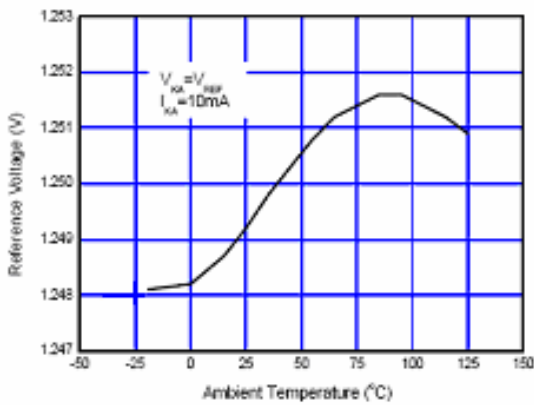

Figure 6. Reference Voltage vs. Ambient Temperature

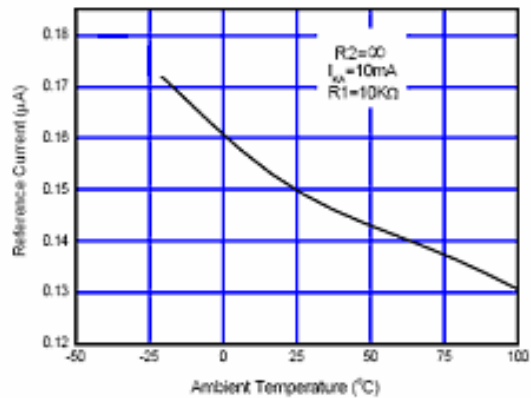

Figure 7. Reference Current vs. Ambient Temperature

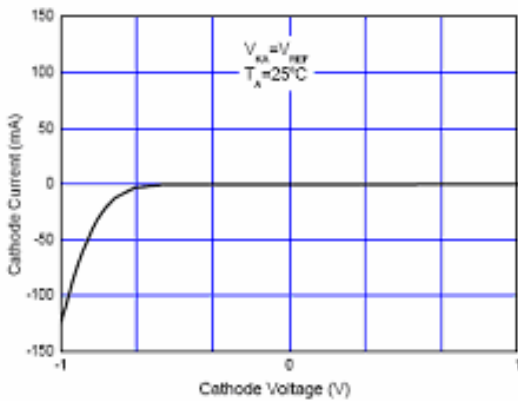

Figure 8. Cathode Current vs. Cathode Voltage

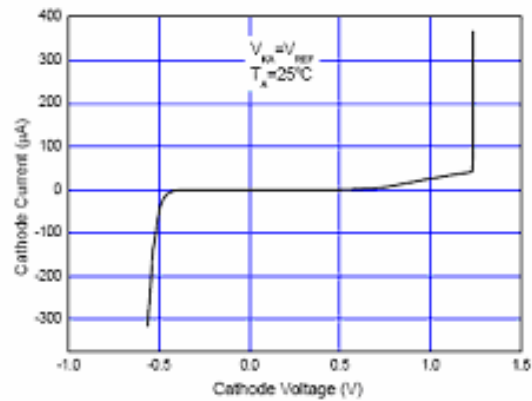

Figure 9. Current vs. cathode Voltage

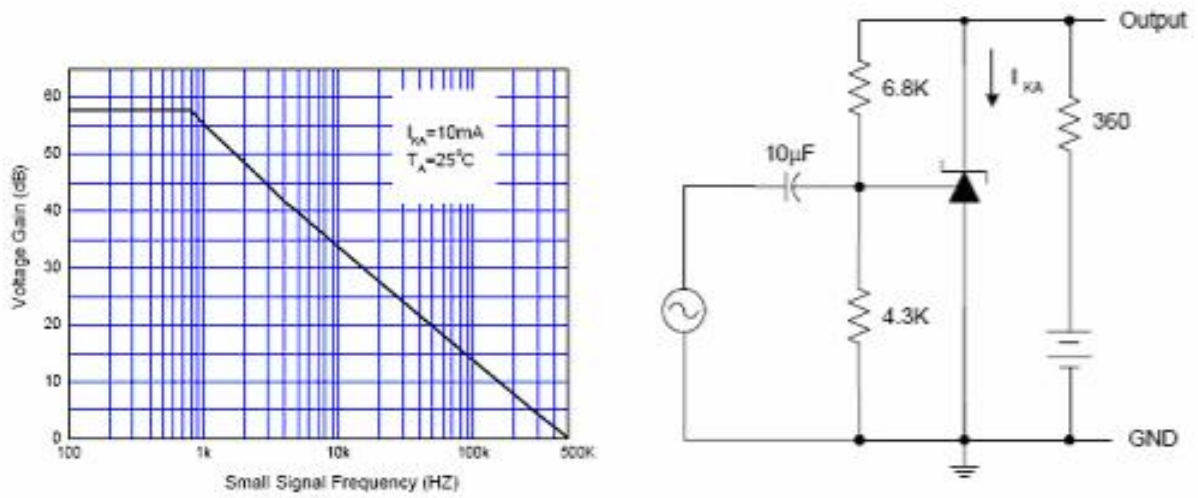

Figure 10. Small Signal Voltage Gain vs. Frequency

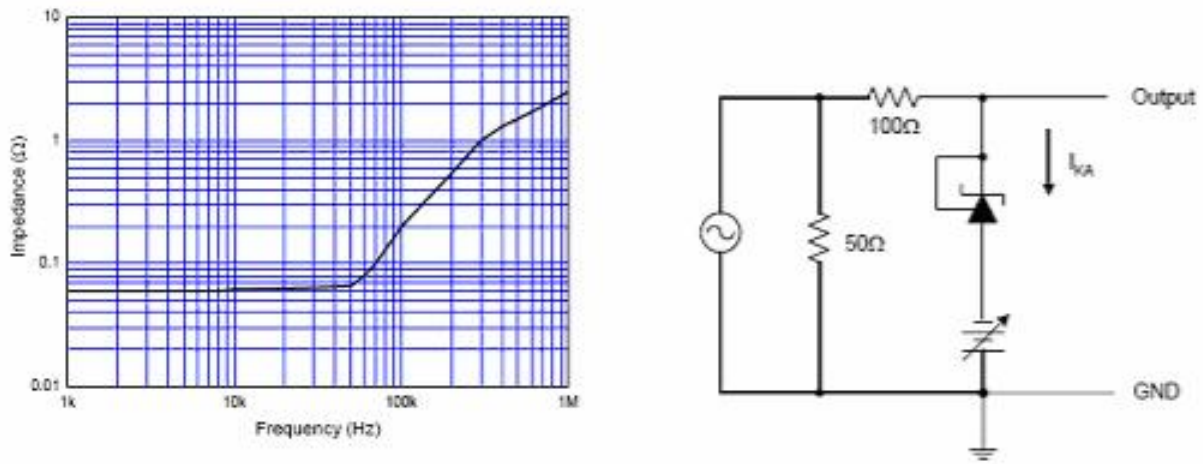

Figure 11. Dynamic Impedance vs. Frequency

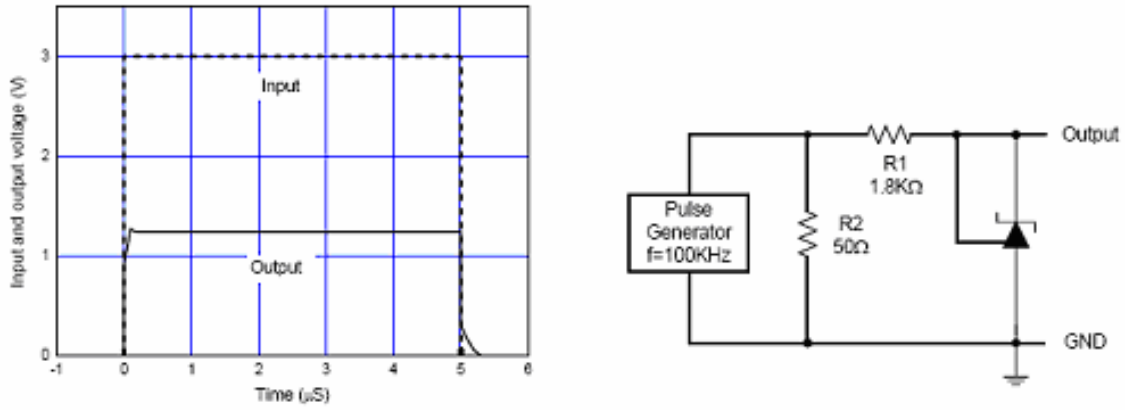

Figure 12. Pulse Response of Input and Output Voltage

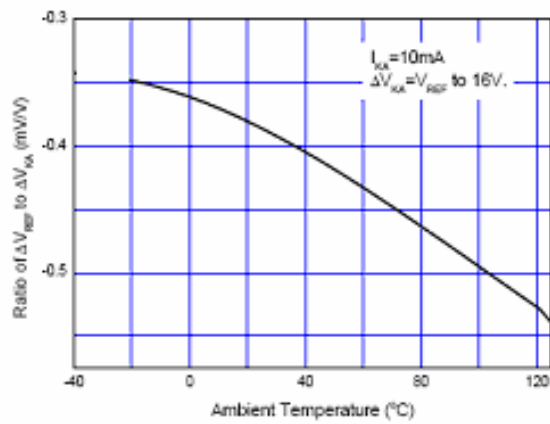

Figure 13. Ratio of Delta Reference Voltage to the Ratio of Delta Cathode Voltage vs. Ambient Temperature

TYPICAL APPLICATIONS

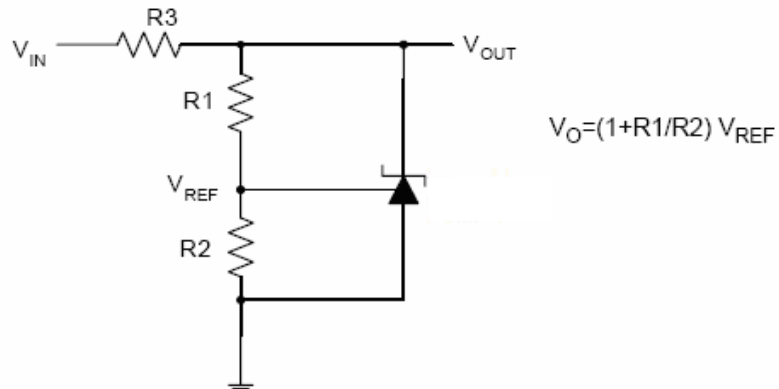

Figure 14: Shunt Regulator

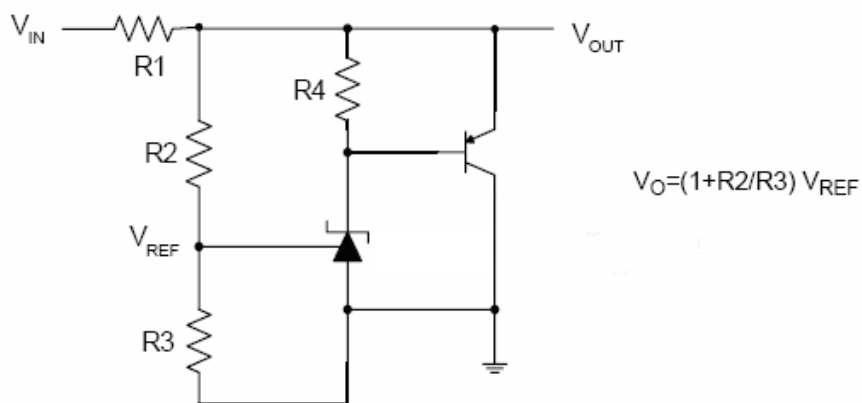

Figure 15: High Current Shunt Regulator

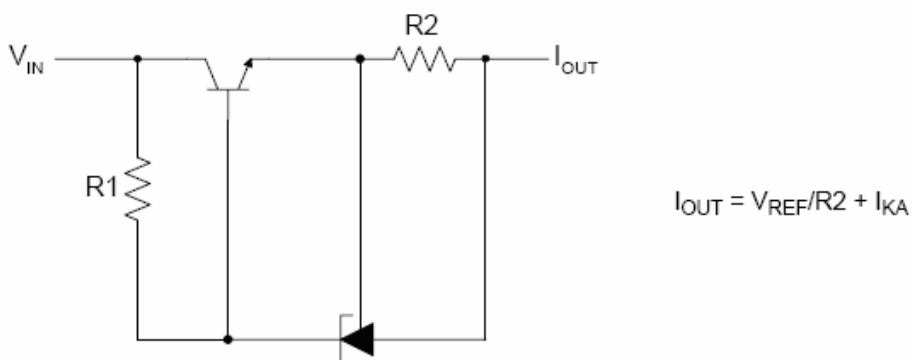

Figure 16: Current Source or Current Limit

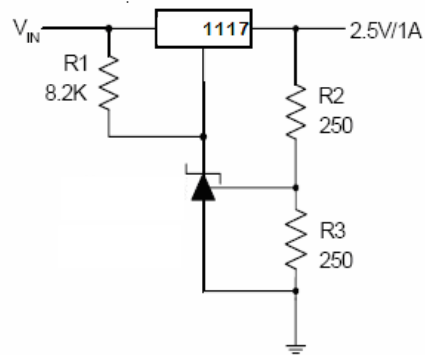

Figure 17 Precision 2.5V/1A Regulator

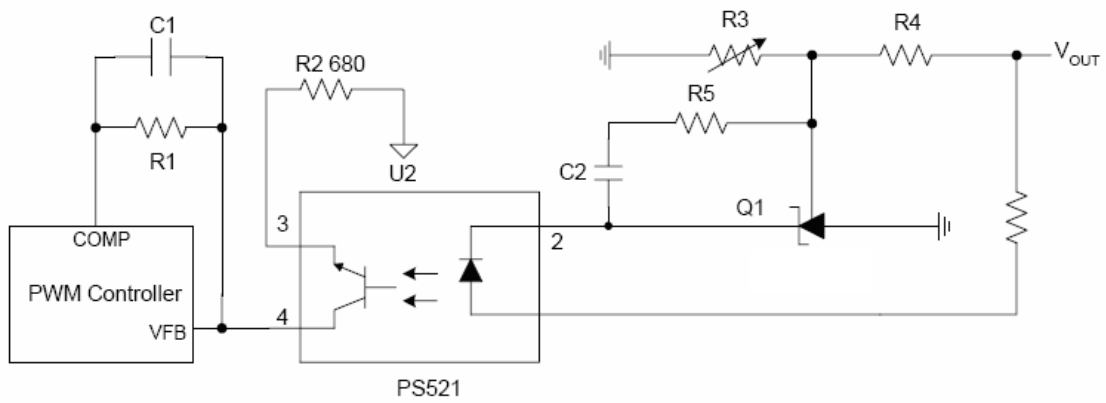
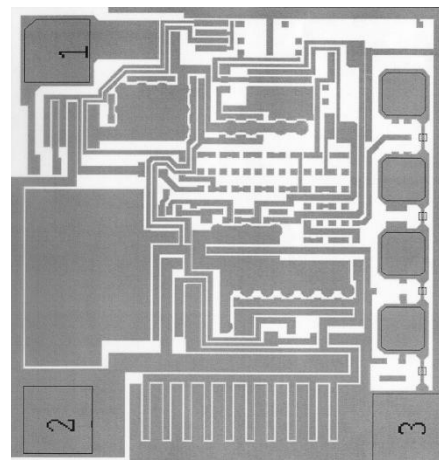
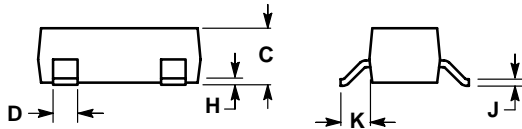
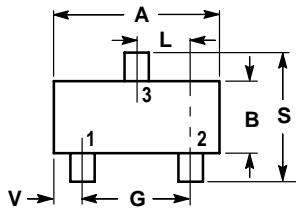

Figure 18: PWM Converter with Reference



 Chip Size(before saw) : 0.72 * 0.68 (mm)²

SOT-23
NOTES:

1. DIMENSIONING AND TOLERANCING PER ANSI Y14.5M,1982
2. CONTROLLING DIMENSION: INCH.

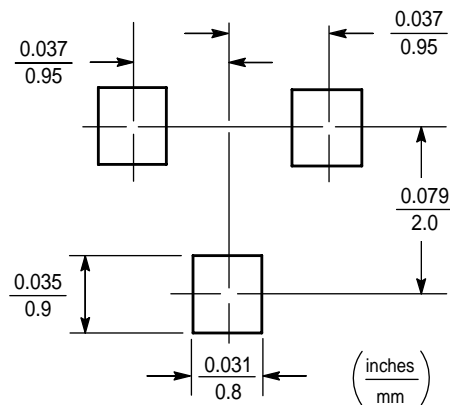

DIM	INCHES		MILLIMETERS	
	MIN	MAX	MIN	MAX
A	0.1102	0.1197	2.80	3.04
B	0.0472	0.0551	1.20	1.40
C	0.0350	0.0440	0.89	1.11
D	0.0150	0.0200	0.37	0.50
G	0.0701	0.0807	1.78	2.04
H	0.0005	0.0040	0.013	0.100
J	0.0034	0.0070	0.085	0.177
K	0.0140	0.0285	0.35	0.69
L	0.0350	0.0401	0.89	1.02
S	0.0830	0.1039	2.10	2.64
V	0.0177	0.0236	0.45	0.60



Tape & Reel and Packaging Specifications

Embossed Tape and Reel is used to facilitate automatic pick and place equipment feed requirements. The tape is used as the shipping container for various products and requires a minimum of handling. The antistatic/conductive tape provides a secure cavity for the product when sealed with the “peel-back” cover tape.

- Two Reel Sizes Available (7" and 13")
- Used for Automatic Pick and Place Feed Systems
- Minimizes Product Handling
- EIA 481, -1, -2
- SOT-23, SC-70/SOT-323,
- SC-89, SC-88/SOT-363, SC-88A/SOT-353,
- SOD-323, SOD-523 in 8 mm Tape

Use the standard device title and add the required suffix as listed in the option table below (Table 1). Note that the individual reels have a finite number of devices depending on the type of product contained in the tape. Also note the minimum lot size is one full reel for each line item, and orders are required to be in increments of the single reel quantity.

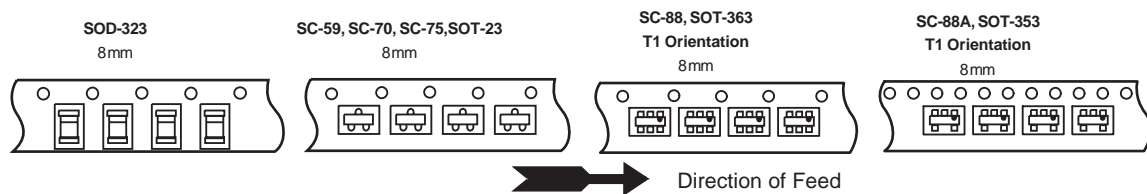

Typical Reel Orientations

Table 1. EMBOSSED TAPE AND REEL ORDERING INFORMATION

Package	Tape Width (mm)	Pitch mm	Reel Size mm(inch)	Devices Per Reel and Minimum Order Quantity	Device Suffix
SOT-23	8	4	178	(7)	3,000 T1
	8		330	(13)	10,000 T3
SC-70/SOT-323	8	4	178	(7)	3,000 T1
	8		330	(13)	10,000 T3
SC-89	8	4	178	(7)	3,000 T1
	8		330	(13)	10,000 T3
SC-88/SOT-363	8	4	178	(7)	3,000 T1
	8		330	(13)	10,000 T3
SC-88A/SOT-353	8	4	178	(7)	3,000 T1
	8		330	(13)	10,000 T3
SOD-323	8	4	178	(7)	3,000 T1
	8		330	(13)	10,000 T3
SOD-523	8	4	178	(7)	3,000 T1
	8		330	(13)	10,000 T3

EMBOSSED TAPE AND REEL DATA FOR DISCRETES CARRIER TAPE SPECIFICATIONS

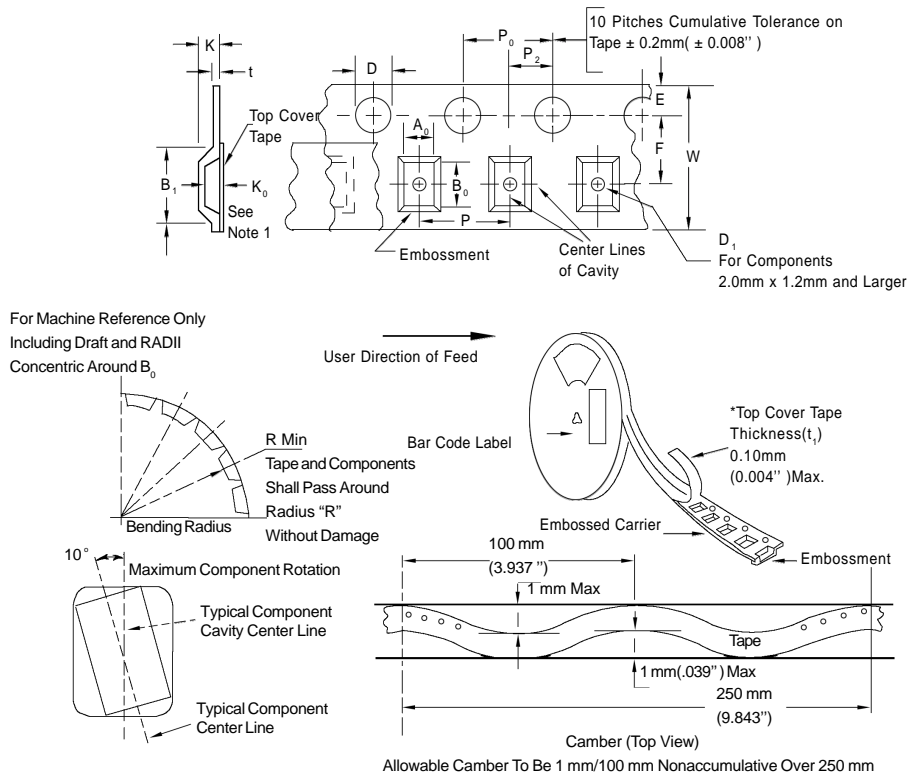

DIMENSIONS

Tape Size	B_1 Max	D	D_1	E	F	K	P_0	P_2	RMin	TMax	WMax
8mm	4.55mm (.179")	1.5±0.1mm - 0.0	1.0Min (.039")	1.75±0.1mm (.069±.004)	3.5±0.05mm (.138±.002")	2.4mmMax (.094")	4.0±0.1mm (.157±.004")	2.0±0.1mm (.079±.002")	25mm (.98")	0.6mm (.024")	8.3mm (.327")
12mm	8.2mm (.323")	(.059±.004") - 0.0	1.5mmMin (.060")		5.5±0.05mm (.217±.002")	6.4mmMax (.252")			30mm (1.18")		12±.30mm (.470±.012")
16mm	12.1mm (.476")				7.5±0.10mm (.295±.004")	7.9mmMax (.311")					16.3mm (.642")
24mm	20.1mm (.791")				11.5±0.1mm (.453±.004")	11.9mmMax (.468")					24.3mm (.957")

Metric dimensions govern - English are in parentheses for reference only.

NOTE 1: A_0 , B_0 , and K_0 are determined by component size. The clearance between the components and the cavity must be within .05 mm min. to .50 mm max.,

NOTE 2: the component cannot rotate more than 10° within the determined cavity.

NOTE 3: If B_1 exceeds 4.2 mm (.165") for 8 mm embossed tape, the tape may not feed through all tape feeders.

EMBOSSED TAPE AND REEL DATA FOR DISCRETES

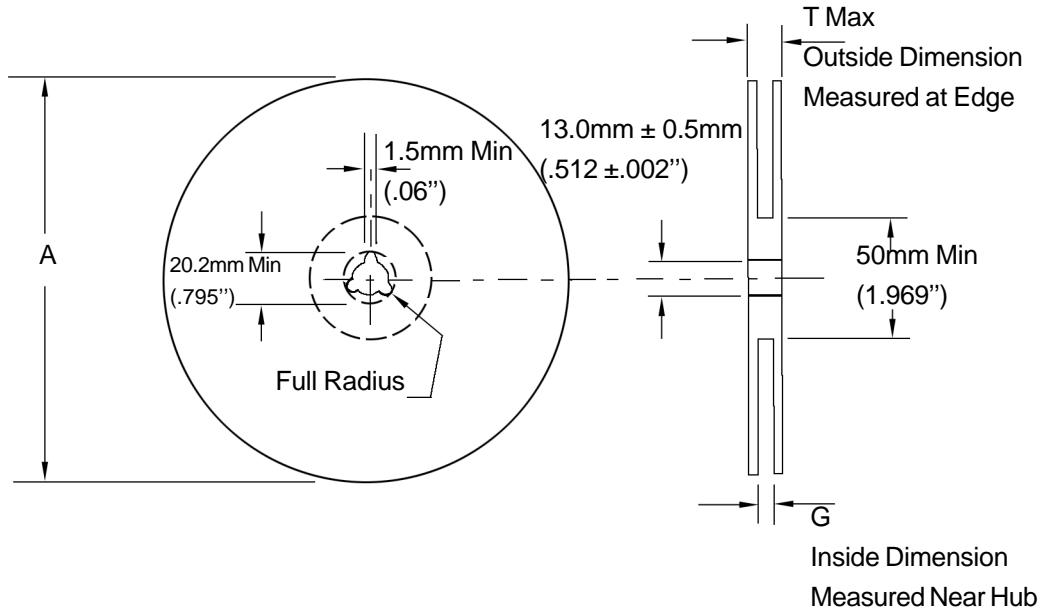

Size	A Max	G	T Max
8 mm	330mm (12.992")	8.4mm+1.5mm, -0.0 (.33"+.059", -0.00)	14.4mm (.56")
12mm	330mm (12.992")	12.4mm+2.0mm, -0.0 (.49"+.079", -0.00)	18.4mm (.72")
16mm	360mm (14.173")	16.4mm+2.0mm, -0.0 (.646"+.078", -0.00)	22.4mm (.882")
24 mm	360mm (14.173")	24.4mm+2.0mm, -0.0 (.961"+.070", -0.00)	30.4mm (1.197")

Reel Dimensions

Metric Dimensions Govern — English are in parentheses for reference only

Storage Conditions

Temperature: 5 to 40 Deg.C (20 to 30 Deg. C is preferred)

Humidity: 30 to 80 RH (40 to 60 is preferred)

Recommended Period: One year after manufacturing

(This recommended period is for the soldering condition only. The characteristics and reliabilities of the products are not restricted to this limitation)

X-ON Electronics

Largest Supplier of Electrical and Electronic Components

Click to view similar products for [Voltage References](#) category:

Click to view products by [Leshan](#) manufacturer:

Other Similar products are found below :

[5962-8686103XC](#) [REF01J/883](#) [SC431ILPRAG](#) [AP432AQG-7](#) [LM4040B25QFTA](#) [EL5226IR](#) [EL5326IR](#) [EL5326IRZ](#) [ISL21007DFB825Z](#)
[ISL21009BFB812Z](#) [ISL21009CFB812Z](#) [ISL60002BIH312](#) [TS3320AMR](#) [TS3325AMR](#) [TS3330AMR](#) [TS3333AMR](#) [X60003CIG3-41](#)
[X60003DIG3Z-41T1](#) [X60250V8I](#) [REF3025TB-GT3](#) [SC432BVSNT1G](#) [TL431CPG](#) [LM336Z-5.0](#) [MMTL432](#) [TL431A](#) [LR432ATLT1G](#)
[TL432](#) [TL431A](#) [TL431NSG-AE2-R](#) [TL432](#) [TL431](#) [TL431](#) [CD431A](#) [TL432](#) [LM285M3-2.5/TR](#) [TL432AIM3/TR](#) [LM431AIM3/TR](#)
[MC1403MM/TR](#) [TL431CM3/TR](#) [HT432ARTZ](#) [TL431Z-AST](#) [LTL431APKLT1G](#) [TL4050B25QDBZR](#) [TL431ACZ](#) [KA431SLMF2TF](#)
[KA431SMF2TF](#) [KA431SMFTF](#) [LM4041C12ILPR](#) [LM4050AIM3X-5.0/NOPB](#) [LM4120AIM5-2.5/NOP](#)