

PROGRAMMABLE PRECISION REFERENCE

LR432XXTLT1G

Description

The LR432XXTLT1G is a three-terminal adjustable regulator with a guaranteed thermal stability over applicable temperature ranges. The output voltage may be set to any value between V_{REF} (approximately 1.24V) and 18V with two external resistors. It provides very wide applications, including shunt regulator, series regulator, switching regulator, voltage reference and others.

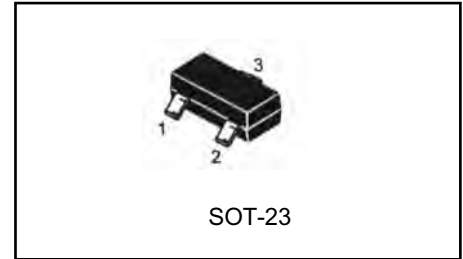

SOT-23 1: Ref; 2: Cathode; 3: Anode

Features:

- Precise Reference Voltage to 1.24V
- Guaranteed 0.5% Reference Voltage Tolerance
- Sink Current Capability, 55 μ A to 100mA
- Quick Turn-on
- Adjustable Output Voltage, $V_o = V_{REF}$ to 18V
- 0.05 Ω Typical Output Impedance
- We declare that the material of product is ROHS compliant and does not contain any Br, Cl, and Sb203
- ESD HBM 7000V

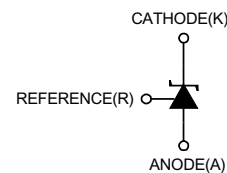
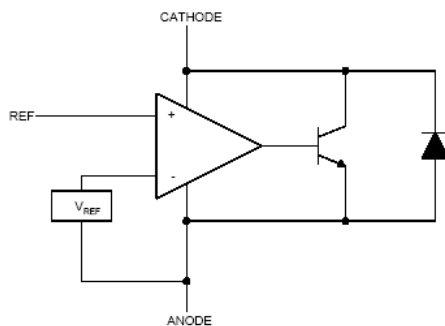

Absolute Maximum Ratings

Symbol	Parameter	Rating	Unit
V_{KA}	Cathode voltage	20	V
I_K	Continuous cathode current range	100	mA
I_{REF}	Reference current range	10	mA
T_j	Operating Junction Temperature Range	150	°C
T_{opr}	Operating Ambient Temperature	- 40 to 125	°C

Electrical Characteristics

 (Typical and limits apply for $T_j=25^\circ\text{C}$ unless otherwise noted.)

Characteristic		Test Circuit	Symbol	Test conditions	MIN	TYP	MAX	UNIT
Reference Voltage	0.5%	3	V_{REF}	$V_{KA}=V_{REF}, I_{KA}=10\text{mA}$	1.234	1.240	1.246	V
	1%				1.228	1.240	1.252	
Deviation of Reference Voltage Over-Temperature		3	ΔV_{REF}	$V_{KA}=V_{REF}$ $I_{KA}=10\text{mA}$	0 to 70°C	2	10	mV
					-20 to 125°C	3	15	
					-40 to 125°C	8	25	
Ratio of Change in VREF to the Change in Cathode Voltage		4	$\Delta V_{REF}/\Delta V_{KA}$	$\Delta V_{KA}: V_{REF}$ to 16V		-0.5	-1.5	mV/V
Reference Input Current		4	I_{REF}	$I_{KA}=10\text{mA}, R1=10\text{K}\Omega, R2=\infty$		0.15	0.4	μA
Deviation of Reference Current Over Full Temperature Range		4	ΔI_{REF}	$I_{KA}=10\text{mA}, R1=10\text{K}\Omega, R2=\infty$ $T_A=-20$ to 85°C		0.1	0.4	μA
Minimum Cathode Current for Regulation		3	$I_{KA(MIN)}$	$V_{KA}=V_{REF}$		55	80	μA
Off-State Cathode Current		5	$I_{KA(OFF)}$	$V_{REF}=0, V_{KA}=18\text{V}$		0.04	0.50	μA
				$V_{KA}=6\text{V}, V_{REF}=0$		0.01	0.05	
Dynamic Impedance		3	Z_{KA}	$V_{KA}=V_{REF}, I_{KA}=1$ to 100mA $f \leq 1.0\text{kHz}$		0.05	0.15	Ω

Classification of Vref and package

Device	Marking	RanK	Vref(V)
LR432ATLT1G	9D	1.0%	1.24
LR432BTLT1G	9E	0.5%	1.24
LR432APTLT1G		1.0%	1.25
LR432BPTLT1G		0.5%	1.25

Package: SOT23

TEST CIRCUIT

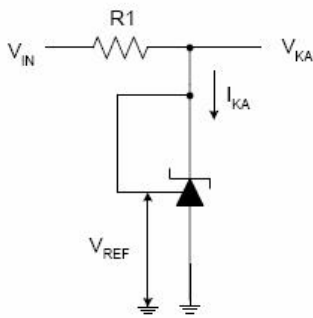

Figure 3 Test Circuit 3 for $V_{KA}=V_{REF}$

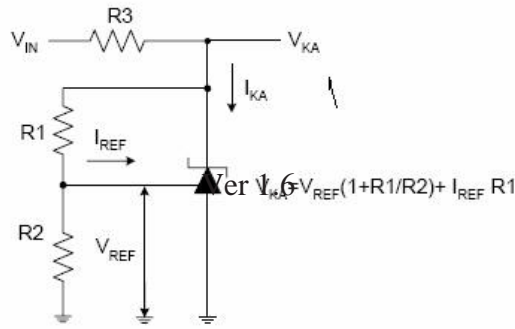

Figure 4. Test Circuit 4 for $V_{KA}>V_{REF}$

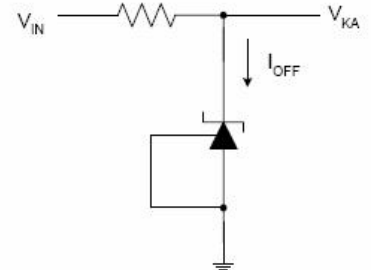

Figure 5. Test Circuit 5 for I_{OFF}

TYPICAL PERFORMANCE CHARACTERISTICS

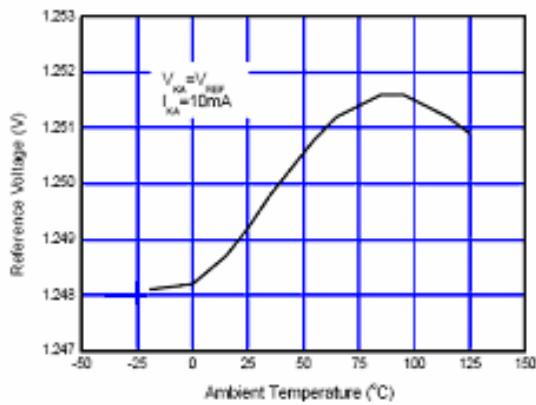

Figure 6. Reference Voltage vs. Ambient Temperature

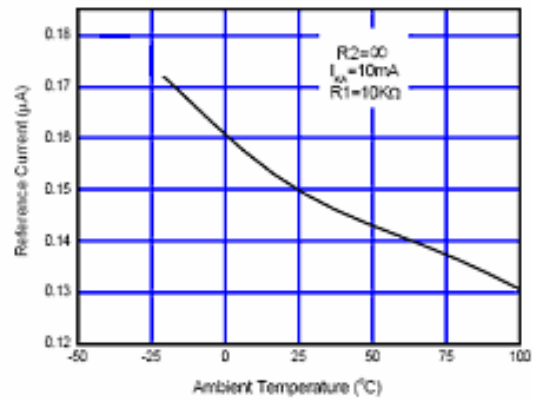

Figure 7. Reference Current vs. Ambient Temperature

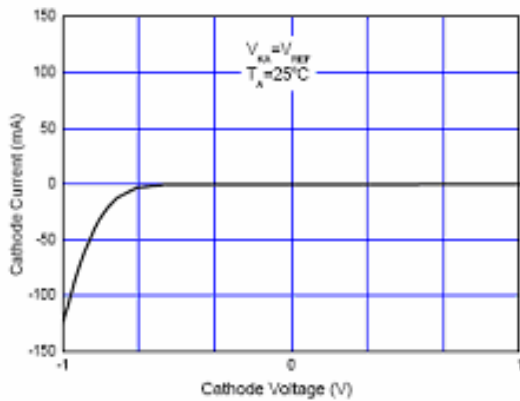

Figure 8. Cathode Current vs. Cathode Voltage

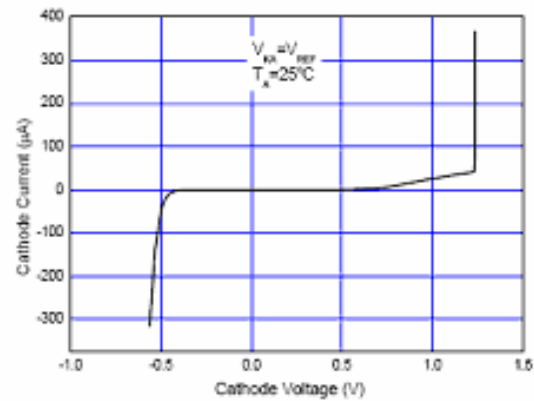

Figure 9. . Current vs. cathode Voltage

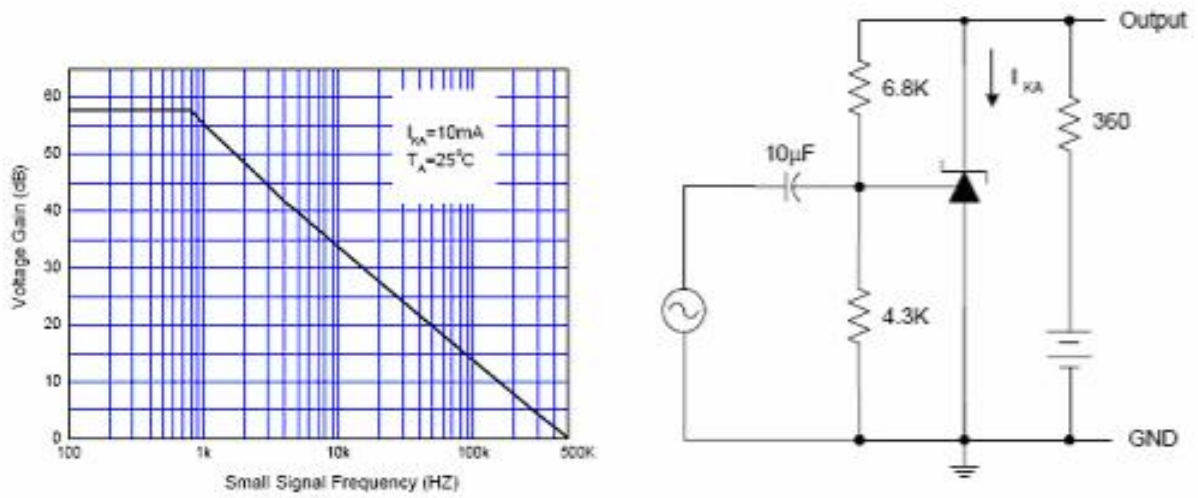

Figure 10. Small Signal Voltage Gain vs. Frequency

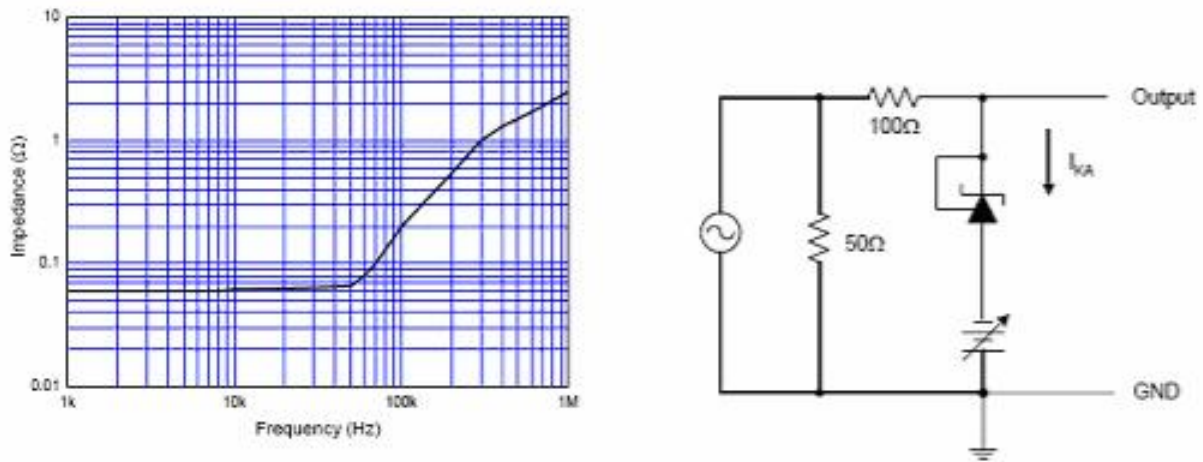

Figure 11. Dynamic Impedance vs. Frequency

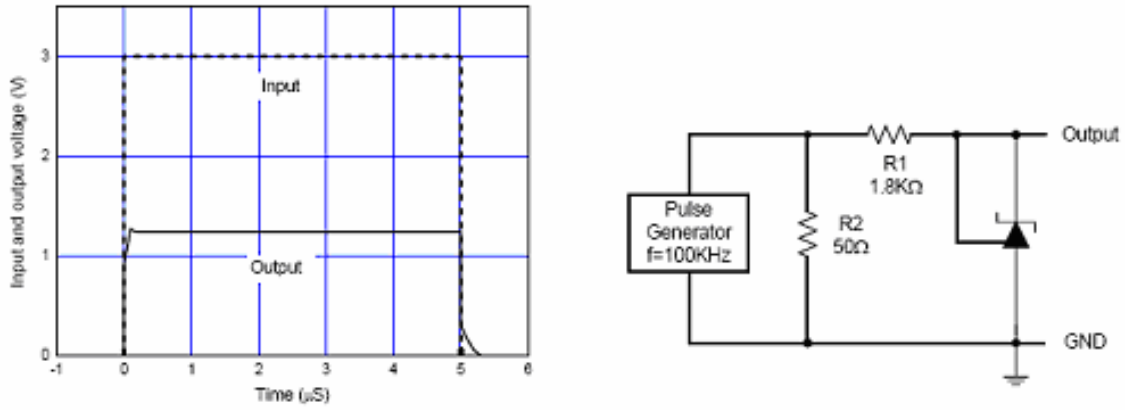

Figure 12. Pulse Response of Input and Output Voltage

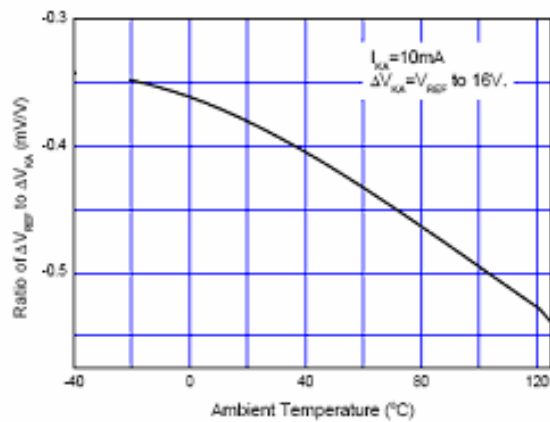

Figure 13. Ratio of Delta Reference Voltage to the Ratio of Delta Cathode Voltage vs. Ambient Temperature

TYPICAL APPLICATIONS

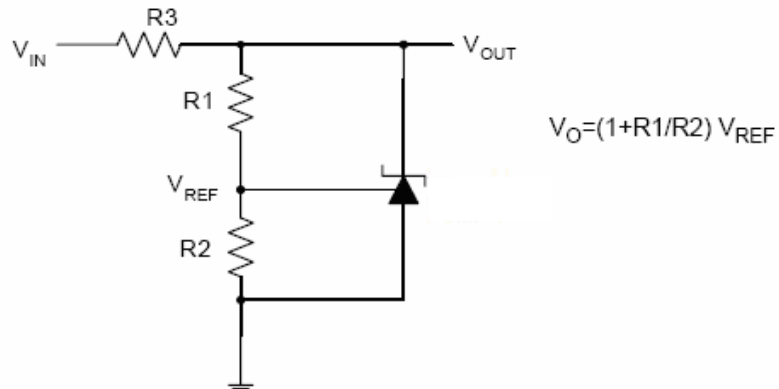

Figure 14: Shunt Regulator

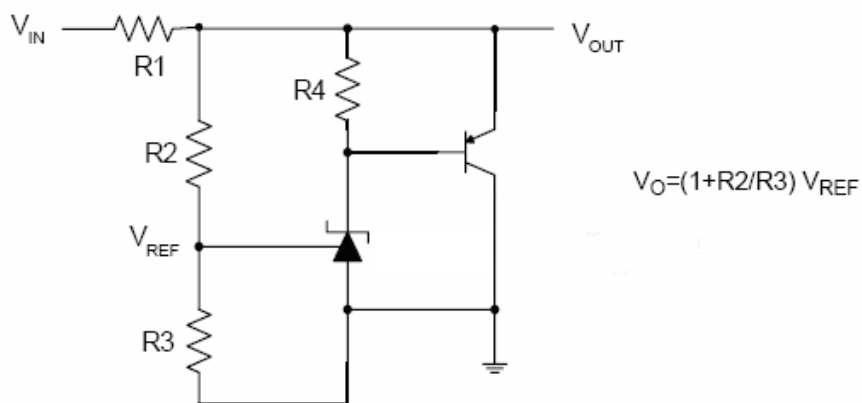

Figure 15 High Current Shunt Regulator

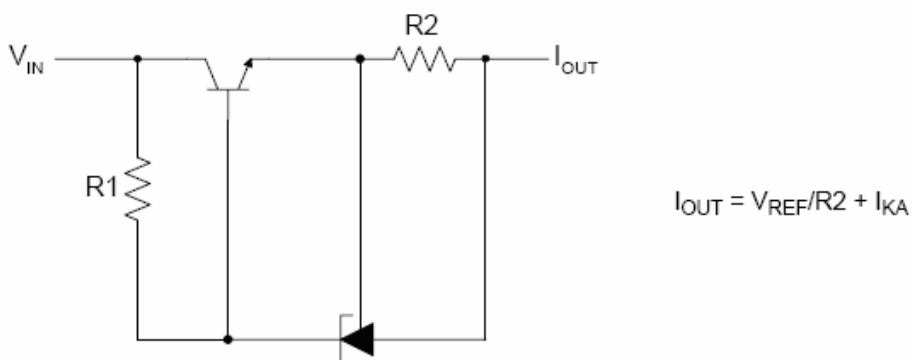

Figure 16: Current Source or Current Limit

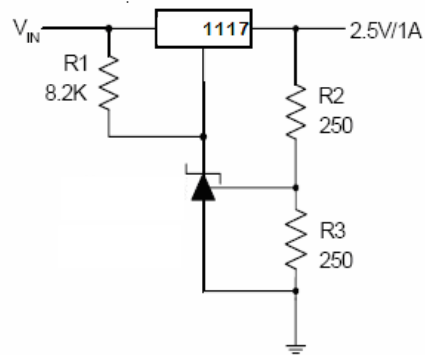

Figure 17 Precision 2.5V/1A Regulator

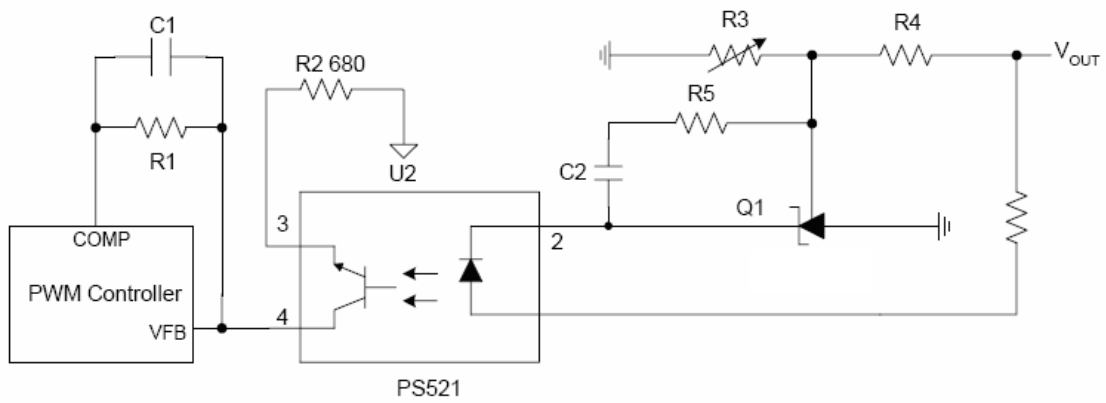
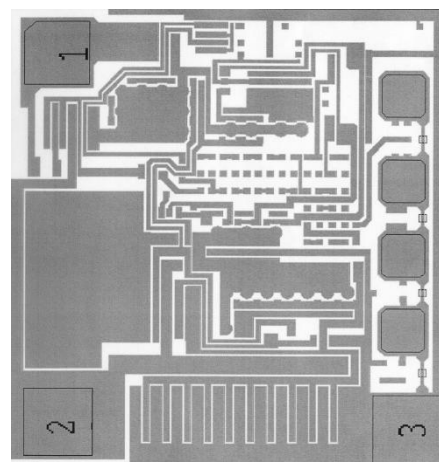
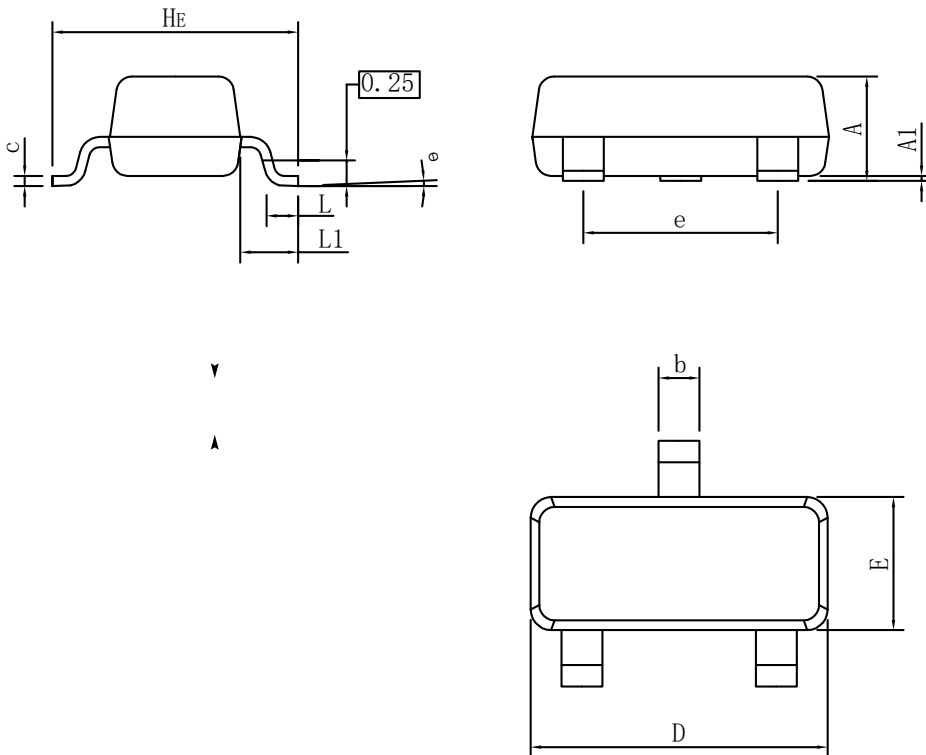

Figure 18: PWM Converter with Reference

 Chip Size(before saw) : 0.72 * 0.68 (mm)²

SOT-23 PACKAGE OUTLINE DIMENSIONS

SOT23			
DIM	MIN	NOR	MAX
A	0.90	1.00	1.10
A1	0.01	0.06	0.10
b	0.30	0.40	0.50
c	0.10	0.17	0.20
D	2.80	2.90	3.00
E	1.20	1.30	1.40
e	1.80	1.90	2.00
L	0.20	0.40	0.60
L1	0.60REF		
HE	2.20	2.40	2.60
θ	0°	-	10°
All Dimensions in mm			

GENERAL NOTES

1. Top package surface finish Ra0.4±0.2um
2. Bottom package surface finish Ra0.7±0.2um
3. Side package surface finish Ra0.4±0.2um

X-ON Electronics

Largest Supplier of Electrical and Electronic Components

Click to view similar products for [Microprocessors - MPU category](#):

Click to view products by [Leshan manufacturer](#):

Other Similar products are found below :

[MC68302EH20C](#) [MC7457RX1000LC](#) [MC7457RX1267LC](#) [MC7457VG1267LC](#) [A2C00010998 A](#) [A2C52004004](#) [R5F117BCGNA#20](#)
[R5F52106BDLA#U0](#) [R5S72690W266BG#U0](#) [ADJ3400IAA5DOE](#) [MPC8245TVV266D](#) [MPC8245TZU300D](#) [MPC8260ACVVMHBB](#)
[MPC8323ECVRAFDCA](#) [MPC8536ECVJAVLA](#) [BOXNUC5PGYH0AJ](#) [20-668-0024](#) [P1010NSN5DFB](#) [P2010NSN2MHC](#) [P2020NXE2HHC](#)
[P5020NSE7QMB](#) [P5020NSE7TNB](#) [P5020NSE7VNB](#) [LS1020ASN7KQB](#) [LS1020AXN7HNB](#) [LS1020AXN7KQB](#) [A2C00010729 A](#)
[A2C00039344](#) [T1022NSE7MQB](#) [T1022NXN7PQB](#) [T1023NSE7MQA](#) [T1024NXE7PQA](#) [T1042NSE7MQB](#) [T1042NSN7MQB](#)
[T1042NXN7WQB](#) [T2080NSE8TTB](#) [T2080NSN8PTB](#) [T2080NXE8TTB](#) [T2081NXN8TTB](#) [R5F101AFASP#V0](#) [MC68302CEH20C](#)
[TS68040MF33A](#) [MPC8260ACVVMIBB](#) [MPC8280CZUPEA](#) [MPC8313ECVRAFFC](#) [MPC8313ECVRAGDC](#) [MPC8313EVRADDC](#)
[MPC8313EVRAFFC](#) [MPC8313VRADDC](#) [MPC8314CVRAGDA](#)