

Ultra Fast High PSRR

Low Noise CMOS Voltage Regulator

LR6205 Series

■ **INTRODUCTION**

The LR6205 series are a group of positive voltage regulators manufactured by CMOS technologies with high ripple rejection, ultra low noise, low power consumption and low dropout voltage, which can prolong battery life in portable electronics. The LR6205 series work with low-ESR ceramic capacitors, reducing the amount of board space necessary for power applications. The LR6205 series consume less than 0.1uA in shutdown mode and have fast turn-on time less than 50us. The series are very suitable for the battery-powered equipments, such as RF applications and other systems requiring a quiet voltage source.

■ **APPLICATIONS**

- Cellular and Smart Phones
- Laptop, Palmtops and PDA
- Digital Still and Video Cameras

■ **FEATURES**

- Low Output Noise: $40\mu V_{RMS}$ (10Hz~100kHz)
- Low Dropout Voltage: $150mV@150mA$
- Low Quiescent Current: $50\mu A$
- High Ripple Rejection: $80dB@217Hz$
- Excellent Line and Load Transient Response
- Operating Voltage: $2.0V\sim 6.0V$
- Output Voltage: $1.2\sim 5.0V$
- High Accuracy: $\pm 2\%$ (Typ.)
- Built-in Current Limiter, Short-Circuit Protection
- TTL- Logic-Controlled Shutdown Input

- MP3, MP4 Player
- Radio control systems
- Battery-Powered Equipment

■ **BLOCK DIAGRAM**

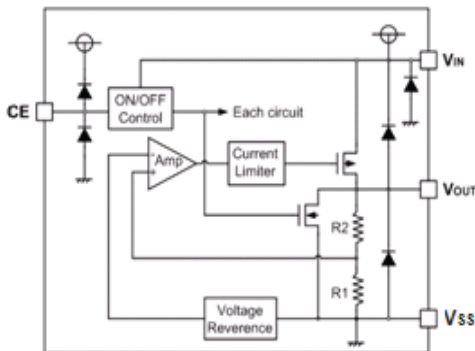

■ **ORDER INFORMATION**

LR6205①②③④

DESIGNATOR	SYMBOL	DESCRIPTION
①	A	Without EN
	B	High Active, pull-down resistor built in, with C _{OUT} discharge resistor
	C	High Active, No pull-down resistor, No C _{OUT} discharge resistor
②③	Integer	Output Voltage e.g.1.8V=②:1, ③:8
④	M/MA/MC/MY	Package:SOT-23-3
	M/MF/ML	Package:SOT-23-5
	P/PT	Package:SOT-89-3
	F	Package:DFN1X1-4

■ PIN CONFIGURATION

SOT-23-3

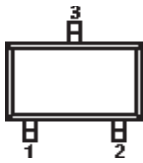

SOT-23-5

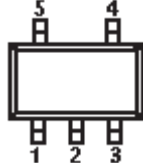

DFN1X1-4

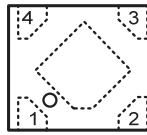

SOT-89-3

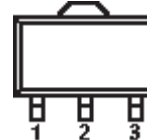

PIN NUMBER						PIN NAME	FUNCTION
SOT-23-3			SOT-89-3				
M	MA	MC	MY	P	PT		
1	2	3	3	1	2	V_{SS}	Ground
2	1	2	1	3	1	V_{OUT}	Output
3	3	1	2	2	3	V_{IN}	Power input

SOT-23-5

PIN NUMBER			SYMBOL	FUNCTION
M	MF	ML		
1	1	5	V_{IN}	Power Input Pin
2	2	2	V_{SS}	Ground
3	—	1	CE	Chip Enable Pin
4	3/4	3	NC	No Connection
5	5	4	V_{OUT}	Output Pin

DFN1×1-4

PIN NUMBER		SYMBOL	FUNCTION
F			
1		V_{OUT}	Output Pin
2		V_{SS}	Ground
3		CE	Chip Enable Pin
4		V_{IN}	Power Input Pin

■ TYPICAL APPLICATION

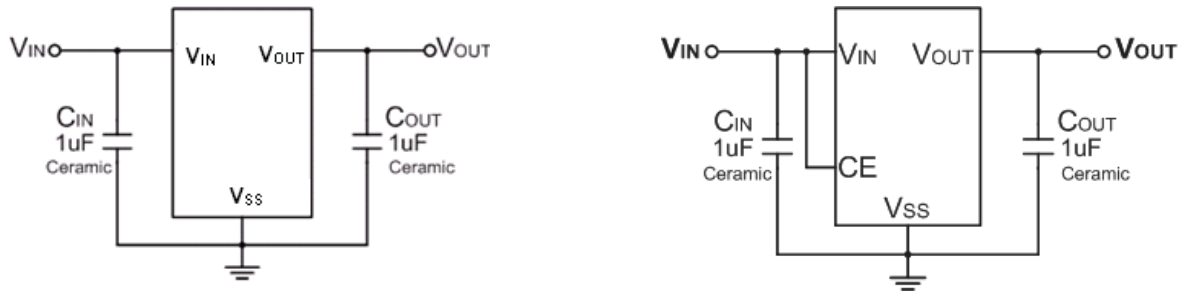

■ ABSOLUTE MAXIMUM RATINGS

(Unless otherwise specified, Ta=25°C)

PARAMETER	SYMBOL	RATINGS	UNITS
Input Voltage	V _{IN}	V _{SS} -0.3~V _{SS} +7	V
Output Current	I _{OUT}	600	mA
Output Voltage	V _{OUT}	V _{SS} -0.3~V _{IN} +0.3	V
Power Dissipation	SOT-23	Pd	370
	SOT-89	Pd	500
	DFN1x1-4	Pd	400
Operating Temperature	T _{opr}	-40~+85	°C
Storage Temperature	T _{stg}	-40~+125	°C
Soldering Temperature & Time	T _{solder}	260°C, 10s	

■ ELECTRICAL CHARACTERISTICS

 L6205 Series (V_{IN}=V_{OUT}+1V, C_{IN}=C_{OUT}=1μF, Ta=25°C, unless otherwise specified)

PARAMETER	SYMBOL	CONDITIONS	MIN.	TYP.	MAX.	UNITS
Output Voltage	V _{OUT(E)} ⁽²⁾	I _{OUT} =1mA	V _{OUT} *0.98	V _{OUT}	V _{OUT} *1.02	V
Supply Current	I _{SS}	I _{OUT} =0		50	100	μA
Standby Current	I _{STBY}	CE = V _{SS}			0.1	μA
Output Current	I _{OUT}	—	500			mA
Dropout Voltage ⁽³⁾	V _{dif}	I _{OUT} =150mA V _{OUT} ≥2.8V		150		mV
Load Regulation	ΔV _{OUT}	V _{IN} = V _{OUT} +1V, 1mA≤I _{OUT} ≤100mA		10		mV
Line Regulation	$\frac{\Delta V_{OUT}}{V_{OUT} \times \Delta V_{IN}}$	I _{OUT} =10mA V _{OUT} +1V≤V _{IN} ≤6V		0.01	0.2	%/V
Output Voltage Temperature Characteristics	$\frac{\Delta V_{OUT}}{\Delta T \times V_{OUT}}$	I _{OUT} =10mA -40≤T≤+85		100		ppm
Short Current	I _{Short}	V _{OUT} =V _{SS}		100		mA
Input Voltage	V _{IN}	—	2.0		6.0	V

■ ELECTRICAL CHARACTERISTICS

LR6205 Series ($V_{IN}=V_{OUT}+1V$, $C_{IN}=C_{OUT}=1\mu F$, $T_a=25^\circ C$, unless otherwise specified)

PARAMETER	SYMBOL	CONDITIONS	MIN.	TYP.	MAX.	UNITS
Power Supply Rejection Rate	217Hz	$I_{OUT}=50mA$		80		dB
	1kHz			75		
	10kHz			70		
CE "High" Voltage	$V_{CE} "H"$		1.5		V_{IN}	V
CE "Low" Voltage	$V_{CE} "L"$				0.3	V

NOTE:

- V_{OUT} : Specified Output Voltage.
- $V_{OUT} (E)$: Effective Output Voltage (i.e. The Output Voltage When $V_{IN} = (V_{OUT} + 1.0V)$ And Maintain A Certain I_{OUT} Value).
- V_{dif} : The Difference Of Output Voltage And Input Voltage When Input Voltage Is Decreased Gradually Till Output Voltage Equals To 98% Of $V_{OUT} (E)$.

■ DROPOUT VOLTAGE CHART

Setting Output Voltage	Dropout Voltage(mV)@ $I_{OUT}=150mA$	
$V_{OUT}(V)$	Typ.	Max.
1.2	380	600
1.5	270	600
1.8	230	600
2.5	180	400
2.8	160	220
3.0	155	220
3.3	150	220

■ TYPICAL PERFORMANCE CHARACTERISTICS

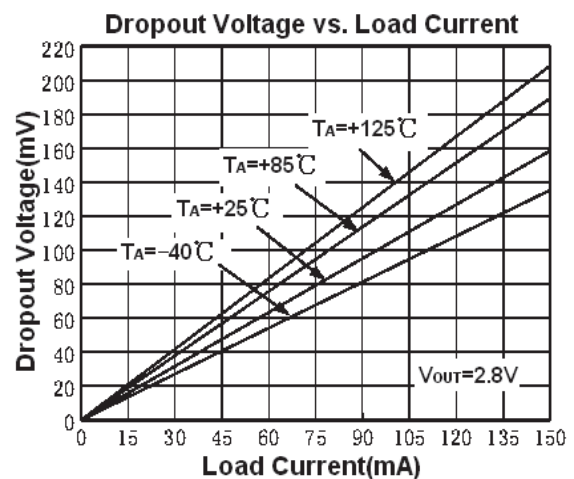
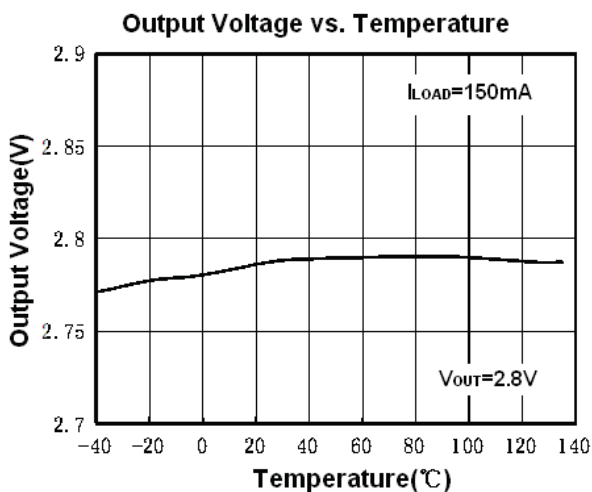

■ TYPICAL PERFORMANCE CHARACTERISTICS

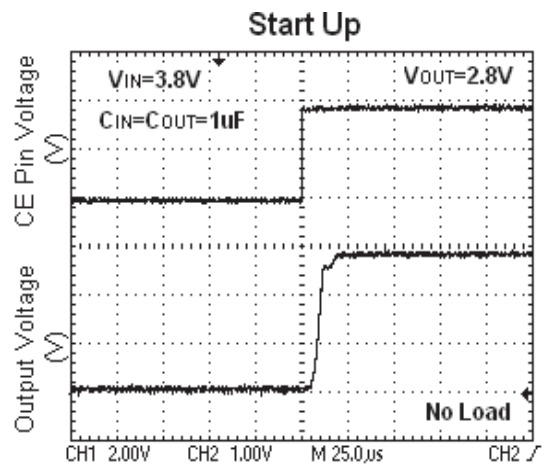
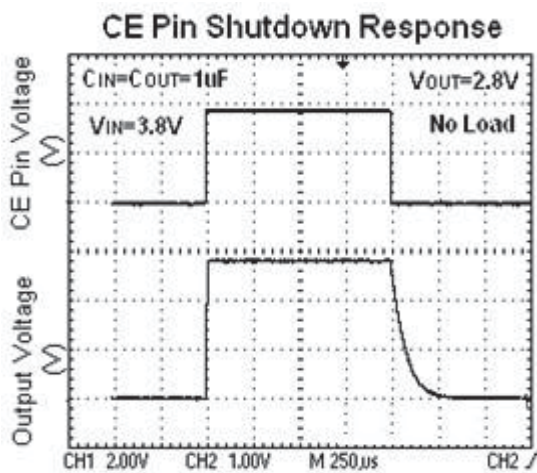
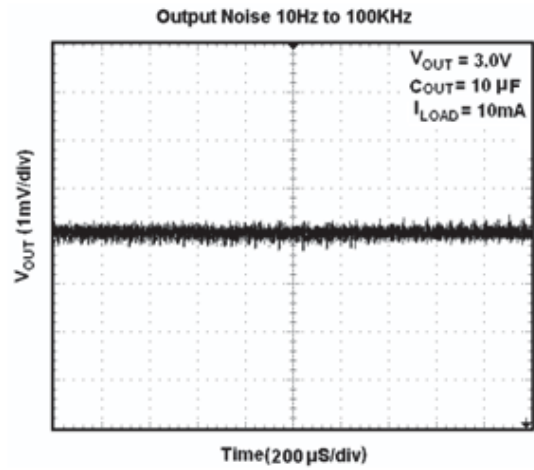
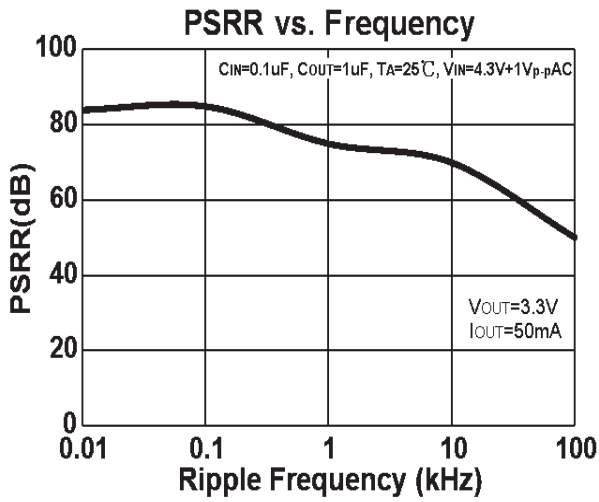
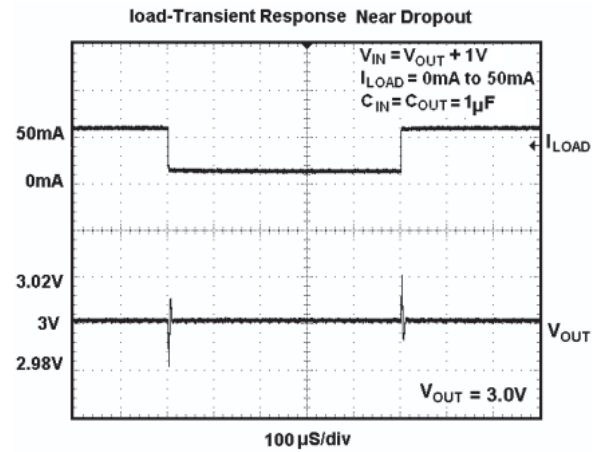
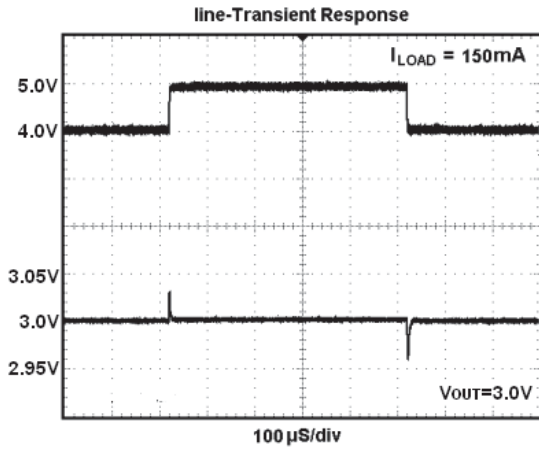

■ PACKAGING INFORMATION

● SOT-23-3 PACKAGE OUTLINE DIMENSIONS

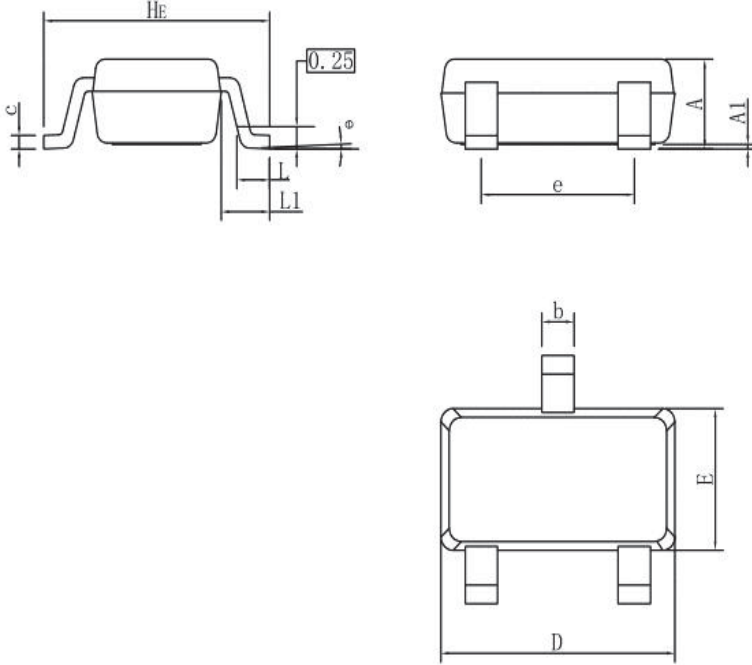

DIM	MIN	NOR	MAX
A	0.90	1.00	1.10
A1	0.01	0.06	0.10
b	0.30	0.40	0.50
c	0.10	0.17	0.20
D	2.80	2.90	3.00
E	1.50	1.60	1.70
e	1.80	1.90	2.00
L	0.20	0.40	0.60
L1	0.60REF		
HE	2.60	2.80	3.00
θ	0°	-	10°
All Dimensions in mm			

GENERAL NOTES

- 1.Top package surface finish Ra0.4±0.2um
- 2.Bottom package surface finish Ra0.7±0.2um
- 3.Side package surface finish Ra0.4±0.2um

SOLDERING FOOTPRINT

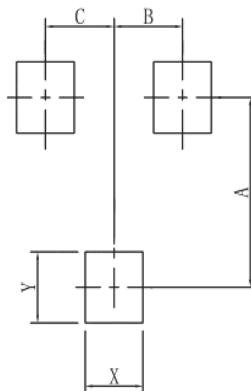

DIM	(mm)
X	0.80
Y	0.90
A	2.40
B	0.95
C	0.95

• SOT-23-5 PACKAGE OUTLINE DIMENSIONS

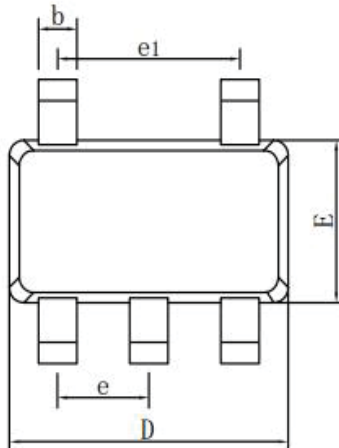
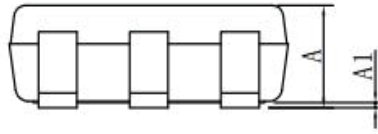
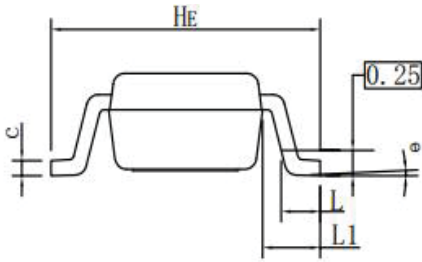

DIM	MIN	NOR	MAX
A	0.90	1.00	1.10
A1	0.01	0.06	0.10
b	0.30	0.40	0.50
c	0.10	0.17	0.20
D	2.80	2.90	3.00
E	1.50	1.60	1.70
e	0.85	0.95	1.05
e1	1.80	1.90	2.00
L	0.20	0.40	0.60
L1	0.60REF		
HE	2.60	2.80	3.00
θ	0°	-	10°

GENERAL NOTES

- 1.Top package surface finish Ra0.4±0.2um
- 2.Bottom package surface finish Ra0.7±0.2um
- 3.Side package surface finish Ra0.4±0.2um

SOLDERING FOOTPRINT

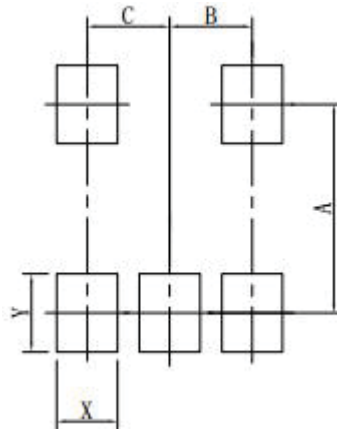

DIM	(mm)
X	0.70
Y	0.90
A	2.40
B	0.95
C	0.95

● SOT-89-3 PACKAGE OUTLINE DIMENSIONS

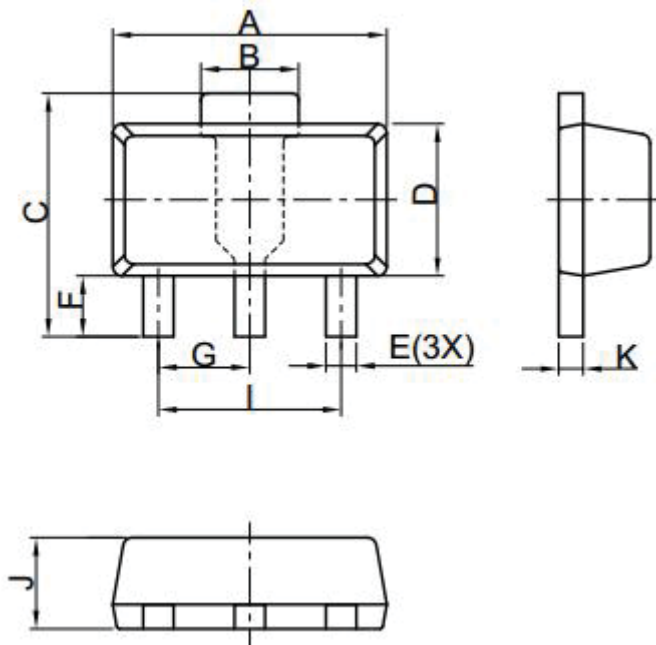

DIM	MIN	NOR	MAX
A	4.40	4.50	4.60
B	1.40	1.60	1.80
C	3.90	4.00	4.25
D	2.40	2.50	2.60
E	0.40	0.50	0.58
F	0.90	1.00	1.20
G	1.50 BSC		
I	3.00 BSC		
J	1.40	1.50	1.60
K	0.34	0.40	0.50
All Dimensions in mm			

GENERAL NOTES

1. Top package surface finish Ra0.4±0.2um
2. Bottom package surface finish Ra0.7±0.2um
3. Side package surface finish Ra0.4±0.2um
4. Protrusion or Gate Burrs shall not exceed 0.10mm per side.

SOLDERING FOOTPRINT

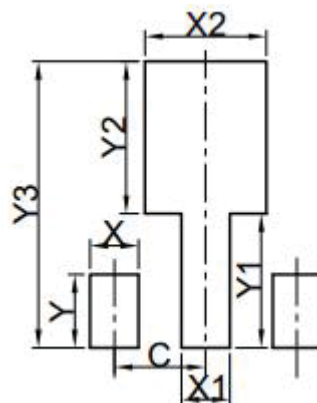

DIM	(mm)
X	0.80
Y	1.20
X1	0.80
Y1	2.20
X2	2.00
Y2	2.50
C	1.50
Y3	4.70

● DFN1X1-4 PACKAGE OUTLINE DIMENSIONS

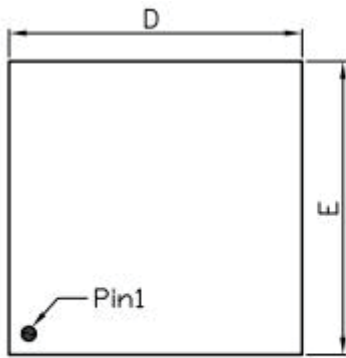

TOP VIEW

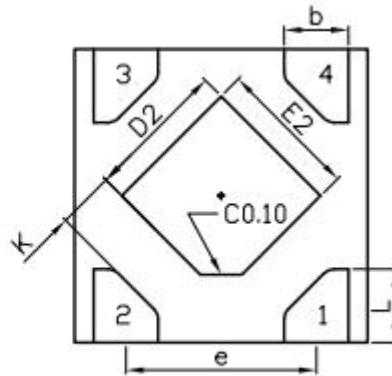

BOTTOM VIEW

DFN1010			
DIM	MIN	NOR	MAX
A	0.34	0.37	0.40
A1	0.01	0.02	0.05
b	0.17	0.22	0.25
L	0.20	0.25	0.30
D	0.95	1.00	1.05
E	0.95	1.00	1.05
D2	0.43	0.48	0.53
E2	0.43	0.48	0.53
e	0.65		
A3	0.127REF.		
K	0.15	-	-
All Dimensions in mm			

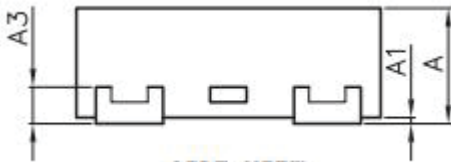

SIDE VIEW

SOLDERING FOOTPRINT

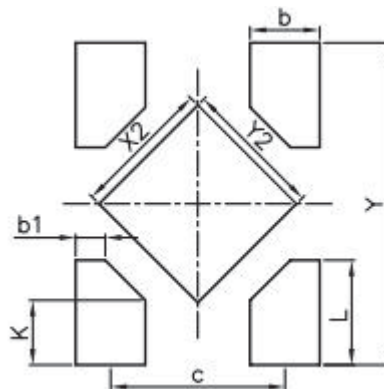

DFN1010	
DIM	(mm)
X2	0.52
Y2	0.52
L	0.39
Y	1.20
K	0.24
b	0.26
c	0.65
b1	0.11

■ ORDER INFORMATION APPENDIX

Device ⁽⁴⁾	Output Voltage ⁽⁵⁾	Package	Marking ⁽⁶⁾⁽⁷⁾	Shipping
LR6205AxxM	1.2V~5.0V	SOT-23-3	5AX	3K/Reel
LR6205AxxMA	1.2V~5.0V	SOT-23-3	5MX	3K/Reel
LR6205AxxMC	1.2V~5.0V	SOT-23-3	5CX	3K/Reel
LR6205AxxMY	1.2V~5.0V	SOT-23-3	5YX	3K/Reel
LR6205AxxMF	1.2V~5.0V	SOT-23-5	5FX	3K/Reel
LR6205BxxM	1.2V~5.0V	SOT-23-5	5BX	3K/Reel
LR6205BxxML	1.2V~5.0V	SOT-23-5	5LX	3K/Reel
LR6205AxxP	1.2V~5.0V	SOT89-3	5DX	1K/Reel
LR6205AxxPT	1.2V~5.0V	SOT89-3	5TX	1K/Reel
LR6205BxxF	1.2V~5.0V	DFN1X1-4	FX	10K/Reel

(4) : "xx" represents output voltage, eg "18" express that the output voltage is 1.8V

(5) : Output voltage varies from 1.2V to 5.0V, 0.1V an interval

(6) : The last letter "X" changes along with the output voltage, as figure below

(7) : There are additional marking, which relates to the date code

Voltage	1.0	1.2	1.5	1.8	2.5	2.7	2.8	3.0	3.3	3.6	4.0	4.2	5.0
Symble	D	E	F	G	H	I	J	K	L	M	N	T	P

■ TAPE AND REEL INFORMATION

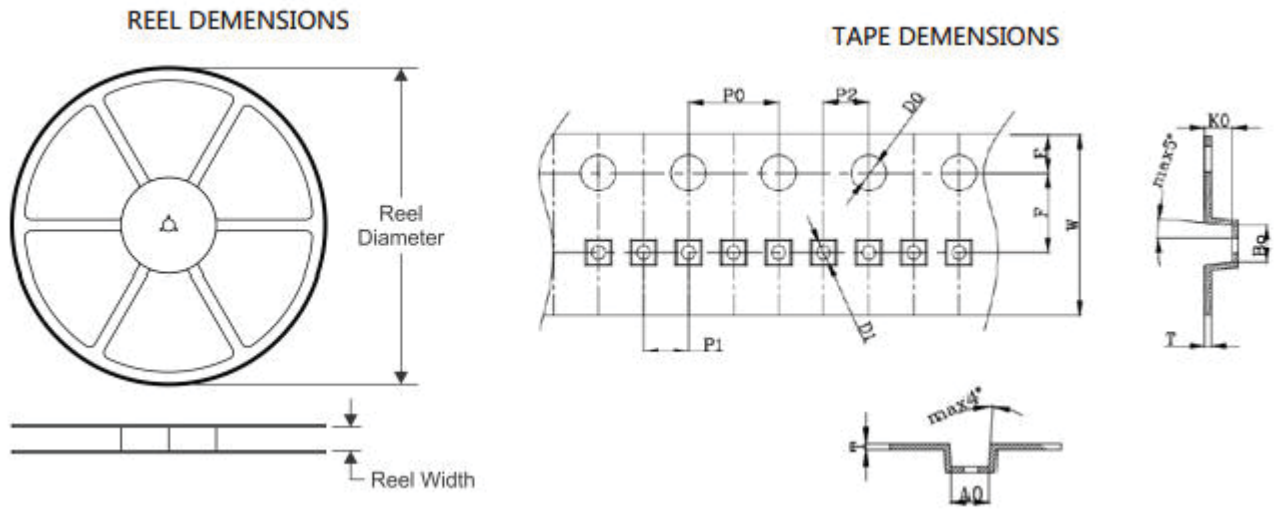

PIN ORIENTATION

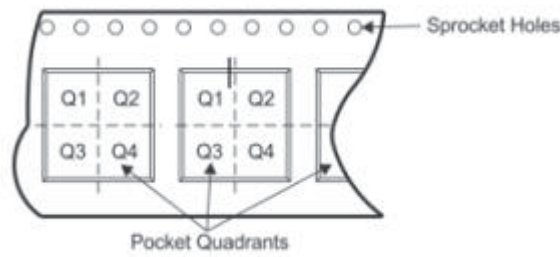

ROLLING ORIENTATION

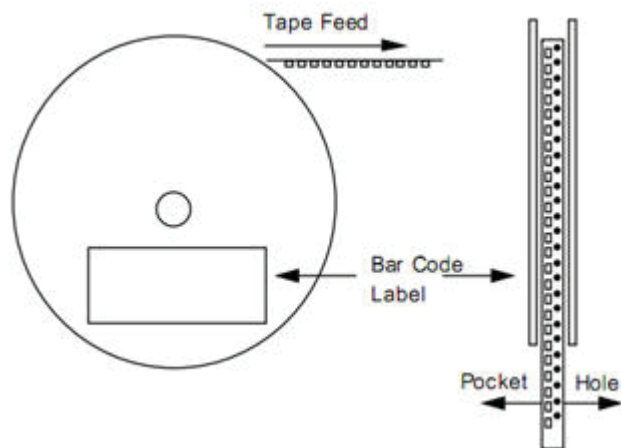

Device	Package	Reel Diameter (mm)	Reel width (mm)	P0 (mm)	P1 (mm)	A0 (mm)	B0 (mm)	K0 (mm)	W (mm)
LR6205AxxM	SOT-23-3	178±1	9.6±1.2	4.00±0.1	4.00±0.1	3.1±0.1	3.28±0.1	1.32±0.1	8.0±0.1
LR6205AxxMA	SOT-23-3	178±1	9.6±1.2	4.00±0.1	4.00±0.1	3.1±0.1	3.28±0.1	1.32±0.1	8.0±0.1
LR6205AxxMC	SOT-23-3	178±1	9.6±1.2	4.00±0.1	4.00±0.1	3.1±0.1	3.28±0.1	1.32±0.1	8.0±0.1
LR6205AxxMY	SOT-23-3	178±1	9.6±1.2	4.00±0.1	4.00±0.1	3.1±0.1	3.28±0.1	1.32±0.1	8.0±0.1
LR6205BxxM	SOT-23-5	178±1	9.6±1.2	4.00±0.1	4.00±0.1	3.25±0.05	3.15±0.05	1.5±0.05	8.0±0.1
LR6205BxxML	SOT-23-5	178±1	9.6±1.2	4.00±0.1	4.00±0.1	3.25±0.05	3.15±0.05	1.5±0.05	8.0±0.1
LR6205AxxMF	SOT-23-5	178±1	9.6±1.2	4.00±0.1	4.00±0.1	3.25±0.05	3.15±0.05	1.5±0.05	8.0±0.1
LR6205AxxP	SOT-89-3	178±1	13.0 ⁺¹ _{-0.5}	4.00±0.1	8.00±0.1	4.75±0.1	4.2±0.1	1.75±0.1	12.0 ^{+0.3} _{-0.1}
LR6205AxxPT	SOT-89-3	178±1	13.0 ⁺¹ _{-0.5}	4.00±0.1	8.00±0.1	4.75±0.1	4.2±0.1	1.75±0.1	12.0 ^{+0.3} _{-0.1}
LR6205BxxF	DFN1X1-4	178±1	9.6±1.2	4.00±0.1	2.00±0.05	1.16±0.05	1.16±0.05	0.5±0.05	8.0±0.1

X-ON Electronics

Largest Supplier of Electrical and Electronic Components

Click to view similar products for [Linear Voltage Regulators](#) category:

Click to view products by [Leshan](#) manufacturer:

Other Similar products are found below :

[LV5684PVD-XH](#) [MCDTSA6-2R](#) [L7815ACV-DG](#) [LV56801P-E](#) [UA7805CKC](#) [714954EB](#) [ZMR500QFTA](#) [BA033LBSG2-TR](#)

[NCV78M05ABDTRKG](#) [LV5680P-E](#) [L79M05T-E](#) [L78LR05D-MA-E](#) [NCV317MBTG](#) [NTE7227](#) [MP2018GZD-33-P](#) [MP2018GZD-5-P](#)

[LV5680NPVC-XH](#) [ZTS6538SE](#) [UA78L09CLP](#) [UA78L09CLPR](#) [CAT6221-PPTD-GT3](#) [MC78M09CDTRK](#) [NCV51190MNTAG](#)

[BL1118CS8TR1833](#) [BL8563CKETR18](#) [BL8077CKETR33](#) [BL9153-33CC3TR](#) [BL9161G-15BADRN](#) [BL9161G-28BADRN](#)

[BRCO7530MMC](#) [CJ7815B-TFN-ARG](#) [LM317C](#) [GM7333K](#) [GM7350K](#) [XC6206P332MR](#) [HT7533](#) [LM7912S/TR](#) [LT1764S/TR](#) [LM7805T](#)

[LM338T](#) [LM1117IMP-3.3/TR](#) [HT1117AM-3.3](#) [HT7550S](#) [AMS1117-3.3](#) [HT7150S](#) [78L12](#) [HT7550](#) [HT7533-1](#) [HXY6206I-2.5](#) [HT7133](#)