

**Ultra Fast High PSRR
Low Noise CMOS Voltage Regulator**

LR6205 Series

■ INTRODUCTION

The LR6205 series are a group of positive voltage regulators manufactured by CMOS technologies with high ripple rejection, ultra low noise, low power consumption and low dropout voltage, which can prolong battery life in portable electronics. The LR6205 series work with low-ESR ceramic capacitors, reducing the amount of board space necessary for power applications. The LR6205 series consume less than 0.1uA in shutdown mode and have fast turn-on time less than 50us. The series are very suitable for the battery-powered equipments, such as RF applications and other systems requiring a quiet voltage source.

■ APPLICATIONS

- Cellular and Smart Phones
- Laptop, Palmtops and PDA
- Digital Still and Video Cameras

■ FEATURES

- Low Output Noise: $40\mu V_{RMS}$ (10Hz~100kHz)
- Low Dropout Voltage: 150mV@150mA
- Low Quiescent Current: 50uA
- High Ripple Rejection: 75dB@1kHz
- Excellent Line and Load Transient Response
- Operating Voltage: 2.0V~6.0V
- Output Voltage: 1.2 ~ 5.0V
- High Accuracy: $\pm 2\%$ (Typ.)
- Built-in Current Limiter, Short-Circuit Protection
- TTL- Logic-Controlled Shutdown Input

- MP3, MP4 Player
- Radio control systems
- Battery-Powered Equipment

■ BLOCK DIAGRAM

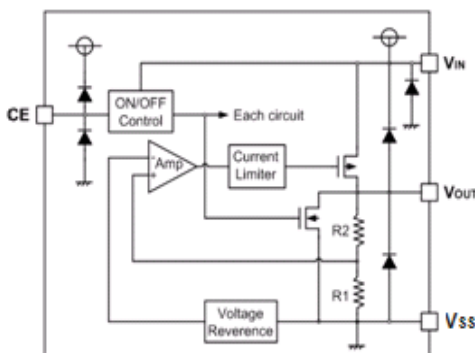

■ ORDER INFORMATION

LR6205①②③④

DESIGNATOR	SYMBOL	DESCRIPTION
①	A	Standard
	B	High Active, pull-down resistor built in, with C _{OUT} discharge resistor
	C	High Active, No pull-down resistor, No C _{OUT} discharge resistor
②③	Integer	Output Voltage e.g.1.8V=②:1, ③:8
④	M	Package:SOT-23-3/5
	U	Package:SC-70-5
	P	Package:SOT-89-3/5
	F	Package:DFN1X1-4

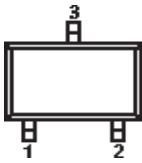
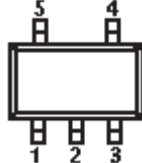
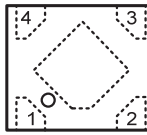
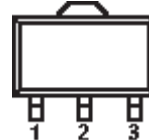
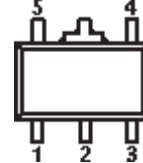
■ PIN CONFIGURATION
SOT-23-3

SOT-23-5/SC-70-5

DFN1X1-4

SOT-89-3

SOT-89-5

PIN NUMBER						PIN NAME	FUNCTION
SOT-23-3			SOT-89-3				
M	MA	MC	MY	P	PT		
1	2	3	3	1	2	V_{SS}	Ground
2	1	2	1	3	1	V_{OUT}	Output
3	3	1	2	2	3	V_{IN}	Power input

SOT-23-5/SC-70-5

PIN NUMBER			SYMBOL	FUNCTION
M	MF	ML		
1	1	5	V_{IN}	Power Input Pin
2	2	2	V_{SS}	Ground
3	—	1	CE	Chip Enable Pin
4	3/4	3	NC	No Connection
5	5	4	V_{OUT}	Output Pin

SOT-89-5

PIN NUMBER	SYMBOL	FUNCTION
1	V_{OUT}	Output Pin
2	V_{SS}	Ground
3	NC	No Connection
4	CE	Chip Enable Pin
5	V_{IN}	Power Input Pin

DFN1x1-4

PIN NUMBER	SYMBOL	FUNCTION
F		
1	V_{OUT}	Output Pin
2	V_{SS}	Ground
3	CE	Chip Enable Pin
4	V_{IN}	Power Input Pin

■ TYPICAL APPLICATION

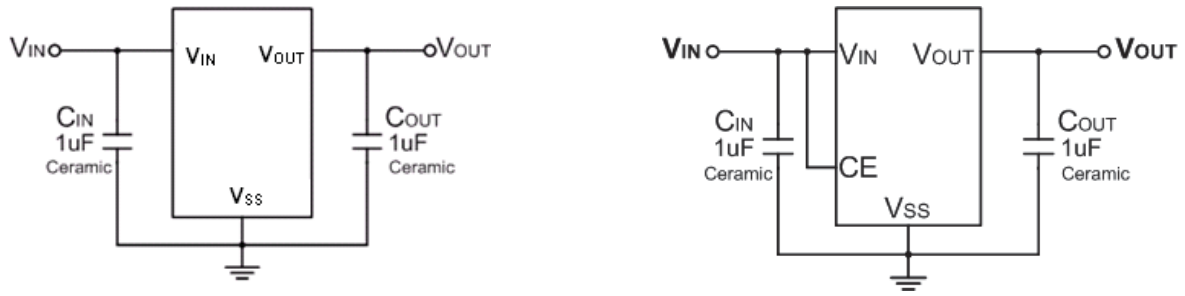

■ ABSOLUTE MAXIMUM RATINGS

 (Unless otherwise specified, $T_a=25^\circ\text{C}$)

PARAMETER	SYMBOL	RATINGS	UNITS
Input Voltage	V_{IN}	$V_{SS} - 0.3 \sim V_{SS} + 7$	V
Output Current	I_{OUT}	600	mA
Output Voltage	V_{OUT}	$V_{SS} - 0.3 \sim V_{IN} + 0.3$	V
Power Dissipation	SOT-23	P_d	370
	SC-70	P_d	250
	SOT-89	P_d	500
	DFN1x1-4	P_d	400
Operating Temperature	T_{opr}	$-40 \sim +85$	$^\circ\text{C}$
Storage Temperature	T_{stg}	$-40 \sim +125$	$^\circ\text{C}$
Soldering Temperature & Time	T_{solder}	$260^\circ\text{C}, 10\text{s}$	

■ ELECTRICAL CHARACTERISTICS

L6205 Series ($V_{IN}=V_{OUT}+1\text{V}$, $C_{IN}=C_{OUT}=1\mu\text{F}$, $T_a=25^\circ\text{C}$, unless otherwise specified)

PARAMETER	SYMBOL	CONDITIONS	MIN.	TYP.	MAX.	UNITS
Output Voltage	$V_{OUT(E)}$ (Note 2)	$I_{OUT}=1\text{mA}$	V_{OUT} *0.98	V_{OUT}	V_{OUT} *1.02	V
Supply Current	I_{SS}	$I_{OUT}=0$		50	100	μA
Standby Current	I_{STBY}	$CE = V_{SS}$			0.1	μA
Output Current	I_{OUT}	—	500			mA
Dropout Voltage (Note 3)	V_{dif}	$I_{OUT} = 150\text{mA}$ $V_{OUT} \geq 2.8\text{V}$		150		mV
Load Regulation	ΔV_{OUT}	$V_{IN} = V_{OUT} + 1\text{V}$, $1\text{mA} \leq I_{OUT} \leq 100\text{mA}$		10		mV
Line Regulation	$\frac{\Delta V_{OUT}}{V_{OUT} \times \Delta V_{IN}}$	$I_{OUT} = 10\text{mA}$ $V_{OUT} + 1\text{V} \leq V_{IN} \leq 6\text{V}$		0.01	0.2	%/V
Output Voltage Temperature Characteristics	$\frac{\Delta V_{OUT}}{\Delta T \times V_{OUT}}$	$I_{OUT} = 10\text{mA}$ $-40 \leq T \leq +85$		100		ppm
Short Current	I_{Short}	$V_{OUT} = V_{SS}$		100		mA
Input Voltage	V_{IN}	—	2.0		6.0	V

■ ELECTRICAL CHARACTERISTICS

LR6205 Series ($V_{IN}=V_{OUT}+1V$, $C_{IN}=C_{OUT}=1\mu F$, $T_a=25^\circ C$, unless otherwise specified)

PARAMETER		SYMBOL	CONDITIONS	MIN.	TYP.	MAX.	UNITS
Power Supply Rejection Rate	217Hz	PSRR	$I_{OUT}=50mA$		80		dB
	1kHz				75		
	10kHz				70		
CE "High" Voltage		$V_{CE} "H"$		1.5		V_{IN}	V
CE "Low" Voltage		$V_{CE} "L"$				0.3	V

NOTE:

1. V_{OUT} : Specified Output Voltage.
2. $V_{OUT} (E)$: Effective Output Voltage (i.e. The Output Voltage When $V_{IN} = (V_{OUT} + 1.0V)$ And Maintain A Certain I_{OUT} Value).
3. V_{dif} : The Difference Of Output Voltage And Input Voltage When Input Voltage Is Decreased Gradually Till Output Voltage Equals To 98% Of $V_{OUT} (E)$.

■ DROPOUT VOLTAGE CHART

Setting Output Voltage	Dropout Voltage(mV) @ $I_{OUT}=150mA$	
$V_{OUT}(V)$	Typ.	Max.
1.2	380	600
1.5	270	600
1.8	230	600
2.5	180	400
2.8	160	220
3.0	155	220
3.3	150	220

■ TYPICAL PERFORMANCE CHARACTERISTICS

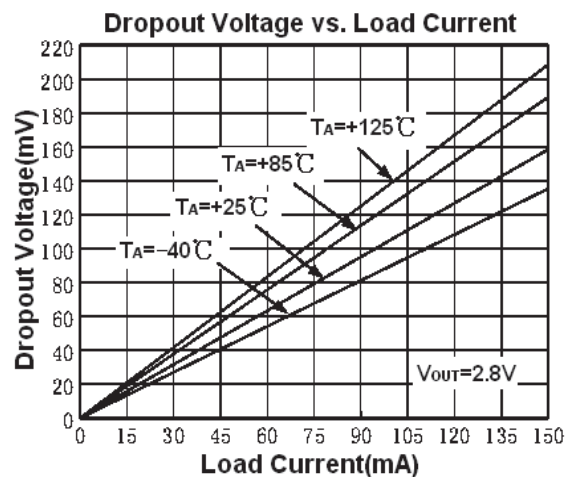
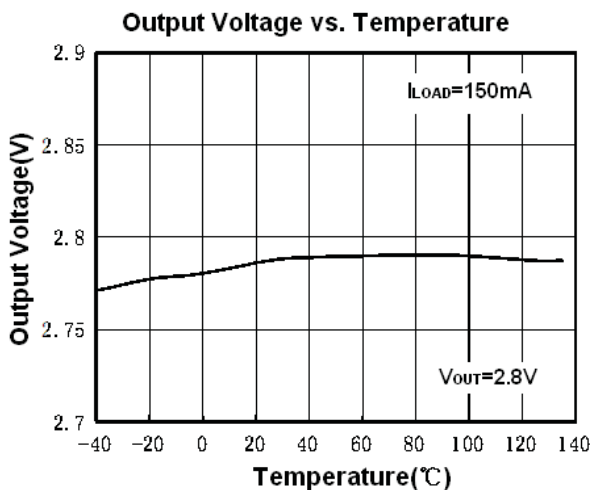

■ TYPICAL PERFORMANCE CHARACTERISTICS

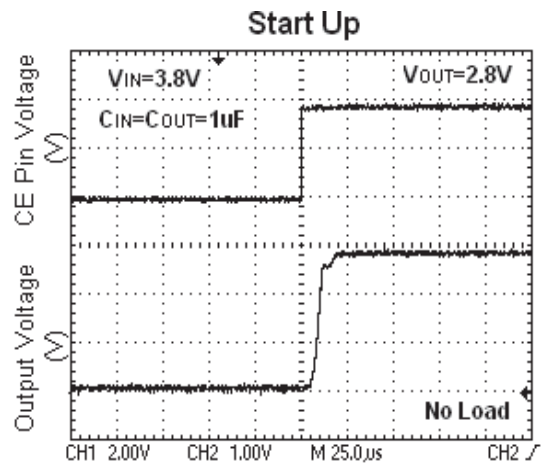
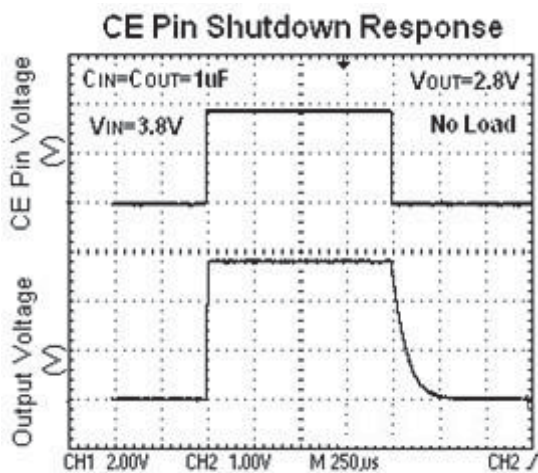
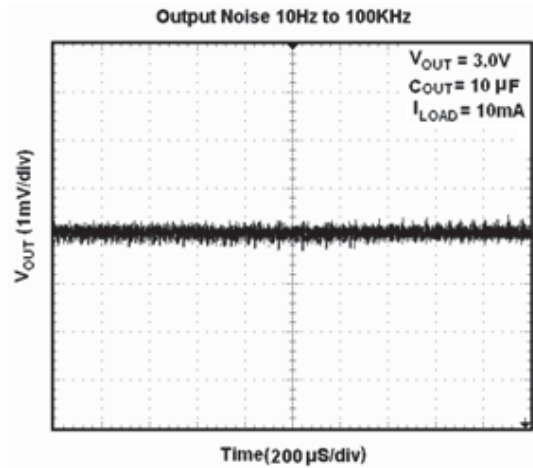
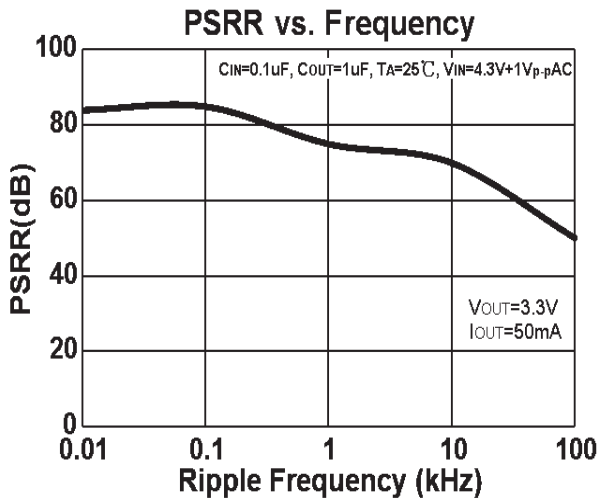
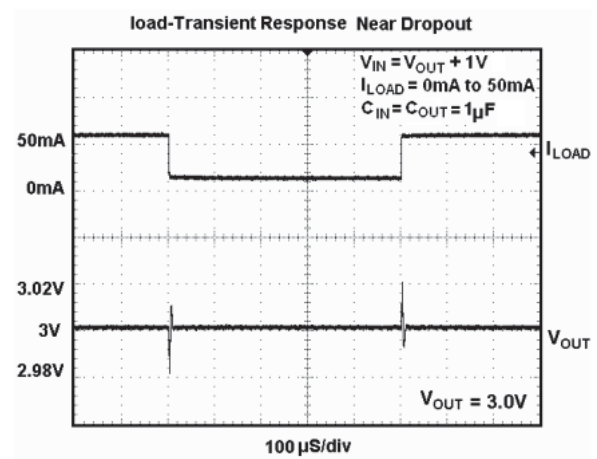
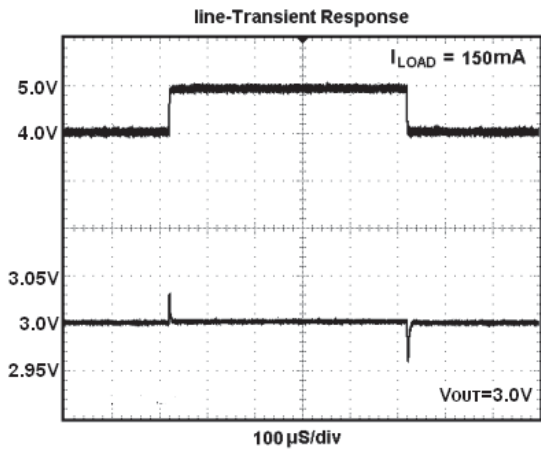

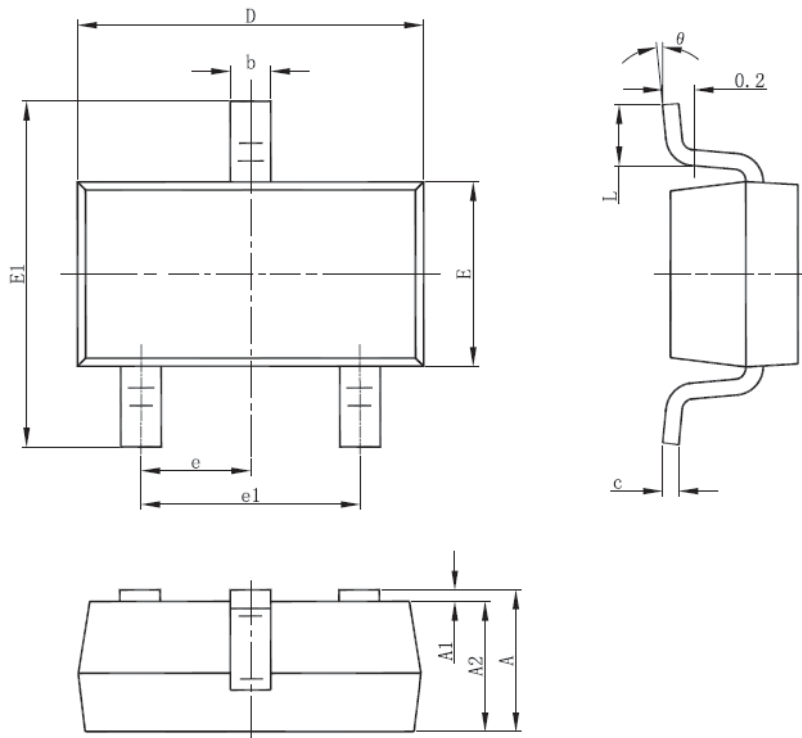
■ PACKAGING INFORMATION
● SOT-23-3 PACKAGE OUTLINE DIMENSIONS

Symbol	Dimensions In Millimeters		Dimensions In Inches	
	Min	Max	Min	Max
A	1.050	1.250	0.041	0.049
A1	0.000	0.100	0.000	0.004
A2	1.050	1.150	0.041	0.045
b	0.300	0.500	0.012	0.020
c	0.100	0.200	0.004	0.008
D	2.820	3.020	0.111	0.119
E	1.500	1.700	0.059	0.067
E1	2.650	2.950	0.104	0.116
e	0.950(BSC)		0.037(BSC)	
e1	1.800	2.000	0.071	0.079
L	0.300	0.600	0.012	0.024
θ	0°	8°	0°	8°

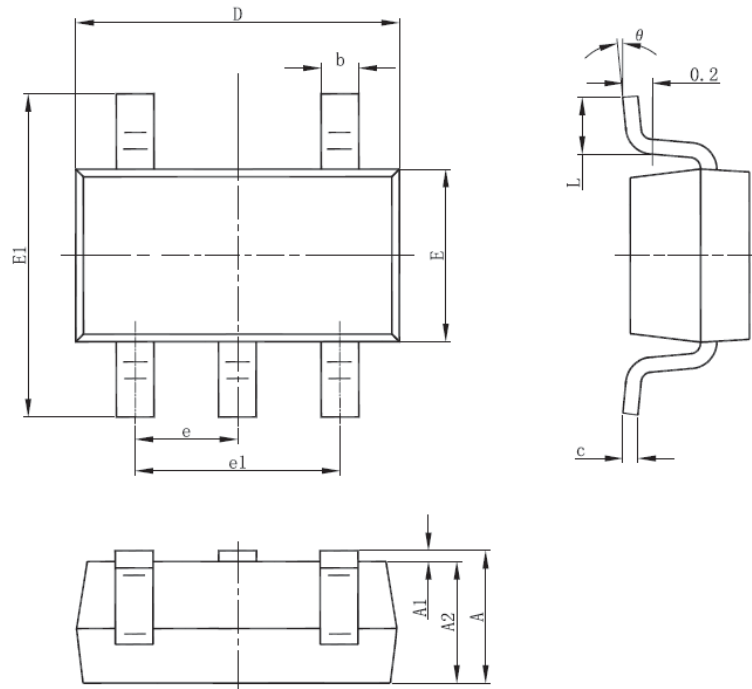
• SOT-23-5 PACKAGE OUTLINE DIMENSIONS

Symbol	Dimensions In Millimeters		Dimensions In Inches	
	Min	Max	Min	Max
A	1.050	1.250	0.041	0.049
A1	0.000	0.100	0.000	0.004
A2	1.050	1.150	0.041	0.045
b	0.300	0.500	0.012	0.020
c	0.100	0.200	0.004	0.008
D	2.820	3.020	0.111	0.119
E	1.500	1.700	0.059	0.067
E1	2.650	2.950	0.104	0.116
e	0.950(BSC)		0.037(BSC)	
e1	1.800	2.000	0.071	0.079
L	0.300	0.600	0.012	0.024
θ	0°	8°	0°	8°

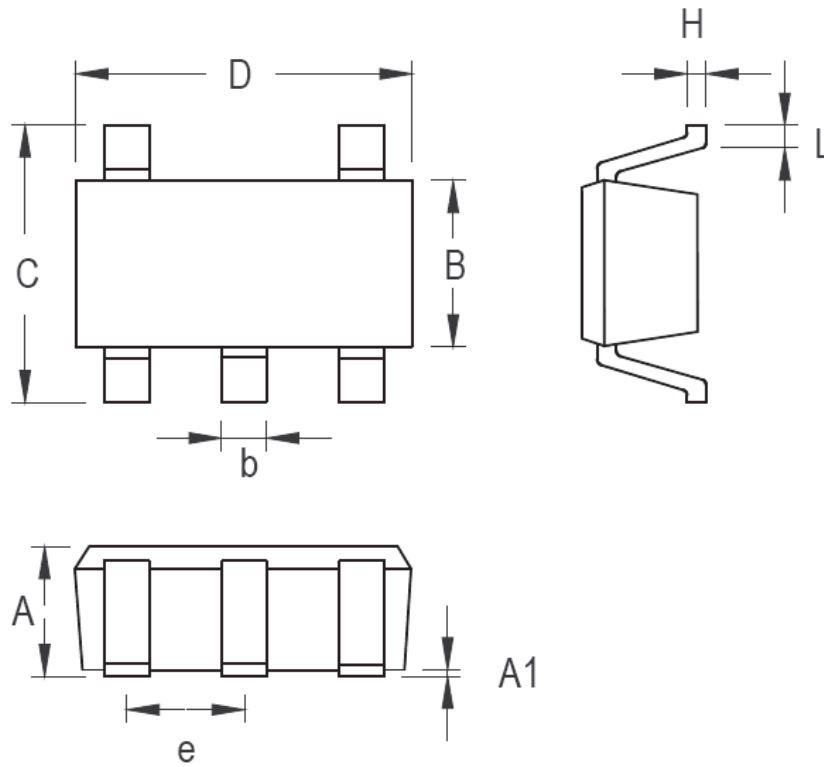
• SC-70-5 PACKAGE OUTLINE DIMENSIONS

Symbol	Dimensions In Millimeters		Dimensions In Inches	
	Min	Max	Min	Max
A	0.800	1.100	0.031	0.044
A1	0.000	0.100	0.000	0.004
B	1.150	1.350	0.045	0.054
b	0.150	0.400	0.006	0.016
C	1.800	2.450	0.071	0.096
D	1.800	2.250	0.071	0.089
e	0.650		0.026	
H	0.080	0.260	0.003	0.010
L	0.210	0.460	0.008	0.018

- SOT-89-3 PACKAGE OUTLINE DIMENSIONS

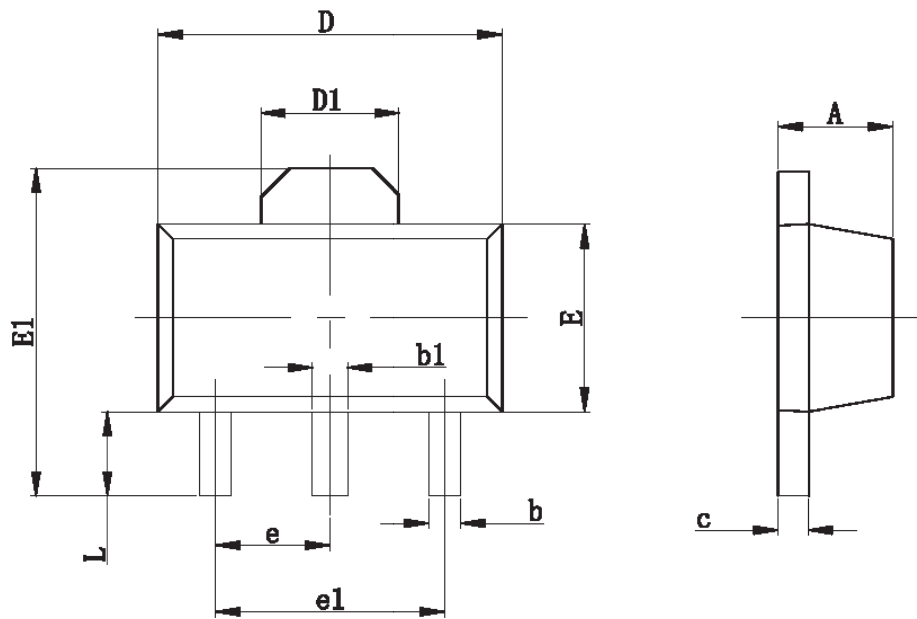

Symbol	Dimensions In Millimeters		Dimensions In Inches	
	Min	Max	Min	Max
A	1.400	1.600	0.055	0.063
b	0.320	0.520	0.013	0.197
b1	0.400	0.580	0.016	0.023
c	0.350	0.440	0.014	0.017
D	4.400	4.600	0.173	0.181
D1	1.550 REF		0.061 REF	
E	2.300	2.600	0.091	0.102
E1	3.940	4.250	0.155	0.167
e	1.500 TYP		0.060TYP	
e1	3.000 TYP		0.118TYP	
L	0.900	1.200	0.035	0.047

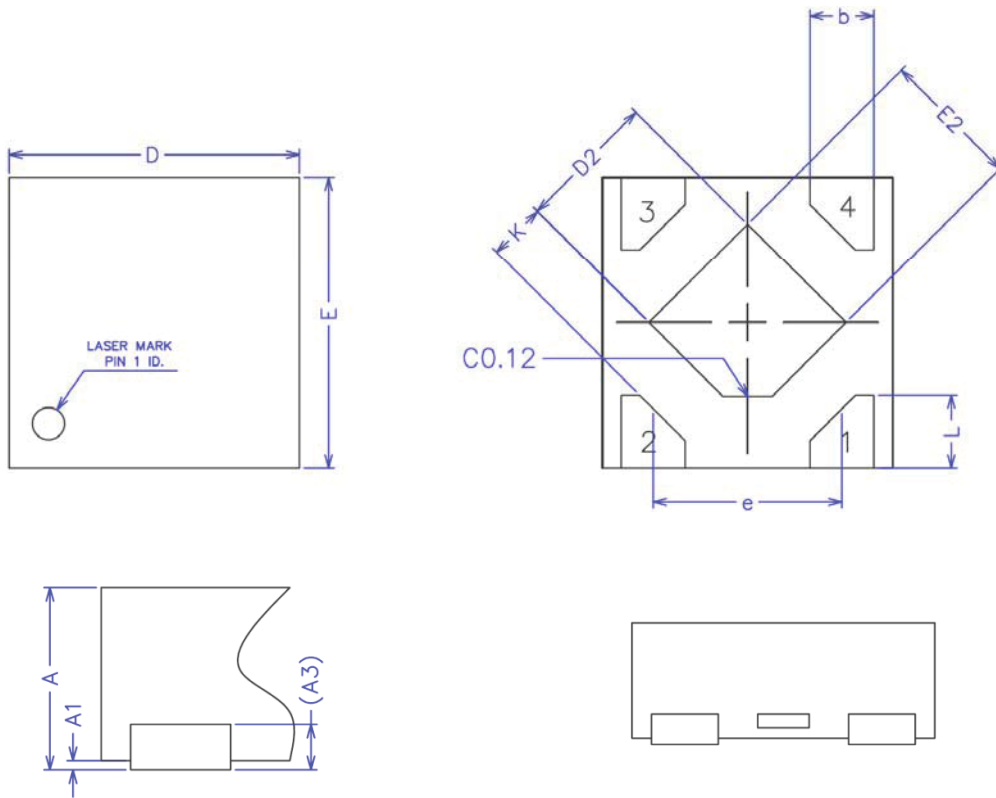
● DFN1X1-4 PACKAGE OUTLINE DIMENSIONS

COMMON DIMENSIONS
(UNITS OF MEASURE=MILLIMETER)

SYMBOL	MIN	NOM	MAX
A	0.34	0.37	0.40
A1	0.00	0.02	0.05
A3	0.100REF		
b	0.17	0.22	0.27
D	0.95	1.00	1.05
E	0.95	1.00	1.05
D2	0.43	0.48	0.53
E2	0.43	0.48	0.53
L	0.20	0.25	0.30
e	—	0.65	—
K	0.15	—	—

- SOT-89-5 PACKAGE OUTLINE DIMENSIONS

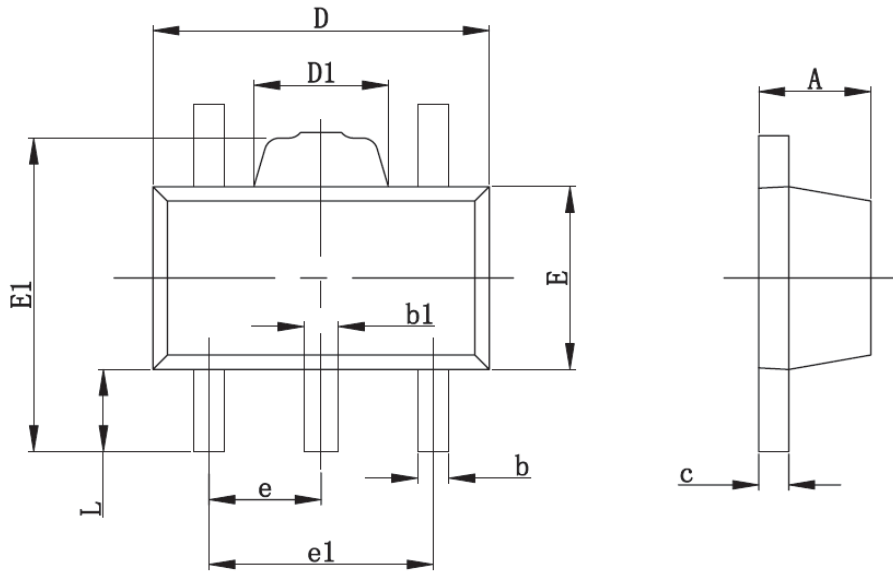

Symbol	Dimensions In Millimeters		Dimensions In Inches	
	Min	Max	Min	Max
A	1.400	1.600	0.055	0.063
b	0.320	0.520	0.013	0.020
b1	0.360	0.560	0.014	0.022
c	0.350	0.440	0.014	0.017
D	4.400	4.600	0.173	0.181
D1	1.400	1.800	0.055	0.071
E	2.300	2.600	0.091	0.102
E1	3.940	4.250	0.155	0.167
e	1.500TYP		0.060TYP	
e1	2.900	3.100	0.114	0.122
L	0.900	1.100	0.035	0.043

X-ON Electronics

Largest Supplier of Electrical and Electronic Components

Click to view similar products for [LDO Voltage Regulators](#) category:

Click to view products by [Leshan](#) manufacturer:

Other Similar products are found below :

[M38D29FFHP#U1](#) [702103A](#) [717726C](#) [742457H](#) [MP20051DN-LF-Z](#) [R5F111PGGFB#30](#) [AP7363-SP-13](#) [NCP103AMX285TCG](#)
[NCV8664CST33T3G](#) [NCV8752AMX28TCG](#) [L9454](#) [AP7362-HA-7](#) [LX13043CLD](#) [TCR3DF185,LM\(CT](#) [TCR3DF24,LM\(CT](#)
[TCR3DF285,LM\(CT](#) [TCR3DF31,LM\(CT](#) [TCR3DF45,LM\(CT](#) [TLF4949EJ](#) [L9708](#) [L970813TR](#) [030014BB](#) [059985X](#) [EAN61387601](#)
[EAN61573601](#) [NCP121AMX173TCG](#) [NCP4687DH15T1G](#) [NCV8703MX30TCG](#) [701326R](#) [702087BB](#) [755078E](#) [TCR2EN28,LF\(S](#)
[LM1117DT-1.8/NO](#) [LT1086CM#TRPBF](#) [AZ1085S2-1.5TRE1](#) [MAX15101EWL+T](#) [NCV8170AXV250T2G](#) [SCD337BTG](#)
[TCR3DF27,LM\(CT](#) [TCR3DF19,LM\(CT](#) [TCR3DF125,LM\(CT](#) [TCR2EN18,LF\(S](#) [MAX15103EWL+T](#) [TS2937CZ-5.0 C0](#) [MAX8878EUK30-](#)
[T](#) [MAX663CPA](#) [NCV4269CPD50R2G](#) [NCV8716MT30TBG](#) [AZ1117IH-1.2TRG1](#) [MP2013GQ-P](#)