

**36V Low Current Consumption
250mA CMOS Voltage Regulator**

LR6375 Series

■ INTRODUCTION

The LR6375 series are a group of positive voltage regulators manufactured by CMOS technologies with low power consumption and low dropout voltage, which provide large output currents even when the difference of the input-output voltage is small. The LR6375 series can deliver 250mA output current and allow an input voltage as high as 36V. The series are very suitable for the battery-powered equipments, such as RF applications and other systems requiring a quiet voltage source.

■ APPLICATIONS

- Cordless Phones
- Radio control systems
- Laptop, Palmtops and PDAs
- Single-lens reflex DSC
- PC peripherals with memory

■ BLOCK DIAGRAM

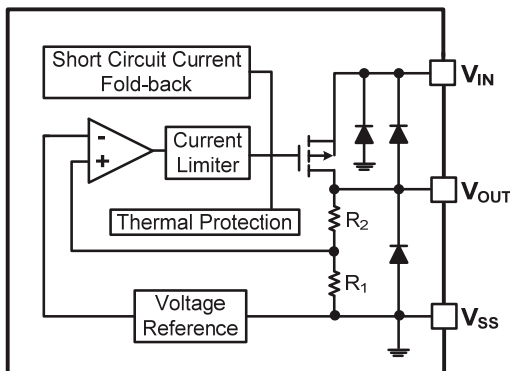

■ FEATURES

- Low Quiescent Current: 2μA
 - Operating Voltage Range: 2.5V~36V
 - Output Current: 250mA
 - Low Dropout Voltage:
400mV@100mA(V_{OUT}=3.3V)
 - Output Voltage: 1.8~ 5.0V
 - High Accuracy: ±2%/±1%(Typ.)
 - High Power Supply Rejection Ratio:
70dB@1kHz
 - Low Output Noise:
27xV_{OUT} μV_{RMS}(10Hz~100kHz)
 - Excellent Line and Load Transient Response
 - Built-in Current Limiter, Short-Circuit Protection
 - Over-Temperature Protection
 - Stable with Ceramic or Tantalum Capacitor
-
- Wireless Communication Equipments
 - Portable Audio Video Equipments
 - Car Navigation Systems
 - LAN Cards
 - Ultra Low Power Microcontrolle

■ ORDER INFORMATION

LR6375①②③④⑤

DESIGNATOR	SYMBOL	DESCRIPTION
①	A	Without EN
②③	Integer	Output Voltage e.g.5.0V= ②:5 ③:0
④	M/MC/MY	Package:SOT-23-3
	MF/MR	Package:SOT-23-5
	P/PT/PL	Package:SOT-89-3
⑤		2% Accuracy
	1	1% Accuracy

■ PIN CONFIGURATION

SOT-23-3

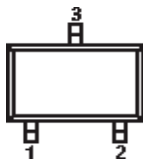

SOT-23-5

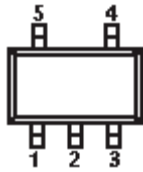

SOT-89-3

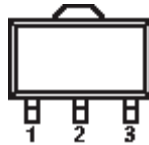

PIN NUMBER						PIN NAME	FUNCTION
SOT-23-3			SOT-89-3				
M	MC	MY	P	PT	PL		
1	3	3	1	2	2	V_{SS}	Ground
2	2	1	3	1	3	V_{OUT}	Output
3	1	2	2	3	1	V_{IN}	Power input

SOT-23-5

PIN NUMBER		PIN NAME	FUNCTION
MF	MR		
1	2	V_{IN}	Power Input
2	1	V_{SS}	Ground
3/4	4/5	NC	No Connection
5	3	V_{OUT}	Output

■ **ABSOLUTE MAXIMUM RATINGS⁽¹⁾**

(Unless otherwise specified, $T_A=25^{\circ}\text{C}$)

PARAMETER		SYMBOL	RATINGS	UNITS
Input Voltage ⁽²⁾		V_{IN}	-0.3~40	V
Output Voltage ⁽²⁾		V_{OUT}	-0.3~13	V
Power Dissipation	SOT-23	P_D	0.4	W
	SOT-89		0.6	W
Operating Junction Temperature Range ⁽³⁾		T_j	150	$^{\circ}\text{C}$
Storage Temperature		T_{stg}	-65~150	$^{\circ}\text{C}$
Lead Temperature(Soldering, 10 sec)		T_{solder}	260	$^{\circ}\text{C}$
ESD rating ⁽⁴⁾		Human Body Model -(HBM)	4~8	KV
		Machine Model- (MM)	200~400	V

(1) Stresses beyond those listed under *absolute maximum ratings* may cause permanent damage to the device. These are stress ratings only, and functional operation of the device at these or any other conditions beyond those indicated under *recommended operating conditions* is not implied. Exposure to absolute-maximum-rated conditions for extended periods may affect device reliability.

(2) All voltages are with respect to network ground terminal.

(3) This IC includes over temperature protection that is intended to protect the device during momentary overload. Junction temperature will exceed 125°C when over temperature protection is active. Continuous operation above the specified maximum operating junction temperature may impair device reliability.

(4) ESD testing is performed according to the respective JESD22 JEDEC standard.

■ **RECOMMENDED OPERATING CONDITIONS**

PARAMETER	MIN.	NOM.	MAX.	UNITS
Supply voltage at V_{IN}	2.5		36	V
Operating junction temperature range, T_j	-40		125	$^{\circ}\text{C}$
Operating free air temperature range, T_A	-40		85	$^{\circ}\text{C}$

■ ELECTRICAL CHARACTERISTICS

LR6375 Series ($V_{IN}=V_{OUT}+2V$, $C_{IN}=C_{OUT}=1\mu F$, $T_A=25^\circ C$, unless otherwise specified)

PARAMETER	SYMBOL	CONDITIONS	MIN.	TYP. ⁽⁵⁾	MAX.	UNITS	
Input Voltage	V_{IN}		2.5	—	36	V	
Output Voltage Range	V_{OUT}		1.8	—	5.0	V	
DC Output Accuracy		$I_{OUT}=10mA$	-2	—	2	%	
			-1	—	1	%	
Dropout Voltage	$V_{dif}^{(6)}$	$I_{OUT}=100mA, V_{OUT}=3.3V$	—	400	—	mV	
Supply Current	I_{SS}	$I_{OUT}=0A,$ $2.1V \leq V_{OUT} \leq 5.0V$	—	2	5	μA	
		$I_{OUT}=0A,$ $5.0V < V_{OUT} \leq 12.0V$	-	5	10	μA	
Line Regulation	$\frac{\Delta V_{OUT}}{V_{OUT} \times \Delta V_{IN}}$	$I_{OUT}=10mA$ $V_{OUT}+1V \leq V_{IN} \leq 36V$	—	0.01	0.3	%/V	
Load Regulation	ΔV_{OUT}	$V_{IN}=V_{OUT}+2V,$ $1mA \leq I_{OUT} \leq 100mA$	—	10	—	mV	
Temperature Coefficient	$\frac{\Delta V_{OUT}}{V_{OUT} \times \Delta T_A}$	$I_{OUT}=40mA,$ $-40^\circ C < T_A < 85^\circ C$		50		ppm/ $^\circ C$	
Output Current Limit	I_{LIM}	$V_{OUT}=0.5 \times V_{OUT(Normal)}$		350		mA	
Short Current	I_{SHORT}	$V_{OUT}=V_{SS}$	—	25	—	mA	
Power Supply Rejection Ratio	PSRR	$I_{OUT}=50mA$	100Hz		80		dB
			1kHz	—	70	—	
			10kHz	—	60	—	
			100kHz	—	50	—	
Output Noise Voltage	V_{ON}	BW=10Hz to 100kHz	—	$27 \times V_{OUT}$	—	μV_{RMS}	
Thermal Shutdown Temperature	T_{SD}	$I_{LOAD}=30mA$	—	160	—	$^\circ C$	
Thermal Shutdown Hysteresis	ΔT_{SD}	—	—	20	—	$^\circ C$	

(4) Typical numbers are at $25^\circ C$ and represent the most likely norm.

(5) V_{dif} : The Difference Of Output Voltage And Input Voltage When Input Voltage Is Decreased Gradually Till Output Voltage Equals To 98% Of V_{OUT} (E).

■ TYPICAL APPLICATION CIRCUIT

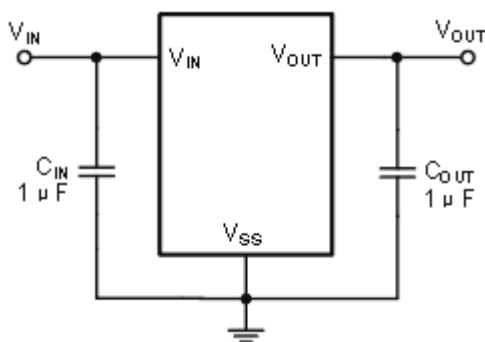

■ APPLICATION INFORMATION

Selection of Input/ Output Capacitors

In general, all the capacitors need to be low leakage. Any leakage the capacitors have will reduce efficiency, increase the quiescent current.

A recent trend in the design of portable devices has been to use ceramic capacitors to filter DC-DC converter inputs. Ceramic capacitors are often chosen because of their small size, low equivalent series resistance (ESR) and high RMS current capability. Also, recently, designers have been looking to ceramic capacitors due to shortages of tantalum capacitors.

Unfortunately, using ceramic capacitors for input filtering can cause problems. Applying a voltage step to a ceramic capacitor causes a large current surge that stores energy in the inductances of the power leads. A large voltage spike is created when the stored energy is transferred from these inductances into the ceramic capacitor. These voltage spikes can easily be twice the amplitude of the input voltage step. (See “Ceramic Input Capacitors Can Cause Overvoltage Transients”——Linear Technology application note 88, March 2001)

Many types of capacitors can be used for input bypassing, however, caution must be exercised when using multilayer ceramic capacitors (MLCC). Because of the self-resonant and high Q characteristics of some types of ceramic capacitors, high voltage transients can be generated under some start-up conditions, such as connecting the LDO input to a live power source. Adding a 3Ω resistor in series with an X5R ceramic capacitor will minimize start-up voltage transients.

The LDO also requires an output capacitor for loop stability. Connect a 1μF tantalum capacitor from OUT to GND close to the pins. For improved transient response, this output capacitor may be ceramic.

■ TYPICAL PERFORMANCE CHARACTERISTICS

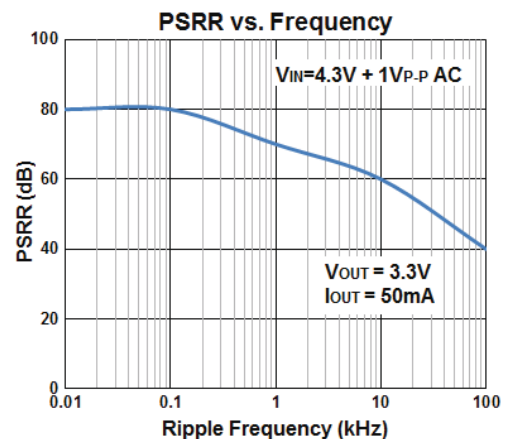
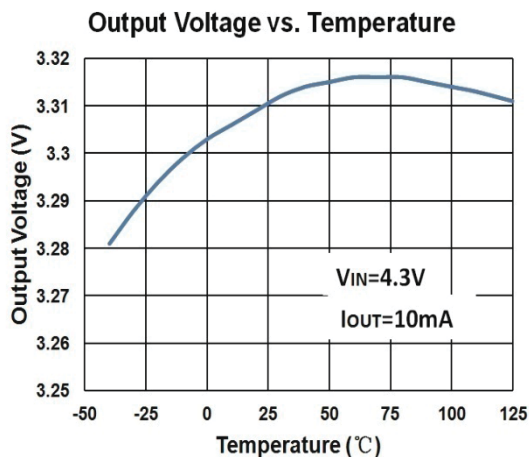

Line Regulation

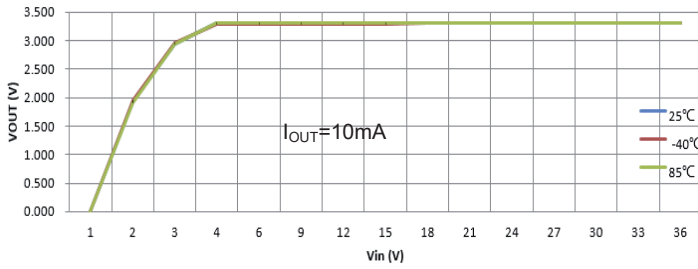

Load Regulation

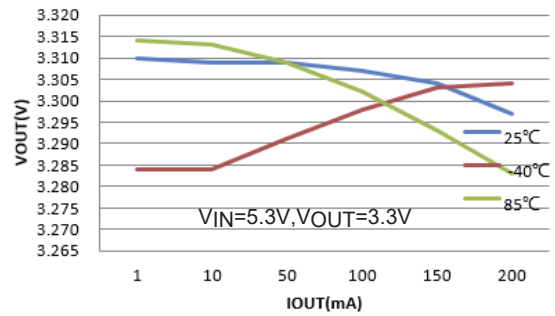

Dropout Voltage vs. Output Current

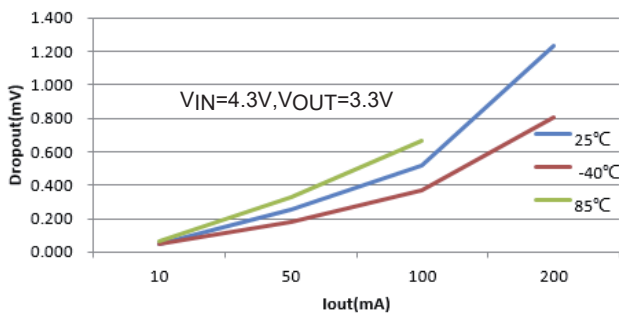

Ground Pin Current vs. Input Voltage

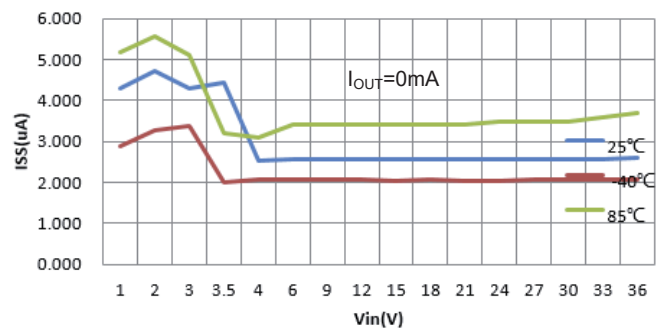

Output Voltage vs. Temperature

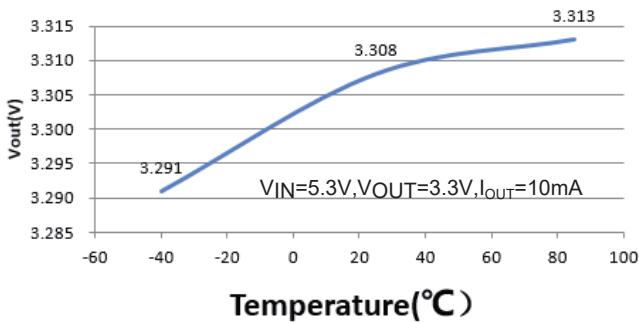

Ground Current vs. Temperature

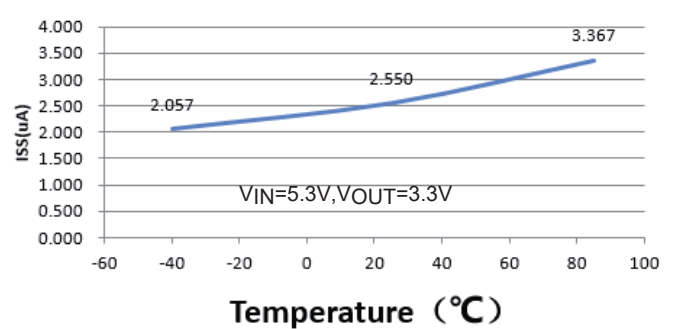

■ TYPICAL PERFORMANCE CHARACTERISTICS

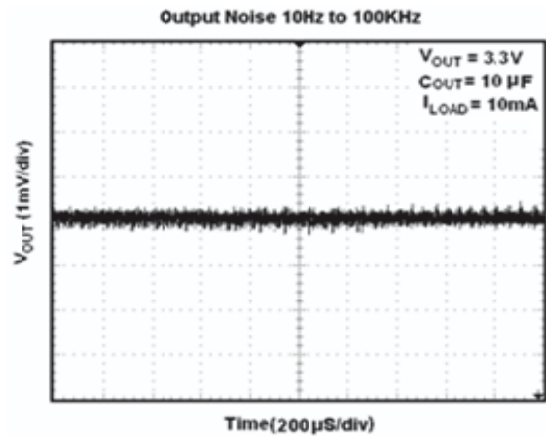
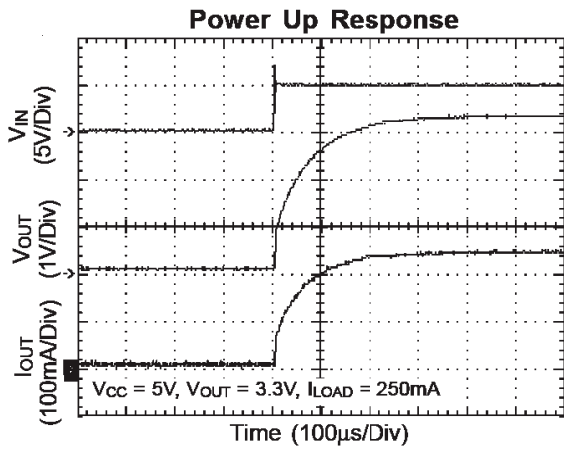
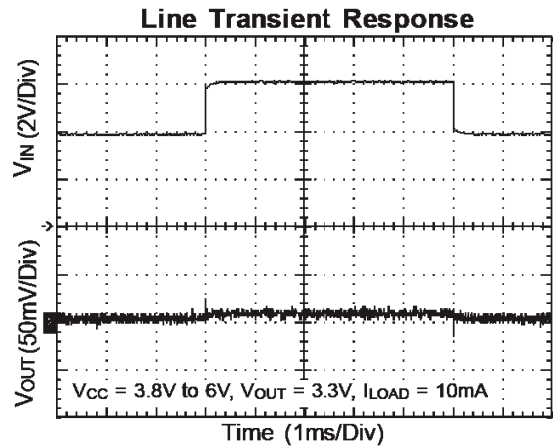
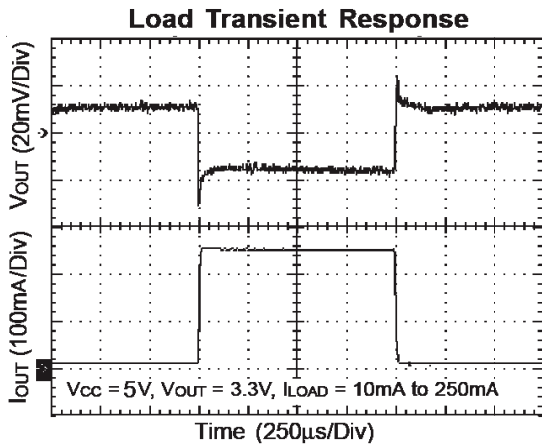

Ground Pin Current vs. Load Current

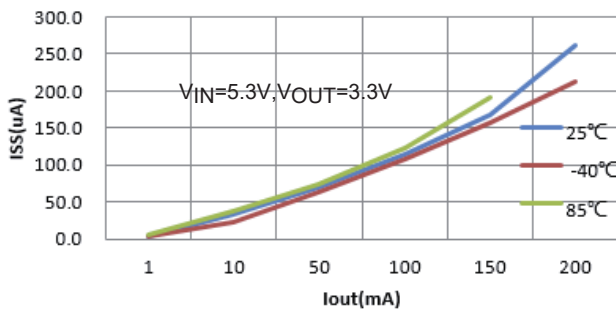

■ PACKAGING INFORMATION

● SOT-23-3 PACKAGE OUTLINE DIMENSIONS

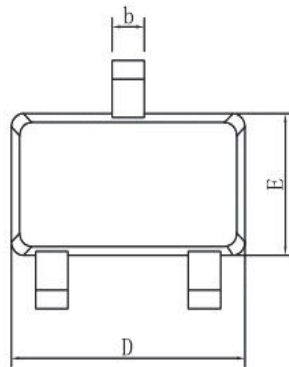
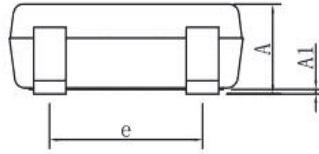
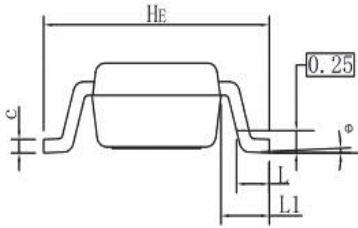

DIM	MIN	NOR	MAX
A	0.90	1.00	1.10
A1	0.01	0.06	0.10
b	0.30	0.40	0.50
c	0.10	0.17	0.20
D	2.80	2.90	3.00
E	1.50	1.60	1.70
e	1.80	1.90	2.00
L	0.20	0.40	0.60
L1	0.60REF		
HE	2.60	2.80	3.00
θ	0°	-	10°
All Dimensions in mm			

GENERAL NOTES

- 1.Top package surface finish Ra0.4±0.2um
- 2.Bottom package surface finish Ra0.7±0.2um
- 3.Side package surface finish Ra0.4±0.2um

SOLDERING FOOTPRINT

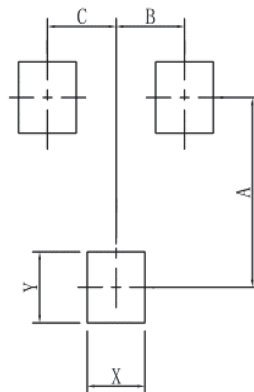

DIM	(mm)
X	0.80
Y	0.90
A	2.40
B	0.95
C	0.95

• SOT-23-5 PACKAGE OUTLINE DIMENSIONS

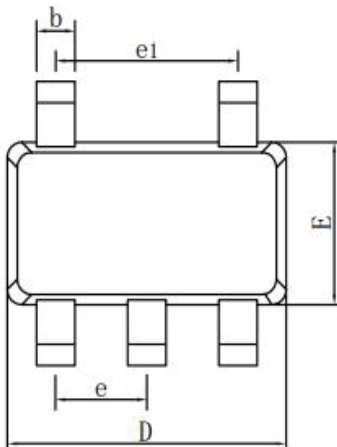
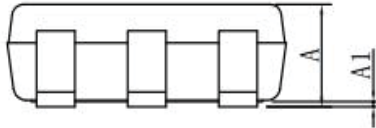
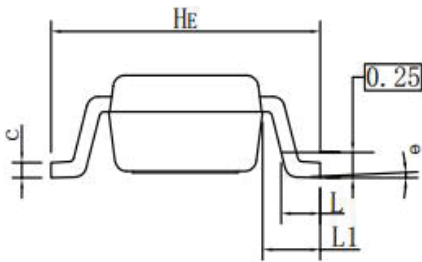

DIM	MIN	NOR	MAX
A	0.90	1.00	1.10
A1	0.01	0.06	0.10
b	0.30	0.40	0.50
c	0.10	0.17	0.20
D	2.80	2.90	3.00
E	1.50	1.60	1.70
e	0.85	0.95	1.05
e1	1.80	1.90	2.00
L	0.20	0.40	0.60
L1	0.60REF		
HE	2.60	2.80	3.00
θ	0°	-	10°

GENERAL NOTES

- 1.Top package surface finish Ra0.4±0.2um
- 2.Bottom package surface finish Ra0.7±0.2um
- 3.Side package surface finish Ra0.4±0.2um

SOLDERING FOOTPRINT

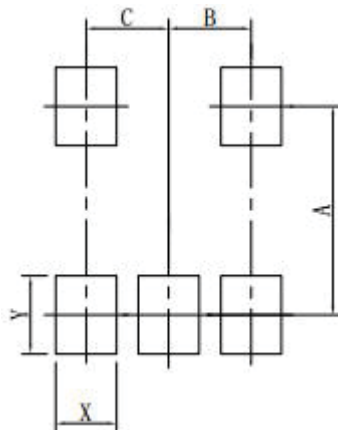

DIM	(mm)
X	0.70
Y	0.90
A	2.40
B	0.95
C	0.95

● SOT-89-3 PACKAGE OUTLINE DIMENSIONS

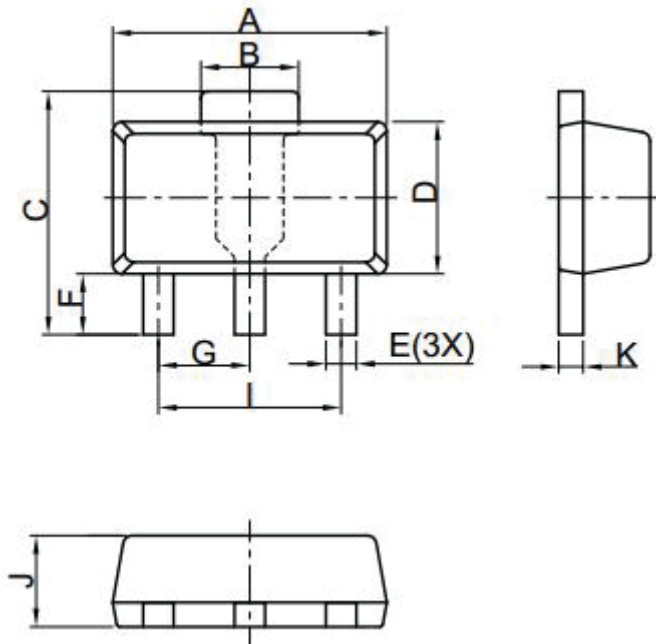

DIM	MIN	NOR	MAX
A	4.40	4.50	4.60
B	1.40	1.60	1.80
C	3.90	4.00	4.25
D	2.40	2.50	2.60
E	0.40	0.50	0.58
F	0.90	1.00	1.20
G	1.50 BSC		
I	3.00 BSC		
J	1.40	1.50	1.60
K	0.34	0.40	0.50
All Dimensions in mm			

GENERAL NOTES

1. Top package surface finish Ra0.4±0.2um
2. Bottom package surface finish Ra0.7±0.2um
3. Side package surface finish Ra0.4±0.2um
4. Protrusion or Gate Burrs shall not exceed 0.10mm per side.

SOLDERING FOOTPRINT

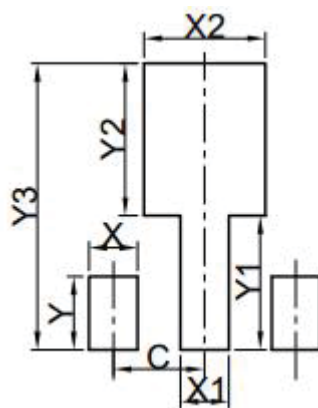

DIM	(mm)
X	0.80
Y	1.20
X1	0.80
Y1	2.20
X2	2.00
Y2	2.50
C	1.50
Y3	4.70

■ ORDER INFORMATION APPENDIX

Device ⁽⁷⁾	Output Voltage ⁽⁸⁾	Package	Marking ⁽⁹⁾⁽¹⁰⁾	Shipping
LR6375AxxM	1.8V~5V	SOT-23-3	8AX	3K/Reel
LR6375AxxMC	1.8V~5V	SOT-23-3	8CX	3K/Reel
LR6375AxxMY	1.8V~5V	SOT-23-3	8YX	3K/Reel
LR6375AxxMF	1.8V~5V	SOT-23-5	8BX	3K/Reel
LR6375AxxMR	1.8V~5V	SOT-23-5	8RX	3K/Reel
LR6375AxxP	1.8V~5V	SOT-89-3	8DX	1K/Reel
LR6375AxxPL	1.8V~5V	SOT-89-3	8LX	1K/Reel
LR6375AxxPT	1.8V~5V	SOT-89-3	8TX	1K/Reel
LR6375AxxP1	1.8V~5V	SOT-89-3	8ZX	1K/Reel

(7) : "xx" represents output voltage, eg "18" express that the output voltage is 1.8V

(8) : Output voltage varies from 1.8V to 12V, 0.1V an interval

(9) : The last letter "X" changes along with the output voltage, as figure below

(10) : There are additional marking, which relates to the date code

Voltage	1.0	1.2	1.5	1.8	2.5	2.7	2.8	3.0	3.3	3.6	4.0	4.2	5.0
Symble	D	E	F	G	H	I	J	K	L	M	N	T	P

■ TAPE AND REEL INFORMATION

REEL DEMENSIONS

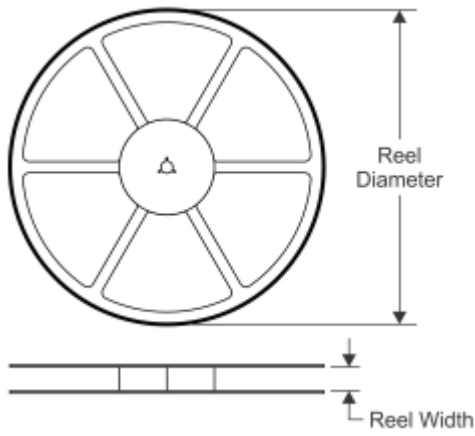

TAPE DIMENSIONS

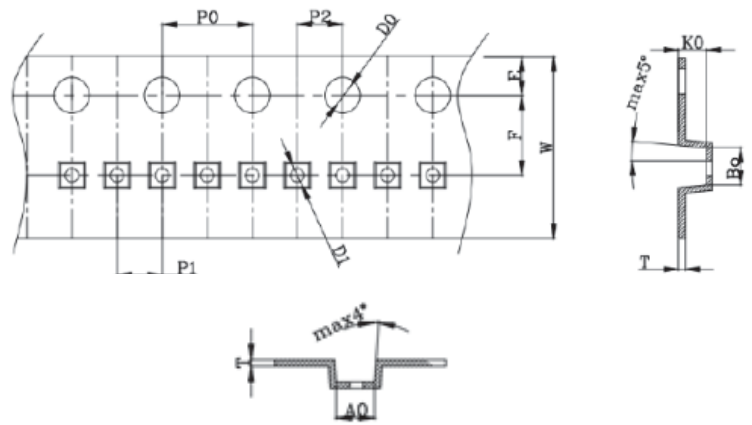

QUADRANT ASSIGNMENTS FOR PIN 1 ORIENTATION IN TAPE

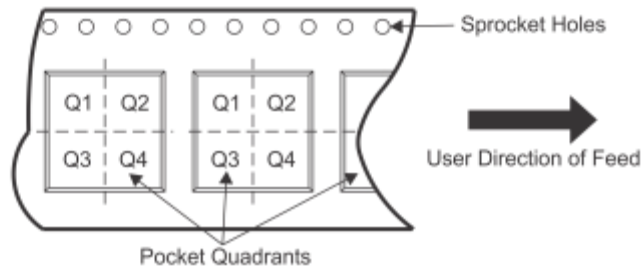

ROLLING ORIENTATION

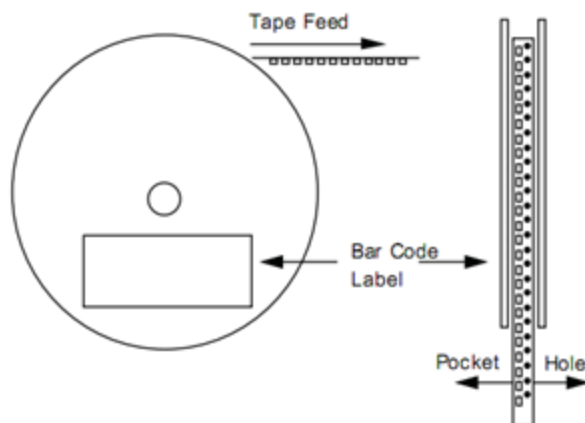

Device	Package	Reel Diameter (mm)	Reel width (mm)	P0 (mm)	P1 (mm)	A0 (mm)	B0 (mm)	K0 (mm)	W (mm)
LR6375AxxM	SOT-23-3	178±1	9.6±1.2	4.00±0.1	4.00±0.1	3.1±0.1	3.28±0.1	1.32±0.1	8.0±0.1
LR6375AxxMC	SOT-23-3	178±1	9.6±1.2	4.00±0.1	4.00±0.1	3.1±0.1	3.28±0.1	1.32±0.1	8.0±0.1
LR6375AxxMY	SOT-23-3	178±1	9.6±1.2	4.00±0.1	4.00±0.1	3.1±0.1	3.28±0.1	1.32±0.1	8.0±0.1
LR6375AxxMF	SOT-23-5	178±1	9.6±1.2	4.00±0.1	4.00±0.1	3.25±0.05	3.15±0.05	1.5±0.05	8.0±0.1
LR6375AxxMR	SOT-23-5	178±1	9.6±1.2	4.00±0.1	4.00±0.1	3.25±0.05	3.15±0.05	1.5±0.05	8.0±0.1
LR6375AxxP	SOT89-3	178±1	9.6±1.2	4.00±0.1	8.00±0.1	4.75±0.1	4.2±0.1	1.75±0.1	12.0 ^{+0.3} _{-0.1}
LR6375AxxPT	SOT89-3	178±1	13.0 ⁺¹ _{-0.5}	4.00±0.1	8.00±0.1	4.75±0.1	4.2±0.1	1.75±0.1	12.0 ^{+0.3} _{-0.1}
LR6375AxxPL	SOT89-3	178±1	13.0 ⁺¹ _{-0.5}	4.00±0.1	8.00±0.1	4.75±0.1	4.2±0.1	1.75±0.1	12.0 ^{+0.3} _{-0.1}
LR6375AxxP1	SOT89-3	178±1	13.0 ⁺¹ _{-0.5}	4.00±0.1	8.00±0.1	4.75±0.1	4.2±0.1	1.75±0.1	12.0 ^{+0.3} _{-0.1}

X-ON Electronics

Largest Supplier of Electrical and Electronic Components

Click to view similar products for [Linear Voltage Regulators](#) category:

Click to view products by [Leshan](#) manufacturer:

Other Similar products are found below :

[LV5684PVD-XH](#) [MCDTSA6-2R](#) [L7815ACV-DG](#) [LV56801P-E](#) [UA7805CKC](#) [714954EB](#) [ZMR500QFTA](#) [BA033LBSG2-TR](#)

[NCV78M05ABDTRKG](#) [LV5680P-E](#) [L79M05T-E](#) [L78LR05D-MA-E](#) [NCV317MBTG](#) [NTE7227](#) [MP2018GZD-33-P](#) [MP2018GZD-5-P](#)

[LV5680NPVC-XH](#) [ZTS6538SE](#) [UA78L09CLP](#) [UA78L09CLPR](#) [CAT6221-PPTD-GT3](#) [MC78M09CDTRK](#) [NCV51190MNTAG](#)

[BL1118CS8TR1833](#) [BL8563CKETR18](#) [BL8077CKETR33](#) [BL9153-33CC3TR](#) [BL9161G-15BADRN](#) [BL9161G-28BADRN](#)

[BRCO7530MMC](#) [CJ7815B-TFN-ARG](#) [LM317C](#) [GM7333K](#) [GM7350K](#) [XC6206P332MR](#) [HT7533](#) [LM7912S/TR](#) [LT1764S/TR](#) [LM7805T](#)

[LM338T](#) [LM1117IMP-3.3/TR](#) [HT1117AM-3.3](#) [HT7550S](#) [AMS1117-3.3](#) [HT7150S](#) [78L12](#) [HT7550](#) [HT7533-1](#) [HXY6206I-2.5](#) [HT7133](#)