

LR7800 Series 3-Terminal 1A Positive Voltage Regulators

DESCRIPTION

The LRC LR78XX family is monolithic fixed voltage regulator integrated circuit. They are suitable for applications that required supply current up to 1 A.

FEATURES

- *Output current up to 1A
- *Fixed output voltage of 5V, 6V, 7V, 8V, 9V, 10V, 12V, 15V, 18V and 24V available
- *Thermal overload shutdown protection
- *Short circuit current limiting

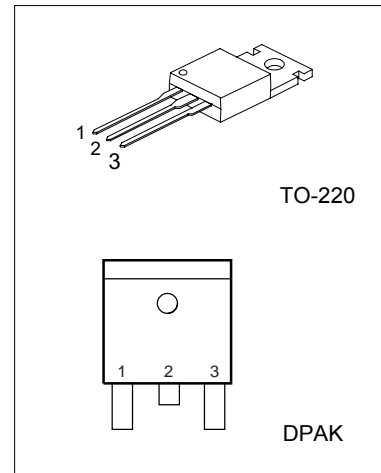

1: Input 2: GND 3: Output

ORDERING INFORMATION

- *LR78XX: TO220
- LR78XXD: TO252 (DPAK)

ABSOLUTE MAXIMUM RATINGS (Operating temperature range applies unless otherwise specified)

PARAMETER	SYMBOL	RATING	UNIT
Input voltage (for $V_o=5\sim 18V$) (for $V_o=24V$)	V_i	35	V
		40	V
Output Current	I_o	1	A
Power Dissipation	P_D	Internally Limited	W
Thermal Resistance Junction-Air	$R_{\theta JA}$ (TO220)	65	$^{\circ}C/W$
Thermal Resistance Junction-Air	$R_{\theta JA}$ (DPAK)	90	$^{\circ}C/W$
Operating Junction Temperature Range	T_{opr}	0 ~ +150	$^{\circ}C$
Operating Ambient Temperature	T_A	-40 ~ +125	$^{\circ}C$
Storage Temperature Range	T_{stg}	-55 ~ +150	$^{\circ}C$

ESD: HBM 2000V

APPLICATION CIRCUIT

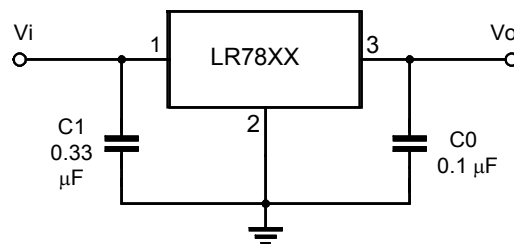

Note 1: To specify an output voltage, substitute voltage value for "XX".

Note 2: Bypass capacitors are recommended for optimum stability and transient response and should be located as close as possible to the regulators.

LR7800 Series 3-Terminal 1A Positive Voltage Regulators

LR7805 ELECTRICAL CHARACTERISTICS

($V_I=10V$, $I_o=0.5A$, $T_j=0^\circ C - 125^\circ C$, $C_1=0.33\mu F$, $C_o=0.1\mu F$, unless otherwise specified)(Note 1)

PARAMETER	SYMBOL	TEST CONDITIONS	MIN	TYP	MAX	UNIT
Output Voltage	V_o	$T_j=25^\circ C$, $I_o=5mA - 1.0A$	4.80	5.0	5.20	V
		$V_I=7.5V$ to $20V$, $I_o=5mA - 1.0A$, $P_D \leq 15W$	4.75		5.25	V
Load Regulation	ΔV_o	$T_j=25^\circ C$, $I_o=5mA - 1.0A$		9	100	mV
		$T_j=25^\circ C$, $I_o=0.25A - 0.75A$		4	50	mV
Line regulation	ΔV_o	$V_I=7V$ to $25V$, $T_j=25^\circ C$			100	mV
		$V_I=8V$ to $12V$, $T_j=25^\circ C$			50	mV
Quiescent Current	I_q	$T_j=25^\circ C$, $I_o \cong 1.0A$			8.0	mA
Quiescent Current Change	ΔI_q	$V_I=7.5V$ to $20V$			1.3	mA
		$I_o=5mA - 1.0A$			0.5	mA
Output Noise Voltage	V_N	$10Hz \leq f \leq 100kHz$		42		μV
Ripple Rejection	RR	$V_I=8V - 18V$, $f=120Hz$, $T_j=25^\circ C$	62	73		dB
Peak Output Current	I_{PK}	$T_j=25^\circ C$		1.8		A
Short-Circuit Current	I_{SC}	$V_I=35V$, $T_j=25^\circ C$		250		mA
Dropout Voltage	V_d	$T_j=25^\circ C$		2.0		V

LR7806 ELECTRICAL CHARACTERISTICS

($V_I=11V$, $I_o=0.5A$, $T_j=0^\circ C - 125^\circ C$, $C_1=0.33\mu F$, $C_o=0.1\mu F$, unless otherwise specified)(Note 1)

PARAMETER	SYMBOL	TEST CONDITIONS	MIN	TYP	MAX	UNIT
Output Voltage	V_o	$T_j=25^\circ C$, $I_o=5mA - 1.0A$	5.75	6.0	6.25	V
		$V_I=8.5V$ to $21V$, $I_o=5mA - 1.0A$, $P_D \leq 15W$	5.70		6.30	V
Load Regulation	ΔV_o	$T_j=25^\circ C$, $I_o=5mA - 1.0A$			120	mV
		$T_j=25^\circ C$, $I_o=0.25A - 0.75A$			60	mV
Line regulation	ΔV_o	$V_I=8V$ to $25V$, $T_j=25^\circ C$			120	mV
		$V_I=8.5V$ to $21V$, $T_j=25^\circ C$, $I_o=1.0A$			60	mV
Quiescent Current	I_q	$T_j=25^\circ C$, $I_o \cong 1.0A$			8.0	mA
Quiescent Current Change	ΔI_q	$V_I=8.5V$ to $21V$			1.3	mA
		$I_o=5mA - 1.0A$			0.5	mA
Output Noise Voltage	V_N	$10Hz \leq f \leq 100kHz$		45		μV
Ripple Rejection	RR	$V_I=9V - 19V$, $f=120Hz$, $T_j=25^\circ C$	59	75		dB
Peak Output Current	I_{PK}	$T_j=25^\circ C$		1.8		A
Short-Circuit Current	I_{SC}	$V_I=35V$, $T_j=25^\circ C$		550		mA
Dropout Voltage	V_d	$T_j=25^\circ C$		2.0		V

LR7800 Series 3-Terminal 1A Positive Voltage Regulators

LR7807 ELECTRICAL CHARACTERISTICS

($V_I=13V$, $I_o=0.5A$, $T_j=0^\circ C - 125^\circ C$, $C_1=0.33\mu F$, $C_o=0.1\mu F$, unless otherwise specified)(Note 1)

PARAMETER	SYMBOL	TEST CONDITIONS	MIN	TYP	MAX	UNIT
Output Voltage	V_o	$T_j=25^\circ C$, $I_o=5mA - 1.0A$	6.72	7.0	7.28	V
		$V_I=9.5V$ to $22V$, $I_o=5mA - 1.0A$, $P_D \leq 15W$	6.65		7.35	V
Load Regulation	ΔV_o	$T_j=25^\circ C$, $I_o=5mA - 1.0A$			120	mV
		$T_j=25^\circ C$, $I_o=0.25A - 0.75A$			60	mV
Line regulation	ΔV_o	$V_I=9V$ to $25V$, $T_j=25^\circ C$			120	mV
		$V_I=9.5V$ to $22V$, $T_j=25^\circ C$, $I_o=1.0A$			60	mV
Quiescent Current	I_q	$T_j=25^\circ C$, $I_o \leq 1.0A$			8.0	mA
Quiescent Current Change	ΔI_q	$V_I=9.5V$ to $22V$			1.0	mA
		$I_o=5mA - 1.0A$			0.5	mA
Output Noise Voltage	V_N	$10Hz \leq f \leq 100kHz$		50		μV
Ripple Rejection	RR	$V_I=10V - 20V$, $f=120Hz$, $T_j=25^\circ C$	59	75		dB
Peak Output Current	I_{PK}	$T_j=25^\circ C$		1.7		A
Short-Circuit Current	I_{SC}	$V_I=35V$, $T_j=25^\circ C$		250		mA
Dropout Voltage	V_d	$T_j=25^\circ C$		2.0		V

LR7808 ELECTRICAL CHARACTERISTICS

($V_I=14V$, $I_o=0.5A$, $T_j=0^\circ C - 125^\circ C$, $C_1=0.33\mu F$, $C_o=0.1\mu F$, unless otherwise specified)(Note 1)

PARAMETER	SYMBOL	TEST CONDITIONS	MIN	TYP	MAX	UNIT
Output Voltage	V_o	$T_j=25^\circ C$, $I_o=5mA - 1.0A$	7.68	8.0	8.32	V
		$V_I=10.5V$ to $23V$, $I_o=5mA - 1.0A$, $P_D \leq 15W$	7.60		8.40	V
Load Regulation	ΔV_o	$T_j=25^\circ C$, $I_o=5mA - 1.0A$			160	mV
		$T_j=25^\circ C$, $I_o=0.25A - 0.75A$			80	mV
Line regulation	ΔV_o	$V_I=10.5V$ to $25V$, $T_j=25^\circ C$			160	mV
		$V_I=10.5V$ to $23V$, $T_j=25^\circ C$, $I_o=1.0A$			80	mV
Quiescent Current	I_q	$T_j=25^\circ C$, $I_o \leq 1.0A$			8.0	mA
Quiescent Current Change	ΔI_q	$V_I=10.5V$ to $23V$			1.0	mA
		$I_o=5mA - 1.0A$			0.5	mA
Output Noise Voltage	V_N	$10Hz \leq f \leq 100kHz$		52		μV
Ripple Rejection	RR	$V_I=11.5V$ to $21.5V$, $f=120Hz$, $T_j=25^\circ C$	56	72		dB
Peak Output Current	I_{PK}	$T_j=25^\circ C$		1.8		A
Short-Circuit Current	I_{SC}	$V_I=35V$, $T_j=25^\circ C$		450		mA
Dropout Voltage	V_d	$T_j=25^\circ C$		2.0		V

LR7800 Series3-Terminal 1A Positive Voltage Regulators

LR7809 ELECTRICAL CHARACTERISTICS

($V_I=15V$, $I_o=0.5A$, $T_j=0^\circ C - 125^\circ C$, $C_1=0.33\mu F$, $C_o=0.1\mu F$, unless otherwise specified)(Note 1)

PARAMETER	SYMBOL	TEST CONDITIONS	MIN	TYP	MAX	UNIT
Output Voltage	V_o	$T_j=25^\circ C$, $I_o=5mA - 1.0A$	8.64	9.0	9.36	V
		$V_I=11.5V$ to $24V$, $I_o=5mA - 1.0A$, $P_D \leq 15W$	8.55		9.45	V
Load Regulation	ΔV_o	$T_j=25^\circ C$, $I_o=5mA - 1.0A$			180	mV
		$T_j=25^\circ C$, $I_o=0.25A - 0.75A$			90	mV
Line regulation	ΔV_o	$V_I=11.5V$ to $25V$, $T_j=25^\circ C$			180	mV
		$V_I=11.5V$ to $24V$, $T_j=25^\circ C$, $I_o=1.0A$			90	mV
Quiescent Current	I_q	$T_j=25^\circ C$, $I_o \leq 1.0A$			8.0	mA
Quiescent Current Change	ΔI_q	$V_I=11.5V$ to $24V$			1.0	mA
		$I_o=5mA - 1.0A$			0.5	mA
Output Noise Voltage	V_N	$10Hz \leq f \leq 100kHz$		58		μV
Ripple Rejection	RR	$V_I=12.5V$ to $22.5V$, $f=120Hz$, $T_j=25^\circ C$	56	70		dB
Peak Output Current	I_{PK}	$T_j=25^\circ C$		1.8		A
Short-Circuit Current	I_{SC}	$V_I=35V$, $T_j=25^\circ C$		400		mA
Dropout Voltage	V_d	$T_j=25^\circ C$		2.0		V

LR7810 ELECTRICAL CHARACTERISTICS

($V_I=16V$, $I_o=0.5A$, $T_j=0^\circ C - 125^\circ C$, $C_1=0.33\mu F$, $C_o=0.1\mu F$, unless otherwise specified)(Note 1)

PARAMETER	SYMBOL	TEST CONDITIONS	MIN	TYP	MAX	UNIT
Output Voltage	V_o	$T_j=25^\circ C$, $I_o=5mA - 1.0A$	9.60	10.0	10.40	V
		$V_I=12.5V$ to $25V$, $I_o=5mA - 1.0A$, $P_D \leq 15W$	9.50		10.50	V
Load Regulation	ΔV_o	$T_j=25^\circ C$, $I_o=5mA - 1.0A$			200	mV
		$T_j=25^\circ C$, $I_o=0.25A - 0.75A$			100	mV
Line regulation	ΔV_o	$V_I=13V$ to $25V$, $T_j=25^\circ C$			200	mV
		$V_I=13V$ to $25V$, $T_j=25^\circ C$, $I_o=1.0A$			100	mV
Quiescent Current	I_q	$T_j=25^\circ C$, $I_o \leq 1.0A$			8.0	mA
Quiescent Current Change	ΔI_q	$V_I=12.6V$ to $25V$			1.0	mA
		$I_o=5mA - 1.0A$			0.5	mA
Output Noise Voltage	V_N	$10Hz \leq f \leq 100kHz$		58		μV
Ripple Rejection	RR	$V_I=13V - 23V$, $f=120Hz$, $T_j=25^\circ C$	56	71		dB
Peak Output Current	I_{PK}	$T_j=25^\circ C$		1.8		A
Short-Circuit Current	I_{SC}	$V_I=35V$, $T_j=25^\circ C$		400		mA
Dropout Voltage	V_d	$T_j=25^\circ C$		2.0		V

LR7800 Series 3-Terminal 1A Positive Voltage Regulators

LR7812 ELECTRICAL CHARACTERISTICS

($V_I=19V$, $I_o=0.5A$, $T_j=0^\circ C - 125^\circ C$, $C_1=0.33\mu F$, $C_o=0.1\mu F$, unless otherwise specified)(Note 1)

PARAMETER	SYMBOL	TEST CONDITIONS	MIN	TYP	MAX	UNIT
Output Voltage	V_o	$T_j=25^\circ C$, $I_o=5mA - 1.0A$	11.5	12.0	12.5	V
		$V_I = 14.5V$ to $27V$, $I_o=5mA - 1.0A$, $P_D \leq 15W$	11.4		12.60	V
Load Regulation	ΔV_o	$T_j=25^\circ C$, $I_o=5mA - 1.0A$			240	mV
		$T_j=25^\circ C$, $I_o=0.25A - 0.75A$			120	mV
Line regulation	ΔV_o	$V_I = 14.5V$ to $30V$, $T_j=25^\circ C$			240	mV
		$V_I = 14.6V$ to $27V$, $T_j=25^\circ C$, $I_o=1.0A$			120	mV
Quiescent Current	I_q	$T_j=25^\circ C$, $I_o \leq 1.0A$			8.0	mA
Quiescent Current Change	ΔI_q	$V_I = 14.5V$ to $30V$			1.0	mA
		$I_o=5mA - 1.0A$			0.5	mA
Output Noise Voltage	V_N	$10Hz \leq f \leq 100kHz$		76		μV
Ripple Rejection	RR	$V_I = 15V - 25V$, $f=120Hz$, $T_j=25^\circ C$	55	71		dB
Peak Output Current	I_{PK}	$T_j=25^\circ C$		1.8		A
Short-Circuit Current	I_{SC}	$V_I=35V$, $T_j=25^\circ C$		230		mA
Dropout Voltage	V_d	$T_j=25^\circ C$		2.0		V

LR7815 ELECTRICAL CHARACTERISTICS

($V_I=23V$, $I_o=0.5A$, $T_j=0^\circ C - 125^\circ C$, $C_1=0.33\mu F$, $C_o=0.1\mu F$, unless otherwise specified)(Note 1)

PARAMETER	SYMBOL	TEST CONDITIONS	MIN	TYP	MAX	UNIT
Output Voltage	V_o	$T_j=25^\circ C$, $I_o=5mA - 1.0A$	14.40	15.0	15.60	V
		$V_I = 17.5V$ to $30V$, $I_o=5mA - 1.0A$, $P_D \leq 15W$	14.25		15.75	V
Load Regulation	ΔV_o	$T_j=25^\circ C$, $I_o=5mA - 1.0A$			300	mV
		$T_j=25^\circ C$, $I_o=0.25A - 0.75A$			150	mV
Line regulation	ΔV_o	$V_I = 18.5V$ to $30V$, $T_j=25^\circ C$			300	mV
		$V_I = 17.7V$ to $30V$, $T_j=25^\circ C$, $I_o = 1.0A$			150	mV
Quiescent Current	I_q	$T_j=25^\circ C$, $I_o \leq 1.0A$			8.0	mA
Quiescent Current Change	ΔI_q	$V_I = 17.5V$ to $30V$			1.0	mA
		$I_o=5mA - 1.0A$			0.5	mA
Output Noise Voltage	V_N	$10Hz \leq f \leq 100kHz$		90		μV
Ripple Rejection	RR	$V_I = 18.5V$ to $28.5V$ $f=120Hz$, $T_j=25^\circ C$	54	70		dB
Peak Output Current	I_{PK}	$T_j=25^\circ C$		1.8		A
Short-Circuit Current	I_{SC}	$V_I=35V$, $T_j=25^\circ C$		230		mA
Dropout Voltage	V_d	$T_j=25^\circ C$		2.0		V

LR7800 Series 3-Terminal 1A Positive Voltage Regulators

LR7818 ELECTRICAL CHARACTERISTICS

($V_I=27V$, $I_o=0.5A$, $T_j=0^\circ C - 125^\circ C$, $C_1=0.33\mu F$, $C_o=0.1\mu F$, unless otherwise specified)(Note 1)

PARAMETER	SYMBOL	TEST CONDITIONS	MIN	TYP	MAX	UNIT
Output Voltage	V_o	$T_j=25^\circ C$, $I_o=5mA - 1.0A$	17.28	18.0	18.72	V
		$V_I=21V$ to $33V$, $I_o=5mA - 1.0A$, $P_D \leq 15W$	17.10		18.90	V
Load Regulation	ΔV_o	$T_j=25^\circ C$, $I_o=5mA - 1.0A$			360	mV
		$T_j=25^\circ C$, $I_o=0.25A - 0.75A$			180	mV
Line regulation	ΔV_o	$V_I=21V$ to $33V$, $T_j=25^\circ C$			360	mV
		$V_I=21V$ to $33V$, $T_j=25^\circ C$, $I_o=1.0A$			180	mV
Quiescent Current	I_q	$T_j=25^\circ C$, $I_o \leq 1.0A$			8.0	mA
Quiescent Current Change	ΔI_q	$V_I=21.5V$ to $33V$			1.0	mA
		$I_o=5mA - 1.0A$			0.5	mA
Output Noise Voltage	V_N	$10Hz \leq f \leq 100kHz$		110		μV
Ripple Rejection	RR	$V_I=22V - 32V$, $f=120Hz$, $T_j=25^\circ C$	53	69		dB
Peak Output Current	I_{PK}	$T_j=25^\circ C$		1.8		A
Short-Circuit Current	I_{SC}	$V_I=35V$, $T_j=25^\circ C$		200		mA
Dropout Voltage	V_d	$T_j=25^\circ C$		2.0		V

LR7824 ELECTRICAL CHARACTERISTICS

($V_I=33V$, $I_o=0.5A$, $T_j=0^\circ C - 125^\circ C$, $C_1=0.33\mu F$, $C_o=0.1\mu F$, unless otherwise specified)(Note 1)

PARAMETER	SYMBOL	TEST CONDITIONS	MIN	TYP	MAX	UNIT
Output Voltage	V_o	$T_j=25^\circ C$, $I_o=5mA - 1.0A$	23.04	24.0	24.96	V
		$V_I=27V$ to $38V$, $I_o=5mA - 1.0A$, $P_D \leq 15W$	22.80		25.20	V
Load Regulation	ΔV_o	$T_j=25^\circ C$, $I_o=5mA - 1.0A$			360	mV
		$T_j=25^\circ C$, $I_o=0.25A - 0.75A$			240	mV
Line regulation	ΔV_o	$V_I=27V$ to $38V$, $T_j=25^\circ C$			360	mV
		$V_I=27V$ to $38V$, $T_j=25^\circ C$, $I_o=1.0A$			240	mV
Quiescent Current	I_q	$T_j=25^\circ C$, $I_o \leq 1.0A$			8.0	mA
Quiescent Current Change	ΔI_q	$V_I=28V$ to $38V$			1.0	mA
		$I_o=5mA - 1.0A$			0.5	mA
Output Noise Voltage	V_N	$10Hz \leq f \leq 100kHz$		170		μV
Ripple Rejection	RR	$V_I=28V - 38V$, $f=120Hz$, $T_j=25^\circ C$	50	66		dB
Peak Output Current	I_{PK}	$T_j=25^\circ C$		1.8		A
Short-Circuit Current	I_{SC}	$V_I=35V$, $T_j=25^\circ C$		250		mA
Dropout Voltage	V_d	$T_j=25^\circ C$		2.0		V

Note 1: The Maximum steady state usable output current are dependent on input voltage, heat sinking, lead length of the package and copper pattern of PCB. The data above represents pulse test conditions with junction temperatures specified at the initiation of test.

Note 2: Power dissipation < 0.5W

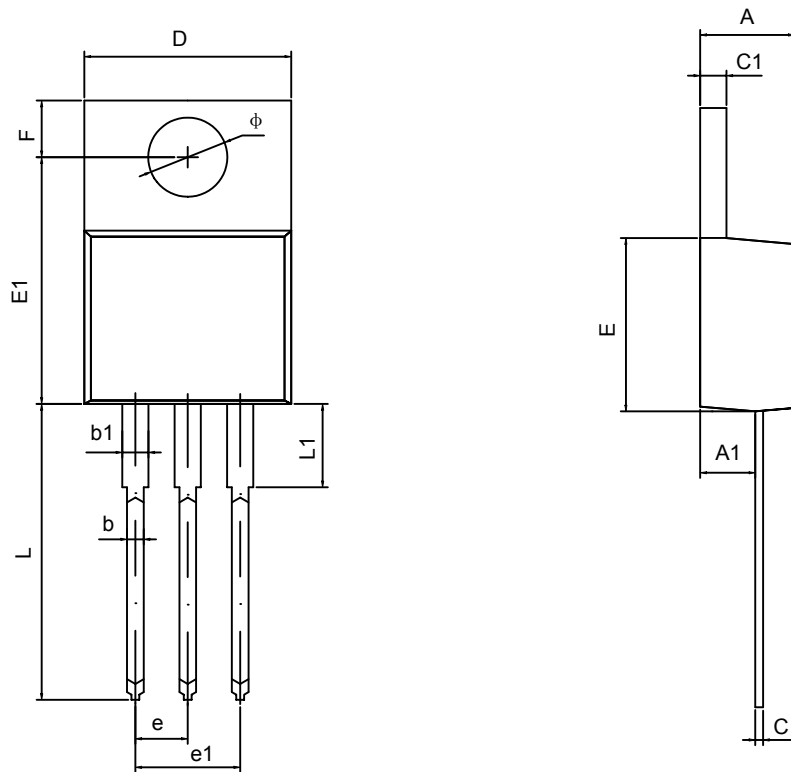
TO-220-3L

Symbol	Dimensions In Millimeters		Dimensions In Inches	
	Min	Max	Min	Max
A	4.470	4.670	0.176	0.184
A1	2.520	2.820	0.099	0.111
b	0.710	0.910	0.028	0.036
b1	1.170	1.370	0.046	0.054
c	0.310	0.530	0.012	0.021
c1	1.168	1.370	0.046	0.054
D	10.010	10.310	0.394	0.406
E	8.500	8.900	0.335	0.350
E1	12.060	12.460	0.475	0.491
e	2.540TYP		0.100TYP	
e1	4.980	5.180	0.196	0.204
F	2.590	2.890	0.102	0.114
L	13.400	13.800	0.528	0.543
L1	3.560	3.960	0.140	0.156
ϕ	3.790	3.890	0.149	0.153

X-ON Electronics

Largest Supplier of Electrical and Electronic Components

Click to view similar products for [Linear Voltage Regulators](#) category:

Click to view products by [Leshan](#) manufacturer:

Other Similar products are found below :

[LV5684PVD-XH](#) [MCDTSA6-2R](#) [L7815ACV-DG](#) [714954EB](#) [ZMR500QFTA](#) [BA033LBSG2-TR](#) [LV5680P-E](#) [L79M05T-E](#) [L78LR05D-MA-E](#) [NCV317MBTG](#) [NTE7227](#) [MP2018GZD-33-P](#) [MP2018GZD-5-P](#) [LV5680NPVC-XH](#) [LT1054CN8](#) [ZTS6538SE](#) [UA78L09CLP](#) [UA78L09CLPR](#) [CAT6221-PPTD-GT3](#) [MC78M09CDTRK](#) [NCV51190MNTAG](#) [78M05](#) [HT7150-1](#) [UM1540DB-18](#) [XC6234H281VR-G](#) [WL2834CA-6/TR](#) [TPL730F33-5TR](#) [TLS850F1TA](#) [V50](#) [TPS549B22RVFR](#) [UM1540DB-33](#) [WL9200P3-50B](#) [WL9100P3-33B](#) [WL9005D4-33](#) [XC6219B152MR](#) [WL2855K33-3/TR](#) [PJ54BM33SE](#) [PJ9500M25SA](#) [MD7218E33PC1](#) [H7533-2PR](#) [SK7812AU](#) [SD1A30](#) [78L33](#) [TP78L33T3](#) [L78L33ACUTR](#) [SK6513ST3A-50](#) [SK6054D4-09](#) [SK6054D4-18](#) [SK6054D4-11](#) [SK6054D4-10](#) [LM79L12F](#)