

## LR7800 Series 3-Terminal 1A Positive Voltage Regulators

### DESCRIPTION

The LRC LR78XX family is monolithic fixed voltage regulator integrated circuit. They are suitable for applications that required supply current up to 1 A.

### FEATURES

- \*Output current up to 1A
- \*Fixed output voltage of 5V, 6V, 7V, 8V,9V,10V, 12V, 15V ,18V and 24V available
- \*Thermal overload shutdown protection
- \*Short circuit current limiting

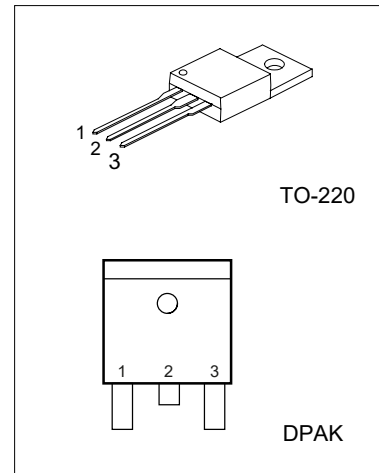

1: Input 2: GND 3: Output

### ORDERING INFORMATION

- \*LR78XX: TO220
- LR78XXD: TO252 (DPAK)

### ABSOLUTE MAXIMUM RATINGS (Operating temperature range applies unless otherwise specified)

PARAMETER	SYMBOL	RATING	UNIT
Input voltage (for $V_o=5\sim 18V$ ) (for $V_o=24V$ )	$V_i$	35	V
		40	V
Output Current	$I_o$	1	A
Power Dissipation	$P_D$	Internally Limited	W
Thermal Resistance Junction-Air	$R_{\theta JA}$ (TO220)	65	$^{\circ}C/W$
Thermal Resistance Junction-Air	$R_{\theta JA}$ (DPAK)	90	$^{\circ}C/W$
Operating Junction Temperature Range	$T_{opr}$	0 ~ +150	$^{\circ}C$
Operating Ambient Temperature	$T_A$	-40 ~ +125	$^{\circ}C$
Storage Temperature Range	$T_{stg}$	-55 ~ +150	$^{\circ}C$

ESD: HBM 2000V

### APPLICATION CIRCUIT

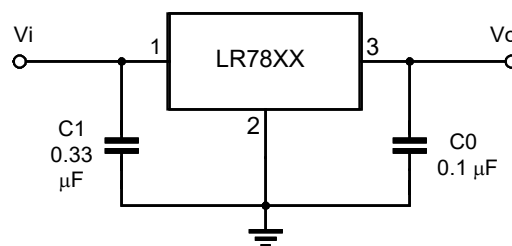

Note 1: To specify an output voltage, substitute voltage value for "XX".

Note 2: Bypass capacitors are recommended for optimum stability and transient response and should be located as close as possible to the regulators.

## LR7800 Series 3-Terminal 1A Positive Voltage Regulators

### LR7805 ELECTRICAL CHARACTERISTICS

( $V_I=10V$ ,  $I_o=0.5A$ ,  $T_j=0^\circ C - 125^\circ C$ ,  $C_1=0.33\mu F$ ,  $C_o=0.1\mu F$ , unless otherwise specified)(Note 1)

PARAMETER	SYMBOL	TEST CONDITIONS	MIN	TYP	MAX	UNIT
Output Voltage	$V_o$	$T_j=25^\circ C$ , $I_o=5mA - 1.0A$	4.80	5.0	5.20	V
		$V_I=7.5V$ to $20V$ , $I_o=5mA - 1.0A$ , $P_D \leq 15W$	4.75		5.25	V
Load Regulation	$\Delta V_o$	$T_j=25^\circ C$ , $I_o=5mA - 1.0A$		9	100	mV
		$T_j=25^\circ C$ , $I_o=0.25A - 0.75A$		4	50	mV
Line regulation	$\Delta V_o$	$V_I=7V$ to $25V$ , $T_j=25^\circ C$			100	mV
		$V_I=8V$ to $12V$ , $T_j=25^\circ C$			50	mV
Quiescent Current	$I_q$	$T_j=25^\circ C$ , $I_o \leq 1.0A$			8.0	mA
Quiescent Current Change	$\Delta I_q$	$V_I=7.5V$ to $20V$			1.3	mA
		$I_o=5mA - 1.0A$			0.5	mA
Output Noise Voltage	$V_N$	$10Hz \leq f \leq 100kHz$		42		$\mu V$
Ripple Rejection	RR	$V_I=8V - 18V$ , $f=120Hz$ , $T_j=25^\circ C$	62	73		dB
Peak Output Current	$I_{PK}$	$T_j=25^\circ C$		1.8		A
Short-Circuit Current	$I_{SC}$	$V_I=35V$ , $T_j=25^\circ C$		250		mA
Dropout Voltage	$V_d$	$T_j=25^\circ C$		2.0		V

### LR7806 ELECTRICAL CHARACTERISTICS

( $V_I=11V$ ,  $I_o=0.5A$ ,  $T_j=0^\circ C - 125^\circ C$ ,  $C_1=0.33\mu F$ ,  $C_o=0.1\mu F$ , unless otherwise specified)(Note 1)

PARAMETER	SYMBOL	TEST CONDITIONS	MIN	TYP	MAX	UNIT
Output Voltage	$V_o$	$T_j=25^\circ C$ , $I_o=5mA - 1.0A$	5.75	6.0	6.25	V
		$V_I=8.5V$ to $21V$ , $I_o=5mA - 1.0A$ , $P_D \leq 15W$	5.70		6.30	V
Load Regulation	$\Delta V_o$	$T_j=25^\circ C$ , $I_o=5mA - 1.0A$			120	mV
		$T_j=25^\circ C$ , $I_o=0.25A - 0.75A$			60	mV
Line regulation	$\Delta V_o$	$V_I=8V$ to $25V$ , $T_j=25^\circ C$			120	mV
		$V_I=8.5V$ to $21V$ , $T_j=25^\circ C$ , $I_o=1.0A$			60	mV
Quiescent Current	$I_q$	$T_j=25^\circ C$ , $I_o \leq 1.0A$			8.0	mA
Quiescent Current Change	$\Delta I_q$	$V_I=8.5V$ to $21V$			1.3	mA
		$I_o=5mA - 1.0A$			0.5	mA
Output Noise Voltage	$V_N$	$10Hz \leq f \leq 100kHz$		45		$\mu V$
Ripple Rejection	RR	$V_I=9V - 19V$ , $f=120Hz$ , $T_j=25^\circ C$	59	75		dB
Peak Output Current	$I_{PK}$	$T_j=25^\circ C$		1.8		A
Short-Circuit Current	$I_{SC}$	$V_I=35V$ , $T_j=25^\circ C$		550		mA
Dropout Voltage	$V_d$	$T_j=25^\circ C$		2.0		V

## LR7800 Series 3-Terminal 1A Positive Voltage Regulators

### LR7807 ELECTRICAL CHARACTERISTICS

( $V_I=13V$ ,  $I_o=0.5A$ ,  $T_j=0^\circ C - 125^\circ C$ ,  $C_1=0.33\mu F$ ,  $C_o=0.1\mu F$ , unless otherwise specified)(Note 1)

PARAMETER	SYMBOL	TEST CONDITIONS	MIN	TYP	MAX	UNIT
Output Voltage	$V_o$	$T_j=25^\circ C$ , $I_o=5mA - 1.0A$	6.72	7.0	7.28	V
		$V_I=9.5V$ to $22V$ , $I_o=5mA - 1.0A$ , $P_D \leq 15W$	6.65		7.35	V
Load Regulation	$\Delta V_o$	$T_j=25^\circ C$ , $I_o=5mA - 1.0A$			120	mV
		$T_j=25^\circ C$ , $I_o=0.25A - 0.75A$			60	mV
Line regulation	$\Delta V_o$	$V_I=9V$ to $25V$ , $T_j=25^\circ C$			120	mV
		$V_I=9.5V$ to $22V$ , $T_j=25^\circ C$ , $I_o=1.0A$			60	mV
Quiescent Current	$I_q$	$T_j=25^\circ C$ , $I_o \leq 1.0A$			8.0	mA
Quiescent Current Change	$\Delta I_q$	$V_I=9.5V$ to $22V$			1.0	mA
		$I_o=5mA - 1.0A$			0.5	mA
Output Noise Voltage	$V_N$	$10Hz \leq f \leq 100kHz$		50		$\mu V$
Ripple Rejection	RR	$V_I=10V - 20V$ , $f=120Hz$ , $T_j=25^\circ C$	59	75		dB
Peak Output Current	$I_{PK}$	$T_j=25^\circ C$		1.7		A
Short-Circuit Current	$I_{SC}$	$V_I=35V$ , $T_j=25^\circ C$		250		mA
Dropout Voltage	$V_d$	$T_j=25^\circ C$		2.0		V

### LR7808 ELECTRICAL CHARACTERISTICS

( $V_I=14V$ ,  $I_o=0.5A$ ,  $T_j=0^\circ C - 125^\circ C$ ,  $C_1=0.33\mu F$ ,  $C_o=0.1\mu F$ , unless otherwise specified)(Note 1)

PARAMETER	SYMBOL	TEST CONDITIONS	MIN	TYP	MAX	UNIT
Output Voltage	$V_o$	$T_j=25^\circ C$ , $I_o=5mA - 1.0A$	7.68	8.0	8.32	V
		$V_I=10.5V$ to $23V$ , $I_o=5mA - 1.0A$ , $P_D \leq 15W$	7.60		8.40	V
Load Regulation	$\Delta V_o$	$T_j=25^\circ C$ , $I_o=5mA - 1.0A$			160	mV
		$T_j=25^\circ C$ , $I_o=0.25A - 0.75A$			80	mV
Line regulation	$\Delta V_o$	$V_I=10.5V$ to $25V$ , $T_j=25^\circ C$			160	mV
		$V_I=10.5V$ to $23V$ , $T_j=25^\circ C$ , $I_o=1.0A$			80	mV
Quiescent Current	$I_q$	$T_j=25^\circ C$ , $I_o \leq 1.0A$			8.0	mA
Quiescent Current Change	$\Delta I_q$	$V_I=10.5V$ to $23V$			1.0	mA
		$I_o=5mA - 1.0A$			0.5	mA
Output Noise Voltage	$V_N$	$10Hz \leq f \leq 100kHz$		52		$\mu V$
Ripple Rejection	RR	$V_I=11.5V$ to $21.5V$ , $f=120Hz$ , $T_j=25^\circ C$	56	72		dB
Peak Output Current	$I_{PK}$	$T_j=25^\circ C$		1.8		A
Short-Circuit Current	$I_{SC}$	$V_I=35V$ , $T_j=25^\circ C$		450		mA
Dropout Voltage	$V_d$	$T_j=25^\circ C$		2.0		V

## LR7800 Series 3-Terminal 1A Positive Voltage Regulators

### LR7809 ELECTRICAL CHARACTERISTICS

( $V_I=15V$ ,  $I_o=0.5A$ ,  $T_j=0^\circ C - 125^\circ C$ ,  $C_1=0.33\mu F$ ,  $C_o=0.1\mu F$ , unless otherwise specified)(Note 1)

PARAMETER	SYMBOL	TEST CONDITIONS	MIN	TYP	MAX	UNIT
Output Voltage	$V_o$	$T_j=25^\circ C$ , $I_o=5mA - 1.0A$	8.64	9.0	9.36	V
		$V_I=11.5V$ to $24V$ , $I_o=5mA - 1.0A$ , $P_D \leq 15W$	8.55		9.45	V
Load Regulation	$\Delta V_o$	$T_j=25^\circ C$ , $I_o=5mA - 1.0A$			180	mV
		$T_j=25^\circ C$ , $I_o=0.25A - 0.75A$			90	mV
Line regulation	$\Delta V_o$	$V_I=11.5V$ to $25V$ , $T_j=25^\circ C$			180	mV
		$V_I=11.5V$ to $24V$ , $T_j=25^\circ C$ , $I_o=1.0A$			90	mV
Quiescent Current	$I_q$	$T_j=25^\circ C$ , $I_o \leq 1.0A$			8.0	mA
Quiescent Current Change	$\Delta I_q$	$V_I=11.5V$ to $24V$			1.0	mA
		$I_o=5mA - 1.0A$			0.5	mA
Output Noise Voltage	$V_N$	$10Hz \leq f \leq 100kHz$		58		$\mu V$
Ripple Rejection	RR	$V_I=12.5V$ to $22.5V$ , $f=120Hz$ , $T_j=25^\circ C$	56	70		dB
Peak Output Current	$I_{PK}$	$T_j=25^\circ C$		1.8		A
Short-Circuit Current	$I_{SC}$	$V_I=35V$ , $T_j=25^\circ C$		400		mA
Dropout Voltage	$V_d$	$T_j=25^\circ C$		2.0		V

### LR7810 ELECTRICAL CHARACTERISTICS

( $V_I=16V$ ,  $I_o=0.5A$ ,  $T_j=0^\circ C - 125^\circ C$ ,  $C_1=0.33\mu F$ ,  $C_o=0.1\mu F$ , unless otherwise specified)(Note 1)

PARAMETER	SYMBOL	TEST CONDITIONS	MIN	TYP	MAX	UNIT
Output Voltage	$V_o$	$T_j=25^\circ C$ , $I_o=5mA - 1.0A$	9.60	10.0	10.40	V
		$V_I=12.5V$ to $25V$ , $I_o=5mA - 1.0A$ , $P_D \leq 15W$	9.50		10.50	V
Load Regulation	$\Delta V_o$	$T_j=25^\circ C$ , $I_o=5mA - 1.0A$			200	mV
		$T_j=25^\circ C$ , $I_o=0.25A - 0.75A$			100	mV
Line regulation	$\Delta V_o$	$V_I=13V$ to $25V$ , $T_j=25^\circ C$			200	mV
		$V_I=13V$ to $25V$ , $T_j=25^\circ C$ , $I_o=1.0A$			100	mV
Quiescent Current	$I_q$	$T_j=25^\circ C$ , $I_o \leq 1.0A$			8.0	mA
Quiescent Current Change	$\Delta I_q$	$V_I=12.6V$ to $25V$			1.0	mA
		$I_o=5mA - 1.0A$			0.5	mA
Output Noise Voltage	$V_N$	$10Hz \leq f \leq 100kHz$		58		$\mu V$
Ripple Rejection	RR	$V_I=13V - 23V$ , $f=120Hz$ , $T_j=25^\circ C$	56	71		dB
Peak Output Current	$I_{PK}$	$T_j=25^\circ C$		1.8		A
Short-Circuit Current	$I_{SC}$	$V_I=35V$ , $T_j=25^\circ C$		400		mA
Dropout Voltage	$V_d$	$T_j=25^\circ C$		2.0		V

## LR7800 Series 3-Terminal 1A Positive Voltage Regulators

### LR7812 ELECTRICAL CHARACTERISTICS

( $V_I=19V$ ,  $I_o=0.5A$ ,  $T_j=0^{\circ}C - 125^{\circ}C$ ,  $C_1=0.33\mu F$ ,  $C_o=0.1\mu F$ , unless otherwise specified )(Note 1)

PARAMETER	SYMBOL	TEST CONDITIONS	MIN	TYP	MAX	UNIT
Output Voltage	$V_o$	$T_j=25^{\circ}C$ , $I_o=5mA - 1.0A$	11.5	12.0	12.5	V
		$V_I = 14.5V$ to $27V$ , $I_o=5mA - 1.0A$ , $P_d \leq 15W$	11.4		12.60	V
Load Regulation	$\Delta V_o$	$T_j=25^{\circ}C$ , $I_o=5mA - 1.0A$			240	mV
		$T_j=25^{\circ}C$ , $I_o=0.25A - 0.75A$			120	mV
Line regulation	$\Delta V_o$	$V_I = 14.5V$ to $30V$ , $T_j=25^{\circ}C$			240	mV
		$V_I = 14.6V$ to $27V$ , $T_j=25^{\circ}C$ , $I_o=1.0A$			120	mV
Quiescent Current	$I_q$	$T_j=25^{\circ}C$ , $I_o \leq 1.0A$			8.0	mA
Quiescent Current Change	$\Delta I_q$	$V_I = 14.5V$ to $30V$			1.0	mA
		$I_o=5mA - 1.0A$			0.5	mA
Output Noise Voltage	$V_N$	$10Hz \leq f \leq 100kHz$		76		$\mu V$
Ripple Rejection	RR	$V_I = 15V - 25V$ , $f=120Hz$ , $T_j=25^{\circ}C$	55	71		dB
Peak Output Current	$I_{PK}$	$T_j=25^{\circ}C$		1.8		A
Short-Circuit Current	$I_{SC}$	$V_I=35V$ , $T_j=25^{\circ}C$		230		mA
Dropout Voltage	$V_d$	$T_j=25^{\circ}C$		2.0		V

### LR7815 ELECTRICAL CHARACTERISTICS

( $V_I=23V$ ,  $I_o=0.5A$ ,  $T_j=0^{\circ}C - 125^{\circ}C$ ,  $C_1=0.33\mu F$ ,  $C_o=0.1\mu F$ , unless otherwise specified )(Note 1)

PARAMETER	SYMBOL	TEST CONDITIONS	MIN	TYP	MAX	UNIT
Output Voltage	$V_o$	$T_j=25^{\circ}C$ , $I_o=5mA - 1.0A$	14.40	15.0	15.60	V
		$V_I = 17.5V$ to $30V$ , $I_o=5mA - 1.0A$ , $P_d \leq 15W$	14.25		15.75	V
Load Regulation	$\Delta V_o$	$T_j=25^{\circ}C$ , $I_o=5mA - 1.0A$			300	mV
		$T_j=25^{\circ}C$ , $I_o=0.25A - 0.75A$			150	mV
Line regulation	$\Delta V_o$	$V_I = 18.5V$ to $30V$ , $T_j=25^{\circ}C$			300	mV
		$V_I = 17.7V$ to $30V$ , $T_j=25^{\circ}C$ , $I_o = 1.0A$			150	mV
Quiescent Current	$I_q$	$T_j=25^{\circ}C$ , $I_o \leq 1.0A$			8.0	mA
Quiescent Current Change	$\Delta I_q$	$V_I = 17.5V$ to $30V$			1.0	mA
		$I_o=5mA - 1.0A$			0.5	mA
Output Noise Voltage	$V_N$	$10Hz \leq f \leq 100kHz$		90		$\mu V$
Ripple Rejection	RR	$V_I = 18.5V$ to $28.5V$ $f=120Hz$ , $T_j=25^{\circ}C$	54	70		dB
Peak Output Current	$I_{PK}$	$T_j=25^{\circ}C$		1.8		A
Short-Circuit Current	$I_{SC}$	$V_I=35V$ , $T_j=25^{\circ}C$		230		mA
Dropout Voltage	$V_d$	$T_j=25^{\circ}C$		2.0		V

## LR7800 Series 3-Terminal 1A Positive Voltage Regulators

### LR7818 ELECTRICAL CHARACTERISTICS

( $V_I=27V$ ,  $I_o=0.5A$ ,  $T_j=0^{\circ}C - 125^{\circ}C$ ,  $C_1=0.33\mu F$ ,  $C_o=0.1\mu F$ , unless otherwise specified)(Note 1)

PARAMETER	SYMBOL	TEST CONDITIONS	MIN	TYP	MAX	UNIT
Output Voltage	$V_o$	$T_j=25^{\circ}C$ , $I_o=5mA - 1.0A$	17.28	18.0	18.72	V
		$V_I=21V$ to $33V$ , $I_o=5mA - 1.0A$ , $P_D \leq 15W$	17.10		18.90	V
Load Regulation	$\Delta V_o$	$T_j=25^{\circ}C$ , $I_o=5mA - 1.0A$			360	mV
		$T_j=25^{\circ}C$ , $I_o=0.25A - 0.75A$			180	mV
Line regulation	$\Delta V_o$	$V_I=21V$ to $33V$ , $T_j=25^{\circ}C$			360	mV
		$V_I=21V$ to $33V$ , $T_j=25^{\circ}C$ , $I_o=1.0A$			180	mV
Quiescent Current	$I_q$	$T_j=25^{\circ}C$ , $I_o \leq 1.0A$			8.0	mA
Quiescent Current Change	$\Delta I_q$	$V_I=21.5V$ to $33V$			1.0	mA
		$I_o=5mA - 1.0A$			0.5	mA
Output Noise Voltage	$V_N$	$10Hz \leq f \leq 100kHz$		110		$\mu V$
Ripple Rejection	RR	$V_I=22V - 32V$ , $f=120Hz$ , $T_j=25^{\circ}C$	53	69		dB
Peak Output Current	$I_{PK}$	$T_j=25^{\circ}C$		1.8		A
Short-Circuit Current	$I_{SC}$	$V_I=35V$ , $T_j=25^{\circ}C$		200		mA
Dropout Voltage	$V_d$	$T_j=25^{\circ}C$		2.0		V

### LR7824 ELECTRICAL CHARACTERISTICS

( $V_I=33V$ ,  $I_o=0.5A$ ,  $T_j=0^{\circ}C - 125^{\circ}C$ ,  $C_1=0.33\mu F$ ,  $C_o=0.1\mu F$ , unless otherwise specified)(Note 1)

PARAMETER	SYMBOL	TEST CONDITIONS	MIN	TYP	MAX	UNIT
Output Voltage	$V_o$	$T_j=25^{\circ}C$ , $I_o=5mA - 1.0A$	23.04	24.0	24.96	V
		$V_I=27V$ to $38V$ , $I_o=5mA - 1.0A$ , $P_D \leq 15W$	22.80		25.20	V
Load Regulation	$\Delta V_o$	$T_j=25^{\circ}C$ , $I_o=5mA - 1.0A$			360	mV
		$T_j=25^{\circ}C$ , $I_o=0.25A - 0.75A$			240	mV
Line regulation	$\Delta V_o$	$V_I=27V$ to $38V$ , $T_j=25^{\circ}C$			360	mV
		$V_I=27V$ to $38V$ , $T_j=25^{\circ}C$ , $I_o=1.0A$			240	mV
Quiescent Current	$I_q$	$T_j=25^{\circ}C$ , $I_o \leq 1.0A$			8.0	mA
Quiescent Current Change	$\Delta I_q$	$V_I=28V$ to $38V$			1.0	mA
		$I_o=5mA - 1.0A$			0.5	mA
Output Noise Voltage	$V_N$	$10Hz \leq f \leq 100kHz$		170		$\mu V$
Ripple Rejection	RR	$V_I=28V - 38V$ , $f=120Hz$ , $T_j=25^{\circ}C$	50	66		dB
Peak Output Current	$I_{PK}$	$T_j=25^{\circ}C$		1.8		A
Short-Circuit Current	$I_{SC}$	$V_I=35V$ , $T_j=25^{\circ}C$		250		mA
Dropout Voltage	$V_d$	$T_j=25^{\circ}C$		2.0		V

Note 1: The Maximum steady state usable output current are dependent on input voltage, heat sinking, lead length of the package and copper pattern of PCB. The data above represents pulse test conditions with junction temperatures specified at the initiation of test.

Note 2: Power dissipation < 0.5W

## TO-220

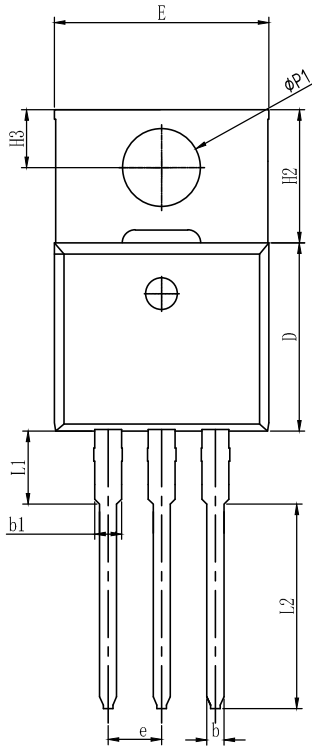

TOP VIEW

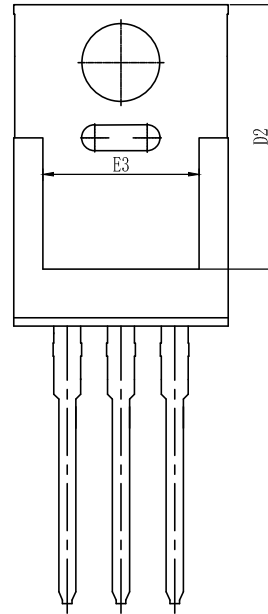
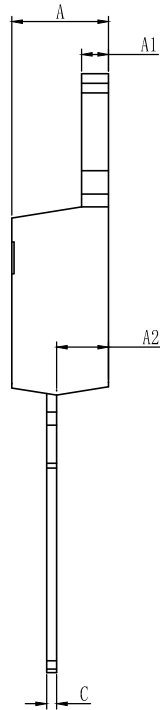

BOTTOM VIEW

SYMBOL	MM		
	MIN	NOM	MAX
A	4.42	4.57	4.72
A1	1.20	1.30	1.40
A2	2.35	2.45	2.55
b	0.73	0.83	0.93
b1	1.20	1.30	1.40
c	0.41	0.48	0.58
D	8.70	8.90	9.10
D2	12.20	12.50	12.80
E	9.85	10.15	10.45
E3	7.10	7.40	7.70
e	2.54BSC		
H2	6.10	6.30	6.50
H3	2.54	2.74	2.94
L1	3.16	3.46	3.76
L2	9.36	9.66	9.96
ØP1	3.48	3.68	3.88

### GENERAL NOTES

1. Top package surface finish Max Ra1.2±0.2um
2. Bottom package surface finish MAX Ra02um
3. Protrusion or Gate Burrs shall not exceed 0.05mm per side.
4. Off center Max0.05mm; Mismatch Max 0.05mm.

### MARKING

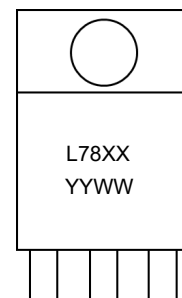

TO-220

Ordering Information		
Type	Ship Min Package	MOQ
TO-220	50 Units/ Tube	1000

## TO252 (DPAK)

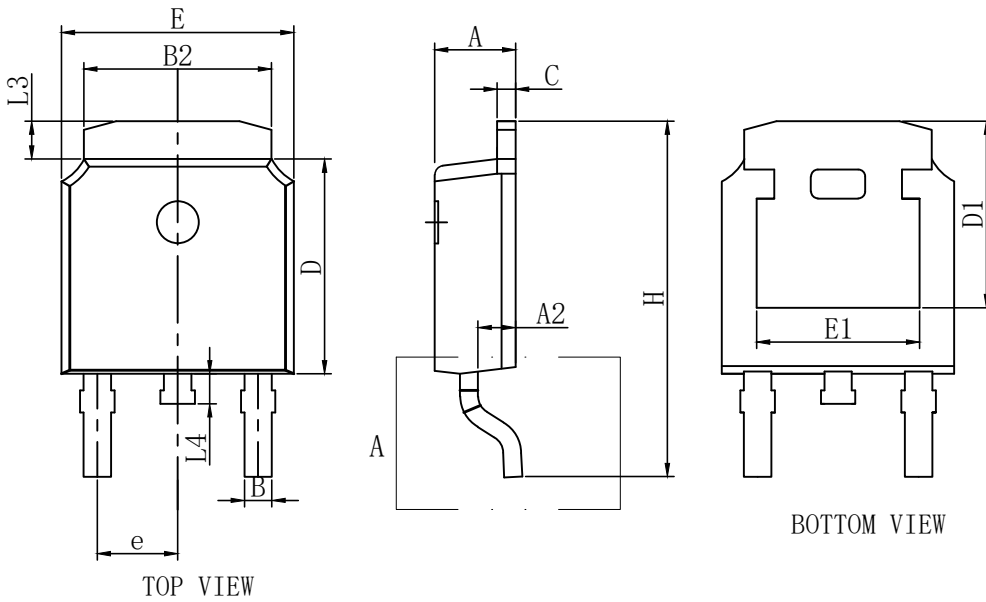

SYMBOL	mm		
	MIN	NOM	MAX
A	2.15	2.30	2.45
A1	0		0.20
A2	0.9	1.07	1.17
B	0.68	0.78	0.88
B2	5.20	5.33	5.46
D	5.90	6.10	6.30
D1	5.30REF		
E	6.40	6.60	6.80
E1	4.63	4.83	5.03
e	2.286BSC		
H	9.8	10.10	10.4
L	1.30	1.50	1.70
L1	2.90REF		
L2	0.51BSC		
L3	0.88	1.08	1.28
L4	0.55	0.80	1.05

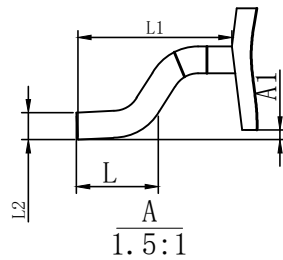

### MARKING

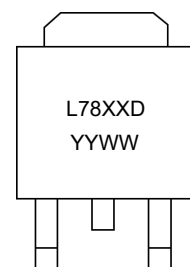

DPAK

Ordering Information		
Type	Ship Min Package	MOQ
DPAK	2500 Units/ Reel	5000



**DISCLAIMER**

- Curve guarantee in the specification. The curve of test items with electric parameter is used as quality guarantee. The curve of test items without electric parameter is used as reference only.
- Before you use our Products for new Project, you are requested to carefully read this document and fully understand its contents. LRC shall not be in any way responsible or liable for failure, malfunction or accident arising from the use of any LRC's Products against warning, caution or note contained in this document.
- All information contained in this document is current as of the issuing date and subject to change without any prior notice. Before purchasing or using LRC's Products, please confirm the latest information with a LRC sales representative.

## X-ON Electronics

Largest Supplier of Electrical and Electronic Components

*Click to view similar products for [Linear Voltage Regulators](#) category:*

*Click to view products by [Leshan](#) manufacturer:*

Other Similar products are found below :

[LV5684PVD-XH](#) [MCDTSA6-2R](#) [L7815ACV-DG](#) [LV56801P-E](#) [UA7805CKC](#) [714954EB](#) [ZMR500QFTA](#) [BA033LBSG2-TR](#)  
[NCV78M05ABDTRKG](#) [LV5680P-E](#) [L79M05T-E](#) [L78LR05D-MA-E](#) [NCV317MBTG](#) [NTE7227](#) [MP2018GZD-33-P](#) [MP2018GZD-5-P](#)  
[LV5680NPVC-XH](#) [ZTS6538SE](#) [UA78L09CLP](#) [UA78L09CLPR](#) [CAT6221-PPTD-GT3](#) [MC78M09CDTRK](#) [NCV51190MNTAG](#)  
[BL1118CS8TR1833](#) [BL8077CKETR33](#) [BL9153-33CC3TR](#) [BL9161G-28BADRN](#) [BRCO7530MMC](#) [CJ7815B-TFN-ARG](#) [LM317C](#)  
[GM7333K](#) [GM7350K](#) [XC6206P332MR](#) [HT7533](#) [LM7912S/TR](#) [LT1764S/TR](#) [LM7805T](#) [LM338T](#) [LM1117IMP-3.3/TR](#) [HT1117AM-3.3](#)  
[HT7550S](#) [AMS1117-3.3](#) [HT7150S](#) [78L12](#) [HT7550](#) [HT7533-1](#) [HXY6206I-2.5](#) [HT7133](#) [HT7533S](#) [662K](#)