

Series3-Terminal 0.1A Positive Voltage Regulators

LR78LXX

DESCRIPTION

The LRC LR78LXX family is monolithic fixed voltage regulator integrated circuit. They are suitable for applications that required supply current up to 100mA.

FEATURES

- *Output current up to 100mA
- *Fixed output voltage of 5V, 6V, 8V, 9V, 12V, 15V, 18V and 24V available
- *Thermal overload shutdown protection
- *Short circuit current limiting
- *We declare that material of product compliance with ROHS requirements.

ORDERING INFORMATION

- *LR78Lxx: TO-92
- *LR78LxxU: SOT89

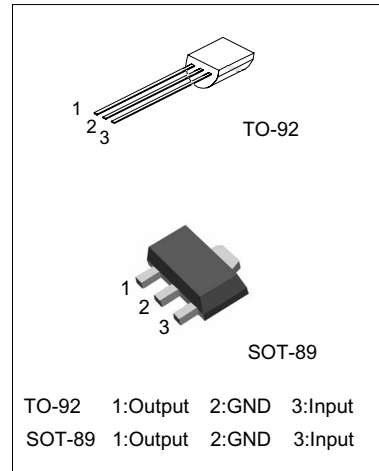

ABSOLUTE MAXIMUM RATINGS

(Operating temperature range applies unless otherwise specified)

PARAMETER	SYMBOL	MIN.	MAX.	UNIT
Input voltage (for $V_o=5\sim 9V$)	V_i		30	V
(for $V_o=12\sim 24V$)	V_i		35	V
Output Current	I_o		100	mA
Power Dissipation	PD			mW
TO-92			625	
SOT-89			350	
Operating Junction Temperature	T_J		+150	°C
Operating Ambient Temperature	T_{OPR}	-55	+125	°C
Storage Temperature Range	T_{STG}	-55	+150	°C

ESD: HBM 2000V

APPLICATION CIRCUIT

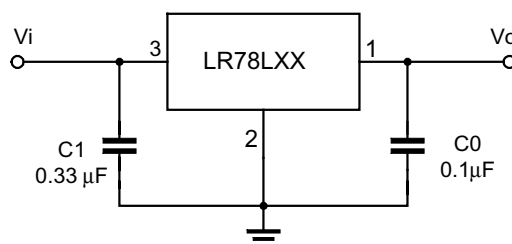

Note 1: To specify an output voltage, substitute voltage value for "XX".

Note 2: Bypass capacitors are recommended for optimum stability and transient response and should be located as close as possible to the regulators.

LR78L00 Series 3-Terminal 0.1A Positive Voltage Regulators

LR78L05 ELECTRICAL CHARACTERISTICS

($V_I=10V$, $I_o=40mA$, $-55^\circ C < T_j < 125^\circ C$, $C_1=0.33\mu F$, $C_o=0.1\mu F$, unless otherwise specified)(Note 1)

PARAMETER	SYMBOL	TEST CONDITIONS	MIN	TYP.	MAX	UNIT
Output Voltage	V_o	$T_j=25^\circ C$	4.80	5.0	5.20	V
		$7V \leq V_I \leq 20V, I_o=1mA-40mA$	4.75		5.25	V
		$7V \leq V_I \leq V_{MAX}, I_o=1mA-70mA$	4.75		5.25	V (note 2)
Load Regulation	V_o	$T_j=25^\circ C, I_o=1mA-100mA$		11	60	mV
		$T_j=25^\circ C, I_o=1mA-40mA$		5.0	30	mV
Line regulation	V_o	$7V \leq V_I \leq 20V, T_j=25^\circ C$		32	150	mV
		$8V \leq V_I \leq 20V, T_j=25^\circ C$		26	100	mV
Quiescent Current	I_q	$V_I=10V, I_o=0mA, T_j=25^\circ C$		3.8	6.1	mA
Quiescent Current Change	ΔI_q	$8V \leq V_I \leq 20V$			1.5	mA
	ΔI_q	$1mA \leq V_I \leq 40mA$			0.1	mA
Output Noise Voltage	V_N	$10Hz \leq f \leq 100kHz$		42		μV
Ripple Rejection	RR	$8V \leq V_I \leq 20V, f=120Hz, T_j=25^\circ C$	41	49		dB
Dropout Voltage	V_d	$T_j=25^\circ C$		1.7		V

LR78L06 ELECTRICAL CHARACTERISTICS

($V_I=12V$, $I_o=40mA$, $-55^\circ C < T_j < 125^\circ C$, $C_1=0.33\mu F$, $C_o=0.1\mu F$, unless otherwise specified)(Note 1)

PARAMETER	SYMBOL	TEST CONDITIONS	MIN	TYP.	MAX	UNIT
Output Voltage	V_o	$T_j=25^\circ C$	5.76	6.0	6.24	V
		$8.5V \leq V_I \leq 20V, I_o=1mA-40mA$	5.70		6.30	V
		$8.5V \leq V_I \leq V_{MAX}, I_o=1mA-70mA$	5.70		6.30	V (note 2)
Load Regulation	V_o	$T_j=25^\circ C, I_o=1mA-100mA$		12.8	80	mV
		$T_j=25^\circ C, I_o=1mA-70mA$		5.8	40	mV
Line regulation	V_o	$8.5V \leq V_I \leq 20V, T_j=25^\circ C$		64	175	mV
		$9V \leq V_I \leq 20V, T_j=25^\circ C$		54	125	mV
Quiescent Current	I_q	$V_I=12V, I_o=0mA, T_j=25^\circ C$		3.9	6.0	mA
Quiescent Current Change	ΔI_q	$9V \leq V_I \leq 20V$			1.5	mA
	ΔI_q	$1mA \leq V_I \leq 40mA$			0.1	mA
Output Noise Voltage	V_N	$10Hz \leq f \leq 100kHz$		49		μV
Ripple Rejection	RR	$10V \leq V_I \leq 20V, f=120Hz, T_j=25^\circ C$	40	46		dB
Dropout Voltage	V_d	$T_j=25^\circ C$		1.7		V

LR78L00 Series 3-Terminal 0.1A Positive Voltage Regulators

LR78L08 ELECTRICAL CHARACTERISTICS

($V_I=14V, I_O=40mA, -55^{\circ}C < T_j < 125^{\circ}C, C_1=0.33\mu F, C_o=0.1\mu F$, unless otherwise specified)(Note 1)

PARAMETER	SYMBOL	TEST CONDITIONS	MIN	TYP	MAX	UNIT
Output Voltage	V_o	$T_j=25^{\circ}C$	7.68	8.0	8.32	V
		$10.5V \leq V_I \leq 23V, I_O=1mA-40mA$	7.60		8.40	V
		$10.5V \leq V_I \leq V_{MAX}, I_O=1mA-70mA$	7.60		8.40	V (note 2)
Load Regulation	V_o	$T_j=25^{\circ}C, I_O=1mA-100mA$		18	80	mV
		$T_j=25^{\circ}C, I_O=1mA-70mA$		10	40	mV
Line regulation	V_o	$10.5V \leq V_I \leq 23V, T_j=25^{\circ}C$		42	175	mV
		$11V \leq V_I \leq 23V, T_j=25^{\circ}$		36	125	mV
Quiescent Current	I_q	$V_{IN}=14V, I_O=0mA, T_j=25^{\circ}C$		4.0	6.0	mA
Quiescent Current Change	ΔI_q	$11V \leq V_I \leq 23V$			1.5	mA
	ΔI_q	$1mA \leq V_I \leq 40mA$			0.1	mA
Output Noise Voltage	V_N	$10Hz \leq f \leq 100kHz$		54		μV
Ripple Rejection	RR	$11V \leq V_I \leq 23V, f=120Hz, T_j=25^{\circ}C$	39	46		dB
Dropout Voltage	V_d	$T_j=25^{\circ}C$		1.7		V

LR78L09 ELECTRICAL CHARACTERISTICS

($V_I=15V, I_O=40mA, -55^{\circ}C < T_j < 125^{\circ}C, C_1=0.33\mu F, C_o=0.1\mu F$, unless otherwise specified)(Note 1)

PARAMETER	SYMBOL	TEST CONDITIONS	MIN	TYP	MAX	UNIT
Output Voltage	V_o	$T_j=25^{\circ}C$	8.64	9.0	9.36	V
		$11.5V \leq V_I \leq 24V, I_O=1mA-40mA$	8.55		9.45	V
		$11.5V \leq V_I \leq V_{MAX}, I_O=1mA-70mA$	8.55		9.45	V (note 2)
Load Regulation	V_o	$T_j=25^{\circ}C, I_O=1mA-100mA$		20	90	mV
		$T_j=25^{\circ}C, I_O=1mA-40mA$		11	45	mV
Line regulation	V_o	$11.5V \leq V_I \leq 24V, T_j=25^{\circ}C$		90	200	mV
		$13V \leq V_I \leq 24V, T_j=25^{\circ}C$		100	150	mV
Quiescent Current	I_q	$V_{IN}=15V, I_O=0mA, T_j=25^{\circ}C$		4.1	6.0	mA
Quiescent Current Change	ΔI_q	$13V \leq V_I \leq 24V$			1.5	mA
	ΔI_q	$1mA \leq V_I \leq 40mA$			0.1	mA
Output Noise Voltage	V_N	$10Hz \leq f \leq 100kHz$		58		μV
Ripple Rejection	RR	$12V \leq V_I \leq 23V, f=120Hz, T_j=25^{\circ}C$	38	44		dB
Dropout Voltage	V_d	$T_j=25^{\circ}C$		1.7		V

LR78L00 Series3-Terminal 0.1A Positive Voltage Regulators

LR78L12 ELECTRICAL CHARACTERISTICS

($V_I=19V, I_o=40mA, -55^{\circ}C < T_j < 125^{\circ}C, C_1=0.33\mu F, C_o=0.1\mu F$, unless otherwise specified)(Note 1)

PARAMETER	SYMBOL	TEST CONDITIONS	MIN	TYP	MAX	UNIT
Output Voltage	V_o	$T_j=25^{\circ}C$	11.5	12.0	12.5	V
		$14.5V \leq V_I \leq 27V, I_o=1mA-40mA$	11.40		12.60	V
		$14.5V \leq V_I \leq V_{MAX}, I_o=1mA-70mA$	11.40		12.60	V (note 2)
Load Regulation	V_o	$T_j=25^{\circ}C, I_o=1mA-100mA$		25	150	mV
		$T_j=25^{\circ}C, I_o=1mA-40mA$		12	75	mV
Line regulation	V_o	$14.5V \leq V_I \leq 27V, T_j=25^{\circ}C$		55	250	mV
		$16V \leq V_I \leq 27V, T_j=25^{\circ}C$		49	200	mV
Quiescent Current	I_q	$V_{IN}=19V, I_o=0mA, T_j=25^{\circ}C$		4.3	6.5	mA
Quiescent Current Change	ΔI_q	$16V \leq V_I \leq 27V$			1.5	mA
	ΔI_q	$1mA \leq V_I \leq 40mA$			0.1	mA
Output Noise Voltage	V_N	$10Hz \leq f \leq 100kHz$		70		μV
Ripple Rejection	RR	$15V \leq V_I \leq 25V, f=120Hz, T_j=25^{\circ}C$	37	42		dB
Dropout Voltage	V_d	$T_j=25^{\circ}C$		1.7		V

LR78L15 ELECTRICAL CHARACTERISTICS

($V_I=23V, I_o=40mA, -55^{\circ}C < T_j < 125^{\circ}C, C_1=0.33\mu F, C_o=0.1\mu F$, unless otherwise specified)(Note 1)

PARAMETER	SYMBOL	TEST CONDITIONS	MIN	TYP	MAX	UNIT
Output Voltage	V_o	$T_j=25^{\circ}C$	14.40	15.0	15.60	V
		$17.5V \leq V_I \leq 30V, I_o=1mA-40mA$	14.25		15.75	V
		$17.5V \leq V_I \leq V_{MAX}, I_o=1mA-70mA$	14.25		15.75	V (note 2)
Load Regulation	V_o	$T_j=25^{\circ}C, I_o=1mA-100mA$		20	150	mV
		$T_j=25^{\circ}C, I_o=1mA-70mA$		25	150	mV
Line regulation	V_o	$17.5V \leq V_I \leq 30V, T_j=25^{\circ}C$		25	150	mV
		$20V \leq V_I \leq 30V, T_j=25^{\circ}C$		15	75	mV
Quiescent Current	I_q	$V_{IN}=23V, I_o=0mA, T_j=25^{\circ}C$		4.6	6.5	mA
Quiescent Current Change	ΔI_q	$20V \leq V_I \leq 30V$			1.5	mA
	ΔI_q	$1mA \leq V_I \leq 40mA$			0.1	mA
Output Noise Voltage	V_N	$10Hz \leq f \leq 100kHz$		82		μV
Ripple Rejection	RR	$18.5V \leq V_I \leq 28.5V, f=120Hz, T_j=25^{\circ}C$	34	39		dB
Dropout Voltage	V_d	$T_j=25^{\circ}C$		1.7		V

LR78L00 Series3-Terminal 0.1A Positive Voltage Regulators

LR78L18 ELECTRICAL CHARACTERISTICS

($V_I=27V, I_o=40mA, -55^{\circ}C < T_j < 125^{\circ}C, C_1=0.33\mu F, C_o=0.1\mu F$, unless otherwise specified)(Note 1)

PARAMETER	SYMBOL	TEST CONDITIONS	MIN	TYP	MAX	UNIT
Output Voltage	V_o	$T_j=25^{\circ}C$	17.30	18.0	18.70	V
		$21V \leq V_I \leq 33V, I_o=1mA-40mA$	17.10		18.90	V
		$21V \leq V_I \leq V_{MAX}, I_o=1mA-70mA$	17.10		18.90	V (note 2)
Load Regulation	V_o	$T_j=25^{\circ}C, I_o=1mA-100mA$		30	180	mV
		$T_j=25^{\circ}C, I_o=1mA-40mA$		19	90	mV
Line regulation	V_o	$21V \leq V_I \leq 33V, T_j=25^{\circ}C$		70	360	mV
		$22V \leq V_I \leq 33V, T_j=25^{\circ}C$		60	300	mV
Quiescent Current	I_q	$V_{IN}=27V, I_o=0mA, T_j=25^{\circ}C$		4.7	6.5	mA
Quiescent Current Change	ΔI_q	$21V \leq V_I \leq 33V$			1.5	mA
	ΔI_q	$1mA \leq V_I \leq 40mA$			0.1	mA
Output Noise Voltage	V_N	$10Hz \leq f \leq 100kHz$		150		μV
Ripple Rejection	RR	$23V \leq V_I \leq 33V, f=120Hz, T_j=25^{\circ}C$	32	36		dB
Dropout Voltage	V_d	$T_j=25^{\circ}C$		1.7		V

LR78L24 ELECTRICAL CHARACTERISTICS

($V_I=33V, I_o=40mA, -55^{\circ}C < T_j < 125^{\circ}C, C_1=0.33\mu F, C_o=0.1\mu F$, unless otherwise specified)(Note 1)

PARAMETER	SYMBOL	TEST CONDITIONS	MIN	TYP	MAX	UNIT
Output Voltage	V_o	$T_j=25^{\circ}C$	23.04	24.0	24.96	V
		$27V \leq V_I \leq 38V, I_o=1mA-40mA$	22.8		25.2	V
		$27V \leq V_I \leq V_{MAX}, I_o=1mA-70mA$	22.8		25.2	V (note 2)
Load Regulation	V_o	$T_j=25^{\circ}C, I_o=1mA-100mA$		40	200	mV
		$T_j=25^{\circ}C, I_o=1mA-40mA$		20	100	mV
Line regulation	V_o	$27V \leq V_I \leq 38V, T_j=25^{\circ}C$		160	360	mV
		$28V \leq V_I \leq 38V, T_j=25^{\circ}C$		150	300	mV
Quiescent Current	I_q	$V_{IN}=33V, I_o=0mA, T_j=25^{\circ}C$		4.7	6.5	mA
Quiescent Current Change	ΔI_q	$27V \leq V_I \leq 38V$			1.5	mA
	ΔI_q	$1mA \leq V_I \leq 40mA$			0.1	mA
Output Noise Voltage	V_N	$10Hz \leq f \leq 100kHz$		200		μV
Ripple Rejection	RR	$27V \leq V_I \leq 38V, f=120Hz, T_j=25^{\circ}C$	34	45		dB
Dropout Voltage	V_d	$T_j=25^{\circ}C$		1.7		V

Note 1: The Maximum steady state usable output current is dependent on input voltage, heat sinking, lead length of the package and copper pattern of PCB. The data above represent pulse test conditions with junction temperatures specified at the initiation of test.

Note 2: Power dissipation < 0.5W

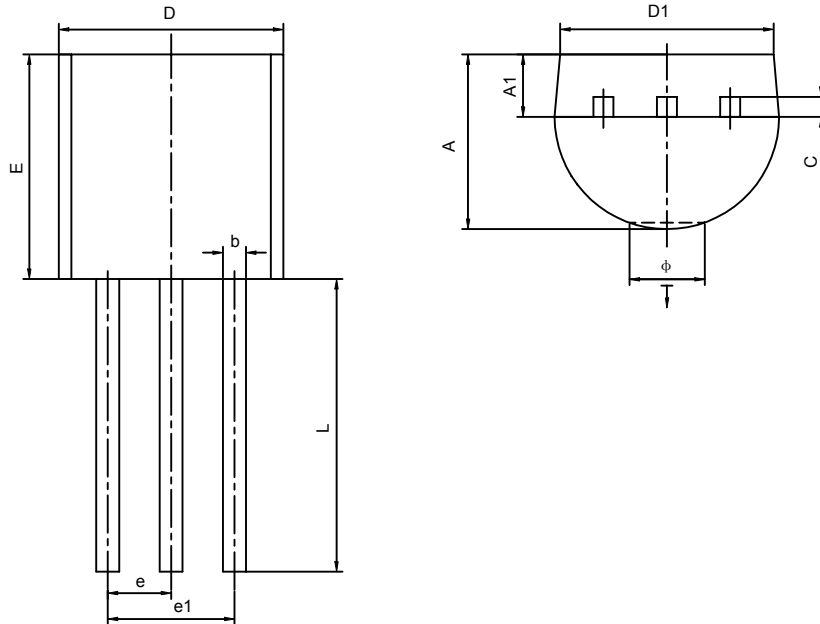
TO-92 PACKAGE OUTLINE DIMENSIONS

Symbol	Dimensions In Millimeters		Dimensions In Inches	
	Min	Max	Min	Max
A	3.300	3.700	0.130	0.146
A1	1.100	1.400	0.043	0.055
b	0.380	0.550	0.015	0.022
c	0.360	0.510	0.014	0.020
D	4.400	4.700	0.173	0.185
D1	3.430		0.135	
E	4.300	4.700	0.169	0.185
e	1.270TYP		0.050TYP	
e1	2.440	2.640	0.096	0.104
L	14.100	14.500	0.555	0.571
Ö		1.600		0.063
↓	0.000	0.380	0.000	0.015

SHIPPING INFORMATION

1. Bag: 1000 Units/ Bag 10 Bag/ Box(240mm*170mm*96mm)
4 Box/ Chest(365mm*270mm*210mm)
2. Tape: 2000 Units/ Box 10 Box/ Chest

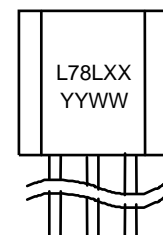
MARKING

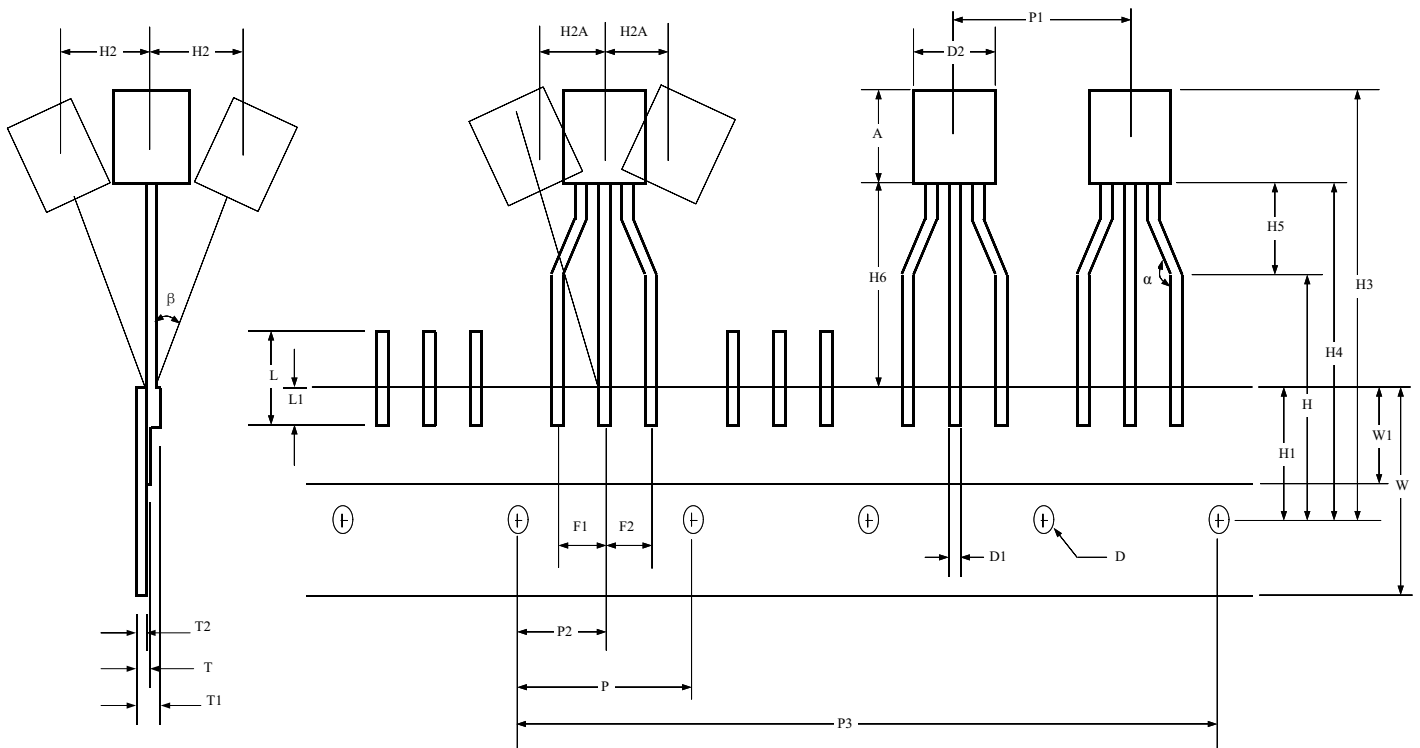
TO-92 TAPPING OUTLINE DIMENSIONS

symbol	mm		inch		symbol	mm		inch	
	min	max	min	max		min	max	min	max
A	4.40	4.80	0.173	0.189	L	-	11.00	-	0.433
D	3.80	4.20	0.150	0.165	L1	2.50	-	0.098	-
D1	0.45	0.55	0.018	0.022	P	12.50	12.90	0.492	0.508
D2	4.40	4.80	0.173	0.189	P1	12.50	12.90	0.492	0.508
F1,F2	2.40	2.90	0.094	0.114	P2	6.31	6.39	0.248	0.252
F1-F2	-0.30	0.30	-0.012	0.012	P3	50.30	51.30	1.980	2.020
H	15.50	16.50	0.610	0.650	T	-	0.55	-	0.022
H1	8.50	9.50	0.335	0.374	T1	-	1.42	-	0.056
H2	-	1.00	-	0.039	T2	0.36	0.55	0.014	0.022
H2A	-	1.00	-	0.039	W	17.50	19.00	0.689	0.748
H3	-	26.00	-	1.024	W1	5.00	7.00	0.197	0.276
H4	-	21.00	-	0.827	W2	-	0.50	-	0.020
H5	3.00	5.00	0.118	0.197	α	145°	155°	145°	155°
H6	9.00	11.00	0.354	0.433	β	-	4°	-	4°

SOT-89-3L PACKAGE OUTLINE DIMENSIONS

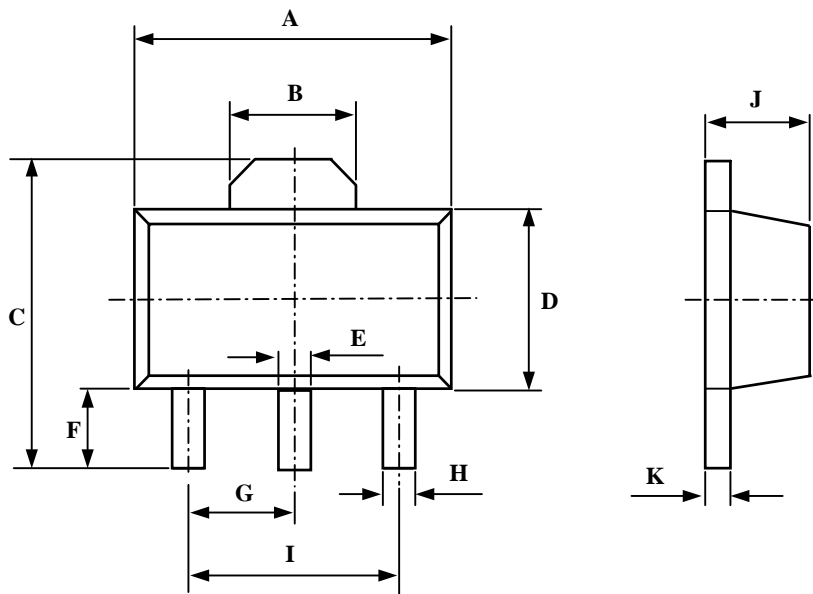

SYMBOL	Dimensions In Mmillimeters		Dimensions In Inches	
	Min	Max	Min	Max
A	4.000	4.600	0.173	0.181
B	1.550 REF		0.061 REF	
C	3.940	4.250	0.155	0.167
D	2.300	2.600	0.091	0.102
E	0.400	0.580	0.016	0.023
F	0.900	1.200	0.035	0.047
G	1.5 TYP		0.06 TYP	
H	0.320	0.520	0.013	0.020
I	3 TYP		0.118 TYP	
J	1.400	1.600	0.055	0.063
K	0.350	0.440	0.014	0.017

SHIPPING INFORMATION

Tape: 2500 Units/ Reel(13 inch)
 2 Reel/ Box(340mm*340mm*50mm)
 6 Box/ Chest(360mm*360mm*315mm)

MARKING

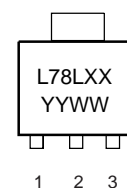

X-ON Electronics

Largest Supplier of Electrical and Electronic Components

Click to view similar products for [Linear Voltage Regulators](#) category:

Click to view products by [Leshan](#) manufacturer:

Other Similar products are found below :

[LV5684PVD-XH](#) [MCDTSA6-2R](#) [L7815ACV-DG](#) [714954EB](#) [ZMR500QFTA](#) [BA033LBSG2-TR](#) [LV5680P-E](#) [L79M05T-E](#) [L78LR05D-MA-E](#) [NCV317MBTG](#) [NTE7227](#) [MP2018GZD-33-P](#) [MP2018GZD-5-P](#) [LV5680NPVC-XH](#) [LT1054CN8](#) [ZTS6538SE](#) [UA78L09CLP](#) [UA78L09CLPR](#) [CAT6221-PPTD-GT3](#) [MC78M09CDTRK](#) [NCV51190MNTAG](#) [78M05](#) [HT7150-1](#) [UM1540DB-18](#) [XC6234H281VR-G](#) [WL2834CA-6/TR](#) [TPL730F33-5TR](#) [TLS850F1TA](#) [V50](#) [TPS549B22RVFR](#) [UM1540DB-33](#) [WL9200P3-50B](#) [WL9100P3-33B](#) [WL9005D4-33](#) [XC6219B152MR](#) [WL2855K33-3/TR](#) [PJ54BM33SE](#) [PJ9500M25SA](#) [MD7218E33PC1](#) [H7533-2PR](#) [SK7812AU](#) [SD1A30](#) [78L33](#) [TP78L33T3](#) [L78L33ACUTR](#) [SK6513ST3A-50](#) [SK6054D4-09](#) [SK6054D4-18](#) [SK6054D4-11](#) [SK6054D4-10](#) [LM79L12F](#)