

3-Terminal 0.5A Positive Voltage Regulator

LR78MXX

Features

- Output Current up to 0.5A
- Output Voltages of 5, 6, 8, 12, 15, 18, 24V
- Thermal Overload Protection
- Short Circuit Protection
- Output Transistor Safe Operating Area (SOA)Protection
- * We declare that material of product compliance with ROHS requirements.

Description

The LR78MXX series of three-terminal positive regulators are available in the TO-220/D-PAK package with several fixed output voltages making it useful in a wide range of applications.

Order Information

LR78MXXD: D-PAK(TO252)

LR78MXX: TO-220

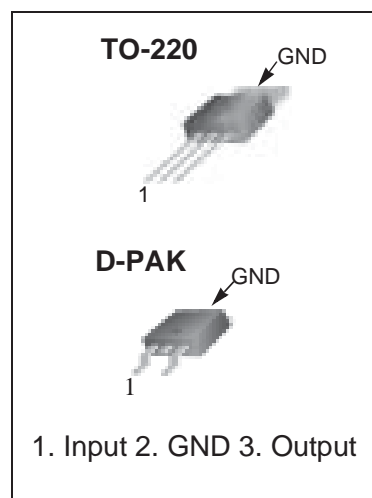

Internal Block Diagram

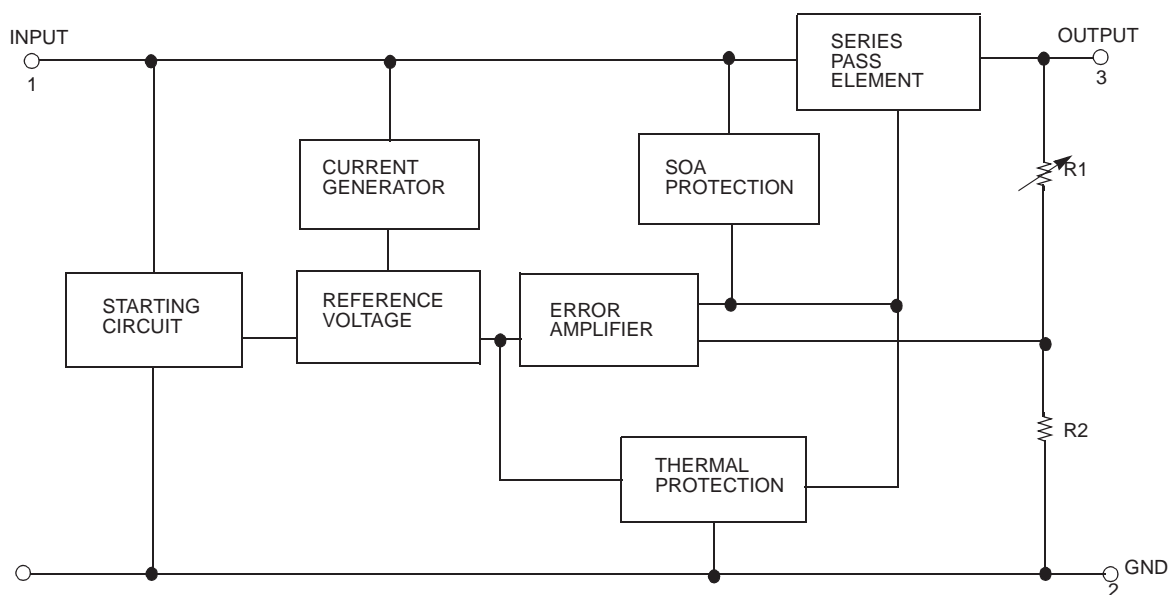

Absolute Maximum Ratings

Parameter	Symbol	Value	Unit
Input Voltage (for $V_O = 5V$ to $18V$) (for $V_O = 24V$)	V_I	35	V
	V_I	40	V
Thermal Resistance Junction-Case (Note1) TO-220 ($T_c = +25^\circ C$)	$R_{\theta JC}$	2.5	$^\circ C/W$
Thermal Resistance Junction-Air (Note1, 2) TO-220 ($T_a = +25^\circ C$) D-PAK ($T_a = +25^\circ C$)	$R_{\theta JA}$	66	$^\circ C/W$
		92	$^\circ C/W$
Operating Junction Temperature Range	T_j	0 ~ +150	$^\circ C$
Operating Ambient Temperature	T_{OPR}	-40 ~ +85	$^\circ C$
Storage Temperature Range	T_{STG}	-65 ~ +150	$^\circ C$

Note:

- Thermal resistance test board
Size: 76.2mm * 114.3mm * 1.6mm(1SOP)
JEDEC standard: JESD51-3, JESD51-7
- Assume no ambient airflow

Electrical Characteristics (LR78M05)

(Refer to the test circuits, $0 \leq T_J \leq +125^\circ C$, $I_O = 350mA$, $V_I = 10V$, unless otherwise specified, $C_I = 0.33\mu F$, $C_O = 0.1\mu F$)

Parameter	Symbol	Conditions	Min.	Typ.	Max.	Unit
Output Voltage	V_O	$T_J = +25^\circ C$	4.8	5	5.2	V
		$I_O = 5mA$ to $350mA$ $V_I = 7V$ to $20V$	4.75	5	5.25	
Line Regulation (Note3)	ΔV_O	$I_O = 200mA$ $T_J = +25^\circ C$	-	-	100	mV
		$V_I = 7V$ to $25V$ $V_I = 8V$ to $25V$			50	
Load Regulation (Note3)	ΔV_O	$I_O = 5mA$ to $0.5A$, $T_J = +25^\circ C$	-	-	100	mV
		$I_O = 5mA$ to $200mA$, $T_J = +25^\circ C$	-	-	50	
Quiescent Current	I_Q	$T_J = +25^\circ C$	-	4.0	6.0	mA
Quiescent Current Change	ΔI_Q	$I_O = 5mA$ to $350mA$	-	-	0.5	mA
		$I_O = 200mA$ $V_I = 8V$ to $25V$	-	-	0.8	
Output Voltage Drift	$\Delta V/\Delta T$	$I_O = 5mA$ $T_J = 0$ to $+125^\circ C$	-	-0.5	-	mV/ $^\circ C$
Output Noise Voltage	V_N	$f = 10Hz$ to $100kHz$	-	40	-	$\mu V/V_O$
Ripple Rejection	RR	$f = 120Hz$, $I_O = 300mA$ $V_I = 8V$ to $18V$, $T_J = +25^\circ C$	-	80	-	dB
Dropout Voltage	V_D	$T_J = +25^\circ C$, $I_O = 500mA$	-	2	-	V
Short Circuit Current	ISC	$T_J = +25^\circ C$, $V_I = 35V$	-	300	-	mA
Peak Current	IPK	$T_J = +25^\circ C$	-	700	-	mA

Note:

- Load and line regulation are specified at constant junction temperature. Change in V_O due to heating effects must be taken into account separately. Pulse testing with low duty is used.

Electrical Characteristics (LR78M06) (Continued)

 (Refer to the test circuits, $0 \leq T_J \leq +125^\circ\text{C}$, $I_O=350\text{mA}$, $V_I=11\text{V}$, unless otherwise specified, $C_I=0.33\mu\text{F}$, $C_O=0.1\mu\text{F}$)

Parameter	Symbol	Conditions	Min.	Typ.	Max.	Unit
Output Voltage	V_O	$T_J = +25^\circ\text{C}$	5.75	6	6.25	V
		$I_O = 5\text{mA to } 350\text{mA}$ $V_I = 8\text{V to } 21\text{V}$	5.7	6	6.3	
Line Regulation (Note1)	ΔV_O	$I_O = 200\text{mA}$ $T_J = +25^\circ\text{C}$	-	-	100	mV
		$V_I = 8\text{V to } 25\text{V}$ $V_I = 9\text{V to } 25\text{V}$	-	-	50	
Load Regulation (Note1)	ΔV_O	$I_O = 5\text{mA to } 0.5\text{A}$, $T_J = +25^\circ\text{C}$	-	-	120	mV
		$I_O = 5\text{mA to } 200\text{mA}$, $T_J = +25^\circ\text{C}$	-	-	60	
Quiescent Current	I_Q	$T_J = +25^\circ\text{C}$	-	4.0	6.0	mA
Quiescent Current Change	ΔI_Q	$I_O = 5\text{mA to } 350\text{mA}$	-	-	0.5	mA
		$I_O = 200\text{mA}$ $V_I = 9\text{V to } 25\text{V}$	-	-	0.8	
Output Voltage Drift	$\Delta V/\Delta T$	$I_O = 5\text{mA}$ $T_J = 0 \text{ to } +125^\circ\text{C}$	-	-0.5	-	mV/ $^\circ\text{C}$
Output Noise Voltage	V_N	$f = 10\text{Hz to } 100\text{kHz}$	-	45	-	$\mu\text{V}/V_O$
Ripple Rejection	RR	$f = 120\text{Hz}$, $I_O = 300\text{mA}$ $V_I = 9\text{V to } 19\text{V}$, $T_J = +25^\circ\text{C}$	-	80	-	dB
Dropout Voltage	V_D	$T_J = +25^\circ\text{C}$, $I_O = 500\text{mA}$	-	2	-	V
Short Circuit Current	I_{SC}	$T_J = +25^\circ\text{C}$, $V_I = 35\text{V}$	-	300	-	mA
Peak Current	I_{PK}	$T_J = +25^\circ\text{C}$	-	700	-	mA

Note:

1. Load and line regulation are specified at constant junction temperature. Change in V_O due to heating effects must be taken into account separately. Pulse testing with low duty is used.

Electrical Characteristics (LR78M08) (Continued)

 (Refer to the test circuits, $0 \leq T_J \leq +125^\circ\text{C}$, $I_O=350\text{mA}$, $V_I=14\text{V}$, unless otherwise specified, $C_I = 0.33\mu\text{F}$, $C_O=0.1\mu\text{F}$)

Parameter	Symbol	Conditions	Min.	Typ.	Max.	Unit
Output Voltage	V_O	$T_J = +25^\circ\text{C}$	7.7	8	8.3	V
		$I_O = 5\text{mA to } 350\text{mA}$ $V_I = 10.5\text{V to } 23\text{V}$	7.6	8	8.4	
Line Regulation (Note1)	ΔV_O	$I_O = 200\text{mA}$ $T_J = +25^\circ\text{C}$	-	-	100	mV
		$V_I = 10.5\text{V to } 25\text{V}$ $V_I = 11\text{V to } 25\text{V}$	-	-	50	
Load Regulation (Note1)	ΔV_O	$I_O = 5\text{mA to } 0.5\text{A}$, $T_J = +25^\circ\text{C}$	-	-	160	mV
		$I_O = 5\text{mA to } 200\text{mA}$, $T_J = +25^\circ\text{C}$	-	-	80	
Quiescent Current	I_Q	$T_J = +25^\circ\text{C}$	-	4.0	6.0	mA
Quiescent Current Change	ΔI_Q	$I_O = 5\text{mA to } 350\text{mA}$	-	-	0.5	mA
		$I_O = 200\text{mA}$ $V_I = 10.5\text{V to } 25\text{V}$	-	-	0.8	
Output Voltage Drift	RR	$I_O = 5\text{mA}$ $T_J = 0 \text{ to } +125^\circ\text{C}$	-	-0.5	-	mV/ $^\circ\text{C}$
Output Noise Voltage	V_N	$f = 10\text{Hz to } 100\text{kHz}$	-	52	-	$\mu\text{V}/V_O$
Ripple Rejection	RR	$f = 120\text{Hz}$, $I_O = 300\text{mA}$ $V_I = 11.5\text{V to } 21.5\text{V}$, $T_J = +25^\circ\text{C}$	-	80	-	dB
Dropout Voltage	V_D	$T_J = +25^\circ\text{C}$, $I_O = 500\text{mA}$	-	2	-	V
Short Circuit Current	I_{SC}	$T_J = +25^\circ\text{C}$, $V_I = 35\text{V}$	-	300	-	mA
Peak Current	I_{PK}	$T_J = +25^\circ\text{C}$	-	700	-	mA

Note:

1. Load and line regulation are specified at constant junction temperature. Change in V_O due to heating effects must be taken into account separately. Pulse testing with low duty is used.

Electrical Characteristics (LR78M12) (Continued)

 (Refer to the test circuits, $0 \leq T_J \leq +125^\circ\text{C}$, $I_O=350\text{mA}$, $V_I=19\text{V}$, unless otherwise specified, $C_I=0.33\mu\text{F}$, $C_O=0.1\mu\text{F}$)

Parameter	Symbol	Conditions	Min.	Typ.	Max.	Unit
Output Voltage	V_O	$T_J = +25^\circ\text{C}$	11.5	12	12.5	V
		$I_O = 5\text{mA to } 350\text{mA}$ $V_I = 14.5\text{V to } 27\text{V}$	11.4	12	12.6	
Line Regulation (Note1)	ΔV_O	$I_O = 200\text{mA}$ $T_J = +25^\circ\text{C}$	-	-	100	mV
		$V_I = 14.5\text{V to } 30\text{V}$ $V_I = 16\text{V to } 30\text{V}$	-	-	50	
Load Regulation (Note1)	ΔV_O	$I_O = 5\text{mA to } 0.5\text{A}$, $T_J = +25^\circ\text{C}$	-	-	240	mV
		$I_O = 5\text{mA to } 200\text{mA}$, $T_J = +25^\circ\text{C}$	-	-	120	
Quiescent Current	I_Q	$T_J = +25^\circ\text{C}$	-	4.1	6.0	mA
Quiescent Current Change	ΔI_Q	$I_O = 5\text{mA to } 350\text{mA}$	-	-	0.5	mA
		$I_O = 200\text{mA}$ $V_I = 14.5\text{V to } 30\text{V}$	-	-	0.8	
Output Voltage Drift	$\Delta V/\Delta T$	$I_O = 5\text{mA}$ $T_J = 0 \text{ to } +125^\circ\text{C}$	-	-0.5	-	mV/ $^\circ\text{C}$
Output Noise Voltage	V_N	$f = 10\text{Hz to } 100\text{kHz}$	-	75	-	$\mu\text{V}/V_O$
Ripple Rejection	RR	$f = 120\text{Hz}$, $I_O = 300\text{mA}$ $V_I = 15\text{V to } 25\text{V}$, $T_J = +25^\circ\text{C}$	-	80	-	dB
Dropout Voltage	V_D	$T_J = +25^\circ\text{C}$, $I_O = 500\text{mA}$	-	2	-	V
Short Circuit Current	I_{SC}	$T_J = +25^\circ\text{C}$, $V_I = 35\text{V}$	-	300	-	mA
Peak Current	I_{PK}	$T_J = +25^\circ\text{C}$	-	700	-	mA

Note:

1. Load and line regulation are specified at constant junction temperature. Change in V_O due to heating effects must be taken into account separately. Pulse testing with low duty is used.

Electrical Characteristics (LR78M15) (Continued)

 (Refer to the test circuits, $0 \leq T_J \leq +125^\circ\text{C}$, $I_O=350\text{mA}$, $V_I=23\text{V}$, unless otherwise specified, $C_I=0.33\mu\text{F}$, $C_O=0.1\mu\text{F}$)

Parameter	Symbol	Conditions	Min.	Typ.	Max.	Unit
Output Voltage	V_O	$T_J = +25^\circ\text{C}$	14.4	15	15.6	V
		$I_O = 5\text{mA to } 350\text{mA}$ $V_I = 17.5\text{V to } 30\text{V}$	14.25	15	15.75	
Line Regulation (Note1)	ΔV_O	$I_O = 200\text{mA}$ $T_J = +25^\circ\text{C}$	-	-	100	mV
		$V_I = 17.5\text{V to } 30\text{V}$ $V_I = 20\text{V to } 30\text{V}$	-	-	50	
Load Regulation (Note1)	ΔV_O	$I_O = 5\text{mA to } 0.5\text{A}$, $T_J = +25^\circ\text{C}$	-	-	300	mV
		$I_O = 5\text{mA to } 200\text{mA}$, $T_J = +25^\circ\text{C}$	-	-	150	
Quiescent Current	I_Q	$T_J = +25^\circ\text{C}$	-	4.1	6.0	mA
Quiescent Current Change	ΔI_Q	$I_O = 5\text{mA to } 350\text{mA}$	-	-	0.5	mA
		$I_O = 200\text{mA}$ $V_I = 17.5\text{V to } 30\text{V}$	-	-	0.8	
Output Voltage Drift	$\Delta V/\Delta T$	$I_O = 5\text{mA}$ $T_J = 0 \text{ to } +125^\circ\text{C}$	-	-1	-	mV/ $^\circ\text{C}$
Output Noise Voltage	V_N	$f = 10\text{Hz to } 100\text{kHz}$	-	100	-	$\mu\text{V}/V_O$
Ripple Rejection	RR	$f = 120\text{Hz}$, $I_O = 300\text{mA}$ $V_I = 18.5\text{V to } 28.5\text{V}$, $T_J = +25^\circ\text{C}$	-	70	-	dB
Dropout Voltage	V_D	$T_J = +25^\circ\text{C}$, $I_O = 500\text{mA}$	-	2	-	V
Short Circuit Current	ISC	$T_J = +25^\circ\text{C}$, $V_I = 35\text{V}$	-	300	-	mA
Peak Current	IPK	$T_J = +25^\circ\text{C}$	-	700	-	mA

Note:

1. Load and line regulation are specified at constant junction temperature. Change in V_O due to heating effects must be taken into account separately. Pulse testing with low duty is used.

Electrical Characteristics (LR78M18) (Continued)

 (Refer to the test circuits, $0 \leq T_J \leq +125^\circ\text{C}$, $I_O=350\text{mA}$, $V_I=26\text{V}$, unless otherwise specified, $C_I=0.33\mu\text{F}$, $C_O=0.1\mu\text{F}$)

Parameter	Symbol	Conditions	Min.	Typ.	Max.	Unit
Output Voltage	V_O	$T_J = +25^\circ\text{C}$	17.3	18	18.7	V
		$I_O = 5\text{mA to } 350\text{mA}$ $V_I = 20.5\text{V to } 33\text{V}$	17.1	18	18.9	
Line Regulation (Note1)	ΔV_O	$I_O = 200\text{mA}$ $T_J = +25^\circ\text{C}$	-	-	100	mV
		$V_I = 21\text{V to } 33\text{V}$ $V_I = 24\text{V to } 33\text{V}$	-	-	50	
Load Regulation (Note1)	ΔV_O	$I_O = 5\text{mA to } 0.5\text{A}$, $T_J = +25^\circ\text{C}$	-	-	360	mV
		$I_O = 5\text{mA to } 200\text{mA}$, $T_J = +25^\circ\text{C}$	-	-	180	
Quiescent Current	I_Q	$T_J = +25^\circ\text{C}$	-	4.2	6.0	mA
Quiescent Current Change	ΔI_Q	$I_O = 5\text{mA to } 350\text{mA}$	-	-	0.5	mA
		$I_O = 200\text{mA}$ $V_I = 21\text{V to } 33\text{V}$	-	-	0.8	
Output Voltage Drift	$\Delta V/\Delta T$	$I_O = 5\text{mA}$, $T_J = 0 \text{ to } 125^\circ\text{C}$	-	-1.1	-	mV/ $^\circ\text{C}$
Output Noise Voltage	V_N	$f = 10\text{Hz to } 100\text{kHz}$	-	100	-	$\mu\text{V}/V_O$
Ripple Rejection	RR	$f = 120\text{Hz}$, $I_O = 300\text{mA}$, $V_I = 22\text{V to } 32\text{V}$ $T_J = +25^\circ\text{C}$	-	70	-	dB
Dropout Voltage	V_D	$T_J = +25^\circ\text{C}$, $I_O = 500\text{mA}$	-	2	-	V
Short Circuit Current	I_{SC}	$T_J = +25^\circ\text{C}$, $V_I = 35\text{V}$	-	300	-	mA
Peak Current	I_{PK}	$T_J = +25^\circ\text{C}$	-	700	-	mA

Note:

1. Load and line regulation are specified at constant junction temperature. Change in V_O due to heating effects must be taken into account separately. Pulse testing with low duty is used.

Electrical Characteristics (LR78M24) (Continued)

 (Refer to the test circuits, $0 \leq T_J \leq +125^\circ\text{C}$, $I_O=350\text{mA}$, $V_I=33\text{V}$, unless otherwise specified, $C_I=0.33\mu\text{F}$, $C_O=0.1\mu\text{F}$)

Parameter	Symbol	Conditions	Min.	Typ.	Max.	Unit
Output Voltage	V_O	$T_J = +25^\circ\text{C}$	23	24	25	V
		$I_O = 5\text{mA to } 350\text{mA}$ $V_I = 27\text{V to } 38\text{V}$	22.8	24	25.2	
Line Regulation (Note1)	ΔV_O	$I_O = 200\text{mA}$ $T_J = +25^\circ\text{C}$	-	-	100	mV
		$V_I = 27\text{V to } 38\text{V}$ $V_I = 28\text{V to } 38\text{V}$	-	-	50	
Load Regulation (Note1)	ΔV_O	$I_O = 5\text{mA to } 0.5\text{A}$, $T_J = +25^\circ\text{C}$	-	-	480	mV
		$I_O = 5\text{mA to } 200\text{mA}$, $T_J = +25^\circ\text{C}$	-	-	240	
Quiescent Current	I_Q	$T_J = +25^\circ\text{C}$	-	4.2	6.0	mA
Quiescent Current Change	ΔI_Q	$I_O = 5\text{mA to } 350\text{mA}$	-	-	0.5	mA
		$I_O = 200\text{mA}$ $V_I = 27\text{V to } 38\text{V}$	-	-	0.8	
Output Voltage Drift	$\Delta V/\Delta T$	$I_O = 5\text{mA}$ $T_J = 0 \text{ to } +125^\circ\text{C}$	-	-1.2	-	mV/ $^\circ\text{C}$
Output Noise Voltage	V_N	$f = 10\text{Hz to } 100\text{kHz}$	-	170	-	$\mu\text{V}/V_O$
Ripple Rejection	RR	$f = 120\text{Hz}$, $I_O = 300\text{mA}$ $V_I = 28\text{V to } 38\text{V}$, $T_J = +25^\circ\text{C}$	-	70	-	dB
Dropout Voltage	V_D	$T_J = +25^\circ\text{C}$, $I_O = 500\text{mA}$	-	2	-	V
Short Circuit Current	I_{SC}	$T_J = +25^\circ\text{C}$, $V_I = 35\text{V}$	-	300	-	mA
Peak Current	I_{PK}	$T_J = +25^\circ\text{C}$	-	700	-	mA

Note:

1. Load and line regulation are specified at constant junction temperature. Change in V_O due to heating effects must be taken into account separately. Pulse testing with low duty is used.

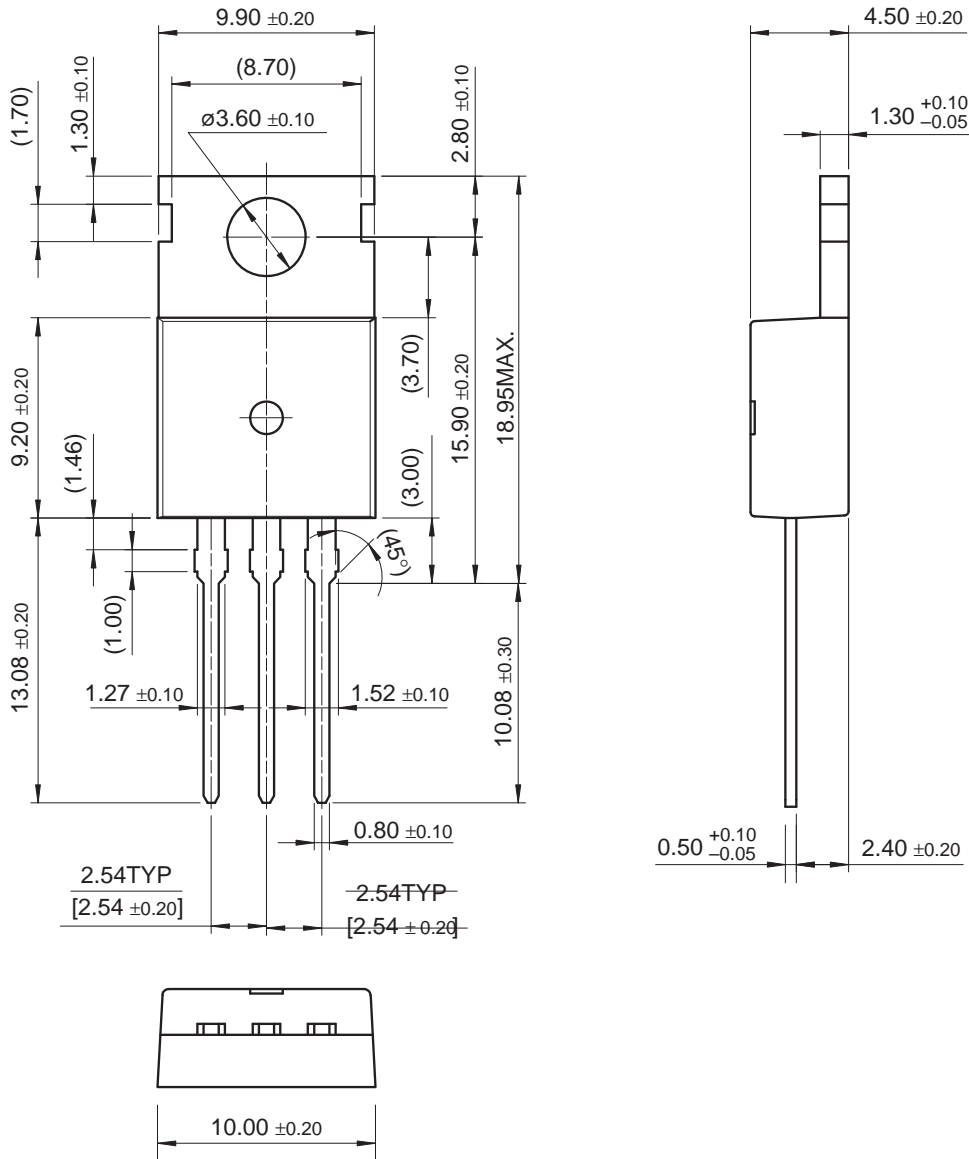
Mechanical Dimensions
Package
Dimensions in millimeters
TO-220

Mechanical Dimensions (Continued)

Package

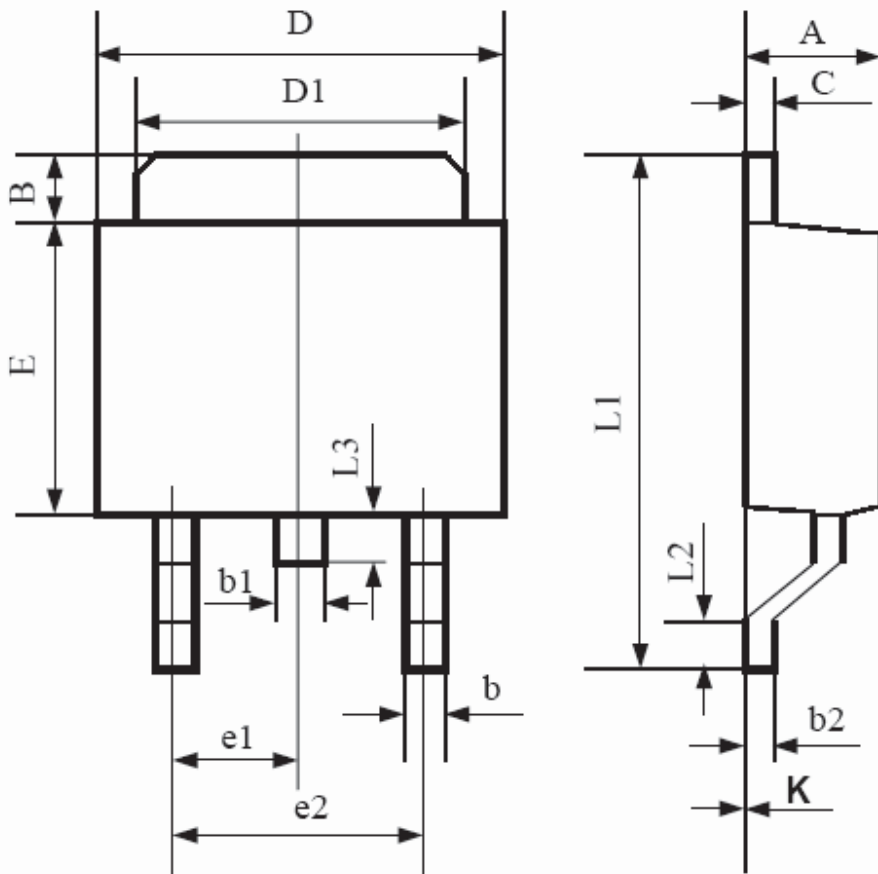
D-PAK

symbol	Dimensions In Millimeters		Dimensions In Inches	
	Min	Max	Min	Max
A	2.20	2.40	0.087	0.094
B	1.20	1.50	0.047	0.059
b	0.50	0.70	0.020	0.027
b1	0.70	0.90	0.028	0.035
b2	0.46	0.56	0.018	0.022
C	0.46	0.56	0.018	0.022
D	6.35	6.65	0.250	0.262
D1	5.20	5.40	0.205	0.212
E	5.40	5.60	0.212	0.220
e1	2.25	2.35	0.089	0.093
e2	4.50	4.70	0.177	0.185
L1	9.25	9.75	0.346	0.384
L2	0.95	1.45	0.037	0.057
L3	0.90	1.10	0.035	0.043
K	-0.1	0.00	-0.004	0.000

Product Marking

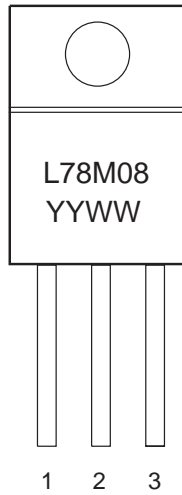

TO-220

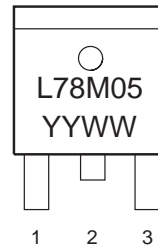

D-PAK
(TO-252)

Ordering Information

Product Number	Type	Ship Min Package
LR78M05	TO-220	50 Units/ Tube
LR78M06		
LR78M08		
LR78M12		
LR78M15		
LR78M18		
LR78M24		
LR78M05D	D-PAK	2500 Units/ Reel
LR78M06D		
LR78M08D		
LR78M12D		

X-ON Electronics

Largest Supplier of Electrical and Electronic Components

Click to view similar products for [Linear Voltage Regulators](#) category:

Click to view products by [Leshan](#) manufacturer:

Other Similar products are found below :

[LV5684PVD-XH](#) [MCDTSA6-2R](#) [L7815ACV-DG](#) [LV56801P-E](#) [UA7805CKC](#) [714954EB](#) [ZMR500QFTA](#) [BA033LBSG2-TR](#)

[NCV78M05ABDTRKG](#) [LV5680P-E](#) [L79M05T-E](#) [L78LR05D-MA-E](#) [NCV317MBTG](#) [NTE7227](#) [MP2018GZD-33-P](#) [MP2018GZD-5-P](#)

[LV5680NPVC-XH](#) [ZTS6538SE](#) [UA78L09CLP](#) [UA78L09CLPR](#) [CAT6221-PPTD-GT3](#) [MC78M09CDTRK](#) [NCV51190MNTAG](#)

[BL1118CS8TR1833](#) [BL8563CKETR18](#) [BL8077CKETR33](#) [BL9153-33CC3TR](#) [BL9161G-15BADRN](#) [BL9161G-28BADRN](#)

[BRCO7530MMC](#) [CJ7815B-TFN-ARG](#) [LM317C](#) [GM7333K](#) [GM7350K](#) [XC6206P332MR](#) [HT7533](#) [LM7912S/TR](#) [LT1764S/TR](#) [LM7805T](#)

[LM338T](#) [LM1117IMP-3.3/TR](#) [HT1117AM-3.3](#) [HT7550S](#) [AMS1117-3.3](#) [HT7150S](#) [78L12](#) [HT7550](#) [HT7533-1](#) [HXY6206I-2.5](#) [HT7133](#)