

LSI1012XT1G

S-LSI1012XT1G

N-Channel 1.8-V (G-S) MOSFET

1. FEATURES

- Gate-Source ESD Protected
- High-Side Switching
- Low On-Resistance: 0.7Ω
- Low Threshold: 0.8 V (typ)
- Fast Switching Speed: 10 ns
- We declare that the material of product compliance with RoHS requirements and Halogen Free.
- S- prefix for automotive and other applications requiring unique site and control change requirements; AEC-Q101 qualified and PPAP capable.

2. APPLICATION

- Drivers: Relays, Solenoids, Lamps, Hammers, Displays, Memories
- Battery Operated Systems
- Power Supply Converter Circuits
- Load/Power Switching Cell Phones, Pagers

3. DEVICE MARKING AND RESISTOR VALUES

Device	Marking	Shipping
LSI1012XT1G	A	3000/Tape&Reel
LSI1012XT3G	A	10000/Tape&Reel

4. MAXIMUM RATINGS(Ta = 25°C)

Parameter	Symbol	5 secs	Steady State	Unit
Drain-Source Voltage	VDS	20		V
Gate-Source Voltage	VGS	±6		V
Continuous Drain Current (TJ = 150°C) (Note 2)	ID	TA = 25°C	500	mA
		TA = 85°C	350	
Pulsed Drain Current(Note 1)	IDM	1000		
Continuous Source Current (diode conduction)(Note 2)	IS	275	250	
Maximum Power Dissipation(Note 2)	PD	TA = 25°C	250	mW
		TA = 85°C	140	
Operating Junction and Storage Temperature Range	TJ , Tstg	-55 ~+150		°C

1.Pulse test; pulse width ≤300 μs, duty cycle ≤2%.

2.Guaranteed by design, not subject to production testing.

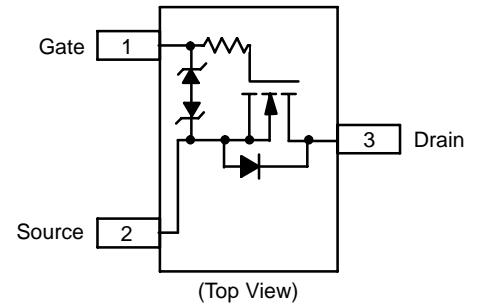
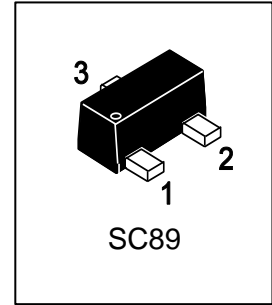

MARKING DIAGRAM

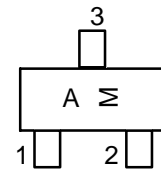

A = Specific Device Code
M = Month Code

5. ELECTRICAL CHARACTERISTICS (Ta= 25°C)

Static

Characteristic	Symbol	Min.	Typ.	Max.	Unit
Drain-Source Breakdown Voltage (VGS = 0V, ID = 250μA)	V(BR)DSS	20	-	-	V
Gate Threshold Voltage (VDS = VGS, ID = 250μA)	VGS(th)	0.45	-	0.9	V
Gate-Body Leakage (VDS = 0 V, VGS = ±4.5 V)	IGSS	-	±0.5	±1	μA
Zero Gate Voltage Drain Current (VDS = 20 V, VGS = 0 V) (VDS = 20 V, VGS = 0 V, TJ = 85°C)	IDSS	-	0.3	100	nA μA
Drain-Source On-State Resistance(Note 1) (VGS = 4.5 V, ID = 600 mA) (VGS = 2.5 V, ID = 500 mA) (VGS = 1.8 V, ID = 350 mA)	RDS(on)	-	0.41 0.53 0.7	0.7 0.85 1.25	Ω
Diode Forward Voltage(Note 1) (IS = 150 mA, VGS = 0 V)	VSD	-	0.8	1.2	V

Dynamic(Note 2)

Total Gate Charge	(VDS = 10 V, VGS = 4.5 V, ID = 250 mA)	Qg	-	750	-	pC
Gate-Source Charge		Qgs	-	75	-	
Gate-Drain Charge		Qgd	-	225	-	
Turn-On Delay Time	(VDD = 10 V, RL = 47Ω, ID=200 mA, VGEN = 4.5 V, RG = 10Ω)	td(on)	-	5	-	ns
Rise Time		tr	-	5	-	
Turn-Off Delay Time		td(off)	-	25	-	
Fall Time		tf	-	11	-	

6.ELECTRICAL CHARACTERISTICS CURVES

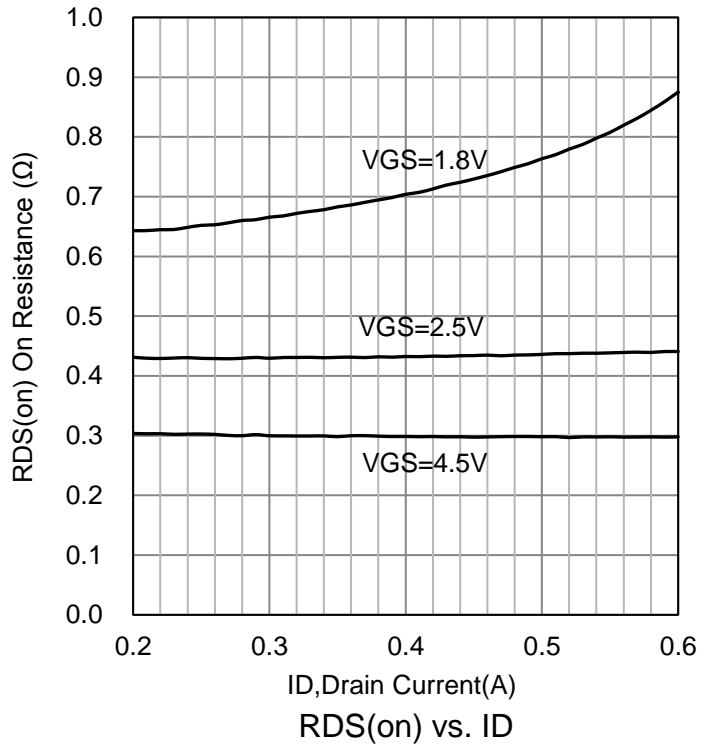
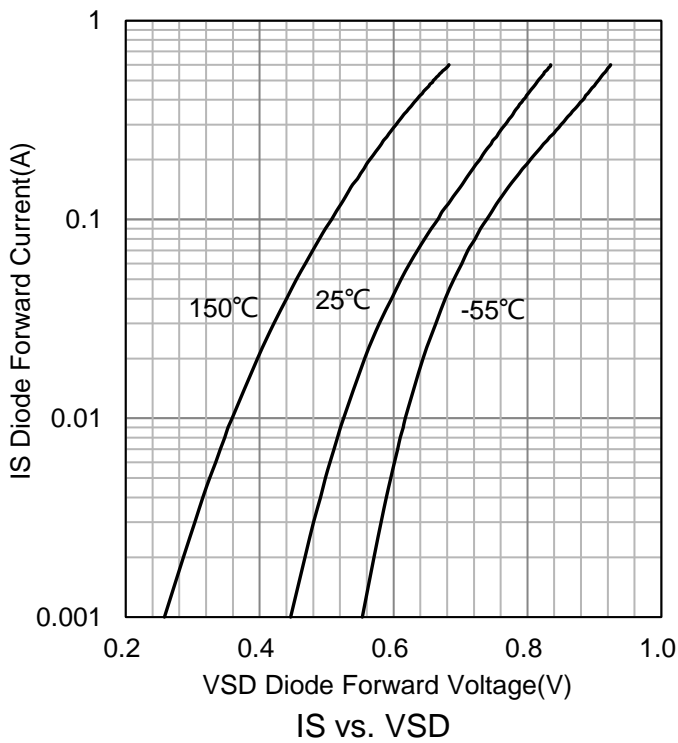
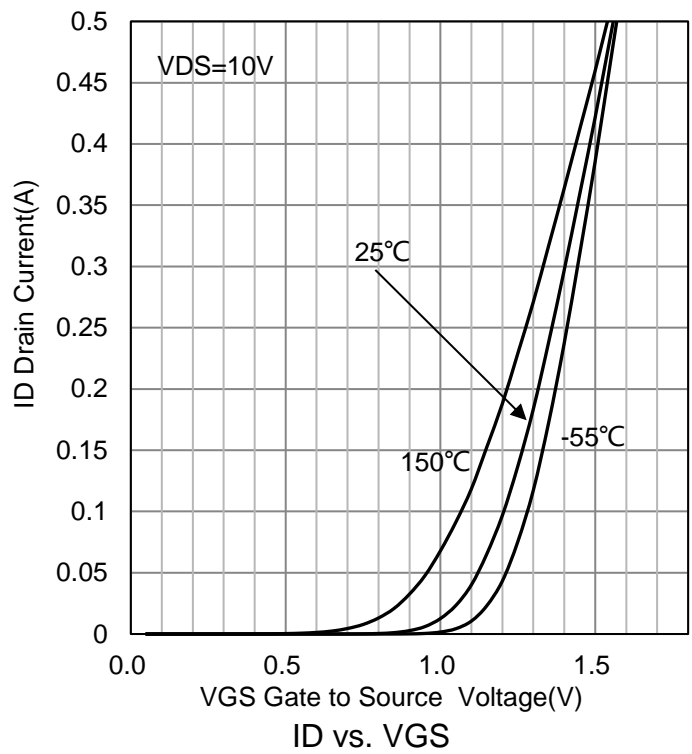
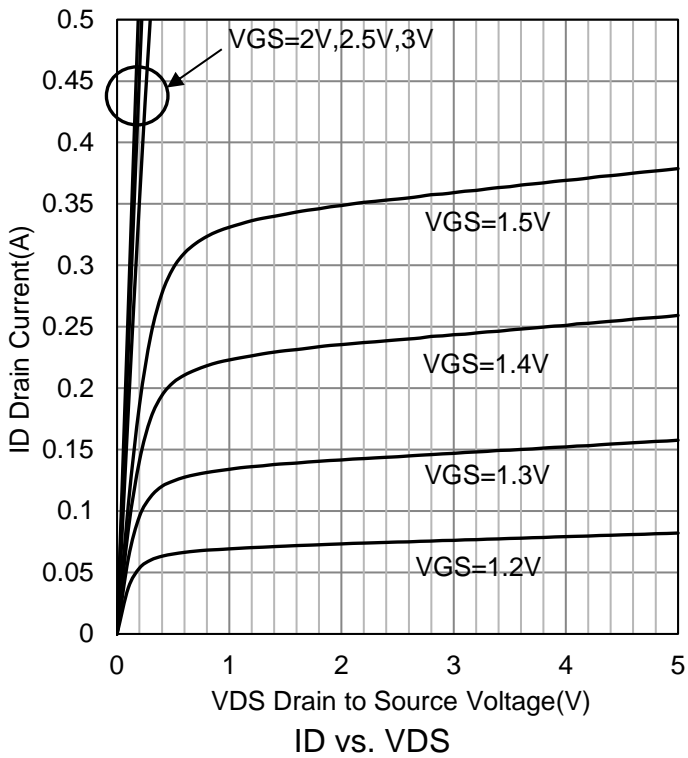

6.ELECTRICAL CHARACTERISTICS CURVES(Con.)

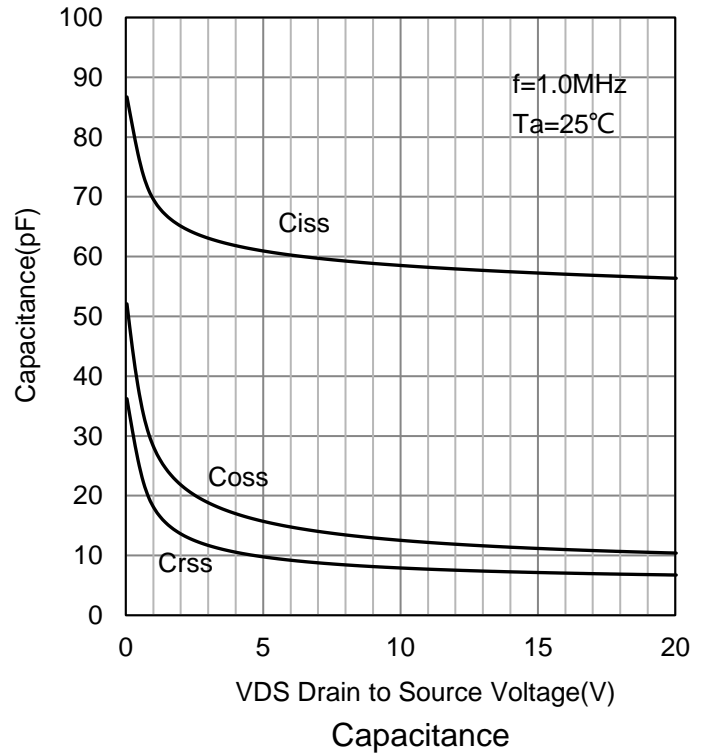
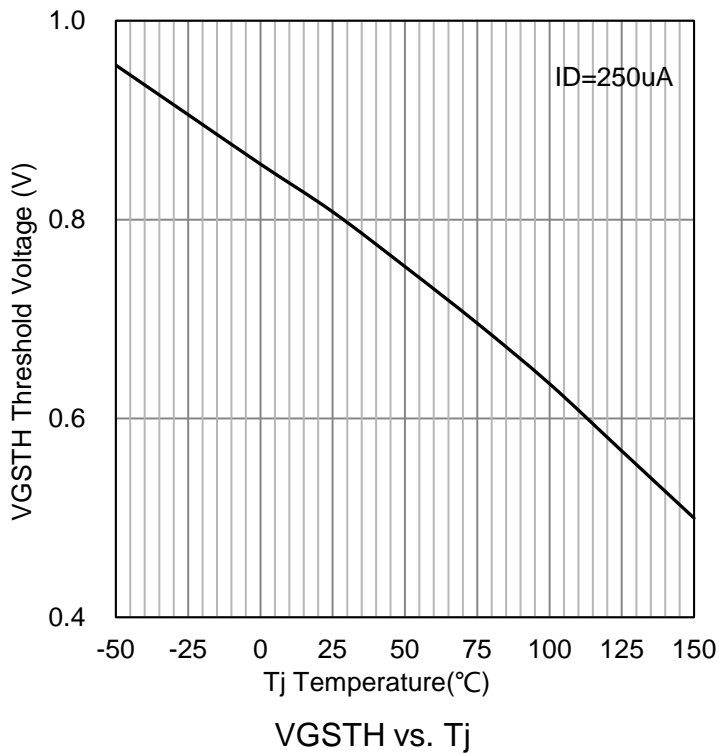
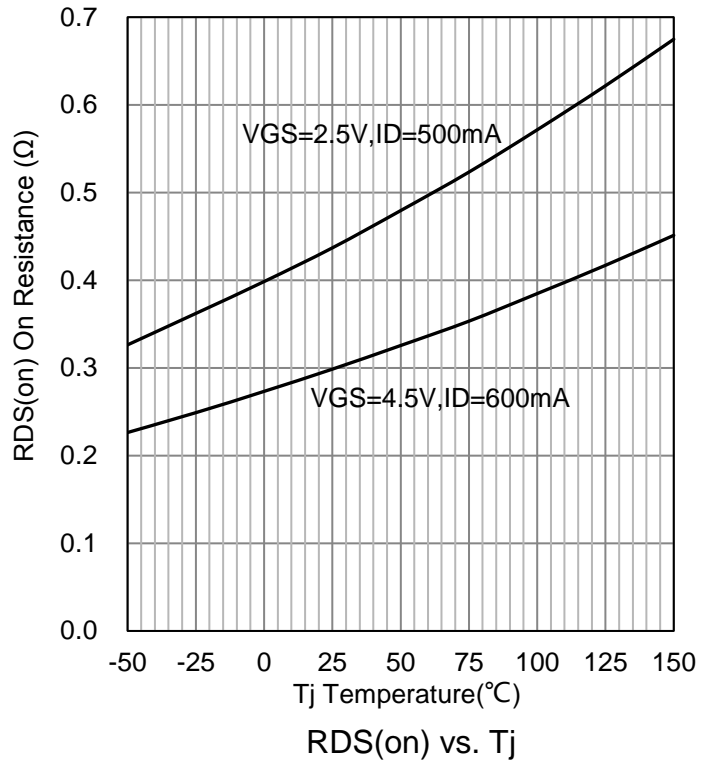
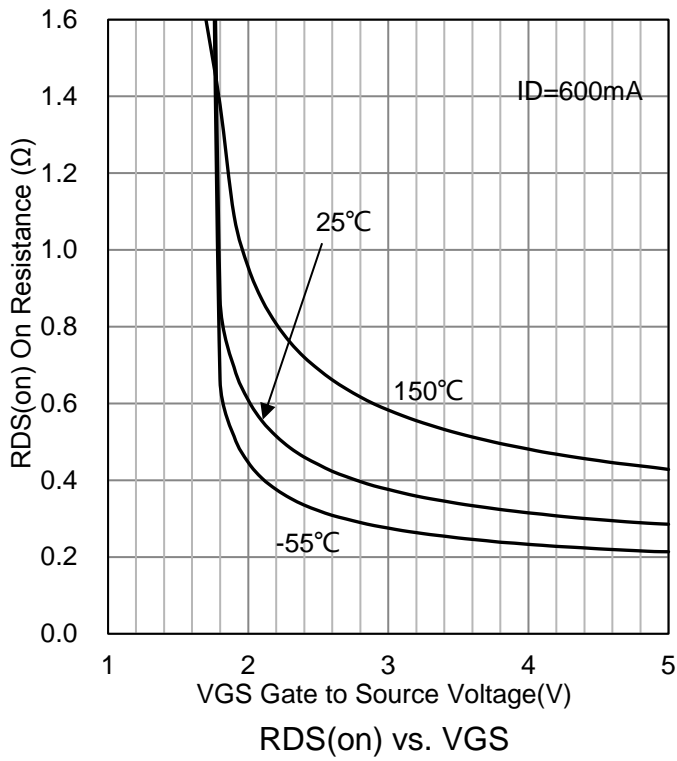

7. OUTLINE AND DIMENSIONS

Notes:

1. DIMENSIONING AND TOLERANCING PER ANSI Y14.5M, 1982.
2. CONTROLLING DIMENSION: MILLIMETERS.
3. MAXIMUM LEAD THICKNESS INCLUDES LEAD FINISH. MINIMUM LEAD THICKNESS IS THE MINIMUM THICKNESS OF BASE MATERIAL.
4. DIMENSIONS A AND B DO NOT INCLUDE MOLD FLASH, PROTRUSIONS OR GATE BURRS.

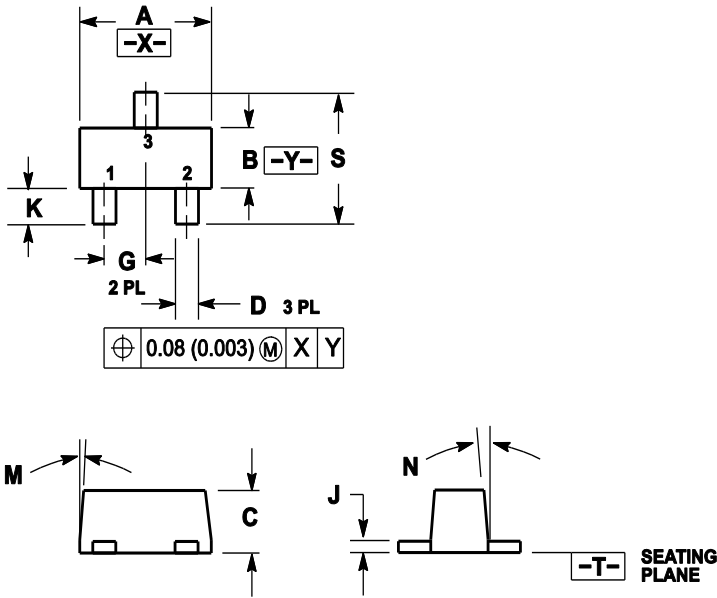

DIM	MILLIMETERS			INCHES		
	MIN	NOM	MAX	MIN	NOM	MAX
A	1.50	1.60	1.70	0.059	0.063	0.067
B	0.75	0.85	0.95	0.030	0.034	0.040
C	0.60	0.70	0.80	0.024	0.028	0.031
D	0.23	0.28	0.33	0.009	0.011	0.013
G	0.50BSC			0.020BSC		
H	0.53REF			0.021REF		
J	0.10	0.15	0.20	0.004	0.006	0.008
K	0.30	0.40	0.50	0.012	0.016	0.02
L	1.10REF			0.043REF		
M	---	---	10°	---	---	10°
N	---	---	10°	---	---	10°
S	1.50	1.60	1.70	0.059	0.063	0.067

8. SOLDERING FOOTPRINT

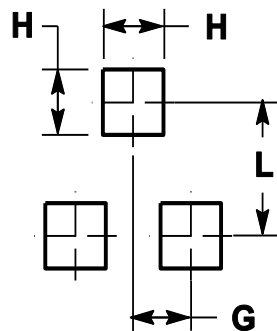

DISCLAIMER

- Before you use our Products, you are requested to carefully read this document and fully understand its contents. LRC shall not be in any way responsible or liable for failure, malfunction or accident arising from the use of any LRC's Products against warning, caution or note contained in this document.
- All information contained in this document is current as of the issuing date and subject to change without any prior notice. Before purchasing or using LRC's Products, please confirm the latest information with a LRC sales representative.

X-ON Electronics

Largest Supplier of Electrical and Electronic Components

Click to view similar products for [MOSFET](#) category:

Click to view products by [Leshan](#) manufacturer:

Other Similar products are found below :

[IRFD120](#) [IRFF430](#) [JANTX2N5237](#) [2SK2267\(Q\)](#) [BUK455-60A/B](#) [TK100A10N1,S4X\(S](#) [MIC4420CM-TR](#) [VN1206L](#) [NDP4060](#) [SI4482DY](#)
[IRS2092STRPBF-EL](#) [IPS70R2K0CEAKMA1](#) [SQM120N06-3M5L-GE3](#) [TK31J60W5,S1VQ\(O](#) [TK31J60W,S1VQ\(O](#) [TK16J60W,S1VQ\(O](#)
[2SK2614\(TE16L1,Q\)](#) [DMN1017UCP3-7](#) [EFC2J004NUZTDG](#) [P85W28HP2F-7071](#) [NTE2384](#) [DMC2700UDMQ-7](#) [DMN2080UCB4-7](#)
[DMN61D9UWQ-13](#) [US6M2GTR](#) [DMN31D5UDJ-7](#) [DMP22D4UFO-7B](#) [IPS60R3K4CEAKMA1](#) [DMN1006UCA6-7](#) [DMN16M9UCA6-7](#)
[STF5N65M6](#) [IRF40H233XTMA1](#) [STU5N65M6](#) [DMN6022SSD-13](#) [DMN13M9UCA6-7](#) [DMTH10H4M6SPS-13](#) [IPS60R360PFD7SAKMA1](#)
[DMN2990UFB-7B](#) [SSM3K35CT,L3F](#) [IPLK60R1K0PFD7ATMA1](#) [2N7002W-G](#) [MCAC30N06Y-TP](#) [IPWS65R035CFD7AXKSA1](#)
[MCQ7328-TP](#) [SSM3J143TU,LXHF](#) [DMN12M3UCA6-7](#) [PJMF280N65E1_T0_00201](#) [PJMF380N65E1_T0_00201](#)
[PJMF280N60E1_T0_00201](#) [PJMF600N65E1_T0_00201](#)