

Programmable Precision Reference

LTL431XXTSLT1G

DESCRIPTION

The LTL431 is a three-terminal adjustable regulator with a guaranteed thermal stability over applicable temperature ranges. The output voltage may be set to any value between V_{ref} (approximately 2.5V) and 36V with two external resistors. It provides very wide applications, including shunt regulator, series regulator, switching regulator, voltage reference and others.

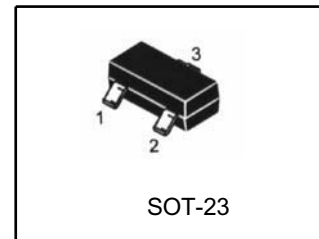

1: Cathode; 2: Ref; 3: Anode

FEATURES

- Programmable output Voltage to 36V.
- Low dynamic output impedance 0.2Ω
- Sink current capability of 1 to 100mA.
- Equivalent full-range temperature coefficient of $50\text{ppm}/^\circ\text{C}$ typical for operation over full rated operating temperature range.
- ESD Enhanced; HBM 4000V

Pb-Free package is available

BLOCK DIAGRAM

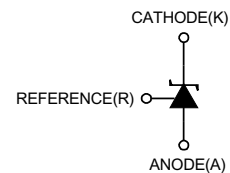
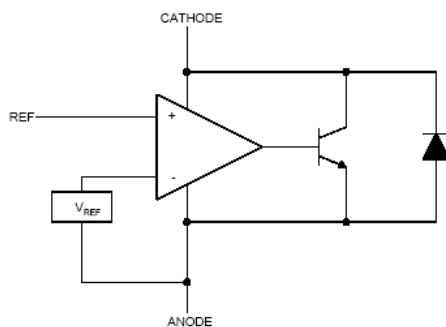

ABSOLUTE MAXIMUM RATINGS (Operating temperature range applies unless otherwise specified)

PARAMETER	SYMBOL	VALUE	UNIT
Cathode Voltage	V _{KA}	36	V
Cathode Current Range(Continuous)	I _{KA}	-100 ~ +150	mA
Reference Input Current Range	I _{ref}	-0.05 ~ +10	mA
Operating Junction Temperature	T _j	150	°C
Operating Ambient Temperature	T _{opr}	-40 ~ +125	°C
Storage Temperature Temperature	T _{stg}	-65 ~ +150	°C

RECOMMENDED OPERATING CONDITIONS

PARAMETER	SYMBOL	MIN	TYP	MAX	UNIT
Cathode Voltage	V _{KA}	V _{REF}		36	V
Cathode Current	I _{KA}	0.5		100	mA

ELECTRICAL CHARACTERISTICS (T_a=25°C, unless otherwise specified)

Characteristic		Symbol	Test conditions	MIN	TYP	MAX	UNIT	
Reference Input Voltage 1	0.5%	V _{ref}	V _{KA} =V _{REF} , I _{KA} =10mA	2.488	2.50	2.512	V	
	1%			2.475	2.50	2.525		
	2%			2.450	2.50	2.550		
Reference Input Voltage 2*	0.5%	V _{ref}	V _{KA} =V _{REF} , I _{KA} =10mA	2.483	2.495	2.507	V	
	1%			2.470	2.495	2.520		
	2%			2.445	2.495	2.545		
Deviation of reference Input Voltage Over temperature		ΔV _{ref}	V _{KA} =V _{REF} , I _{KA} =10mA T _{MIN} ≤ T _A ≤ T _{MAX}		4.5	25	mV	
Ratio of Change in Reference Input Voltage to the Change in Cathode Voltage		ΔV _{ref} /ΔV _{KA}	I _{KA} =10mA	ΔV _{KA} =10V~V _{REF}		-1.0	-2.7	mV/V
				ΔV _{KA} =36V~10V		-0.5	-2.0	
Reference Input Current		I _{ref}	I _{KA} =10mA, R ₁ =10kΩ, R ₂ =∞		1	2	μA	
Deviation of Reference Input Current Over Full Temperature Range		ΔI _{ref} /ΔT	I _{KA} =10mA, R ₁ =10kΩ, R ₂ =∞, T _A =full Temperature		0.2	0.4	μA	
Minimum cathode current for regulation		I _{KA} (min)	V _{KA} =V _{REF}		0.3	0.5	mA	
Off-state cathode Current		I _{KA} (OFF)	V _{KA} =36V, V _{REF} =0		0.05	0.5	μA	
Dynamic Impedance		Z _{KA}	V _{KA} =V _{REF} , I _{KA} =1 to 100mA f ≤ 1.0kHz		0.15	0.5	Ω	

*** CLASSIFICATION OF V_{ref} AND PACKAGE**

Type	Rank	Range(V)	Marking	Package	T _{opr}
LTL431ATSLT1G	0.5%	2.488~2.512	LAS	SOT-23	-40~+125 °C
LTL431BTSLS1G	1%	2.475~2.525	LBS	SOT-23	-40~+125 °C
LTL431APTSLT1G	0.5%	2.483~2.507	LCS	SOT-23	-40~+125 °C
LTL431BPTSLT1G	1%	2.470~2.520	LDS	SOT-23	-40~+125 °C

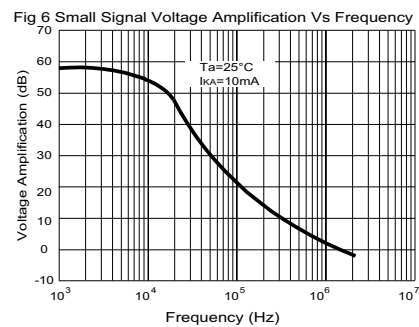
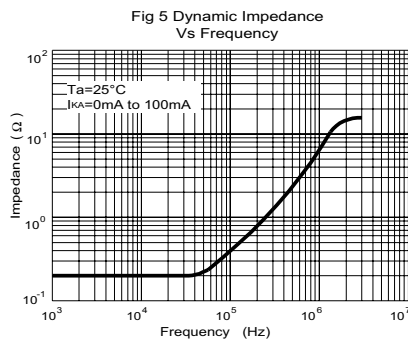
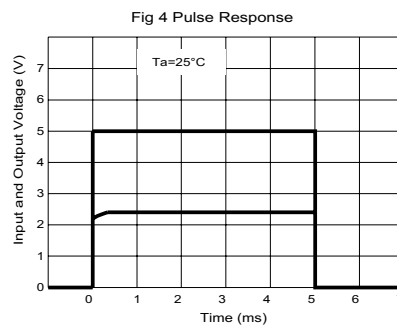
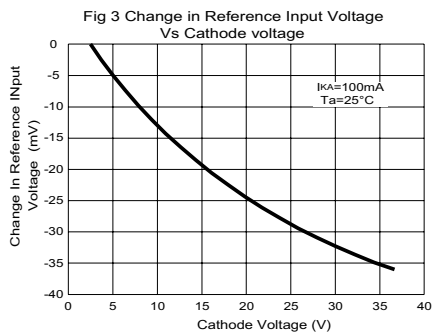
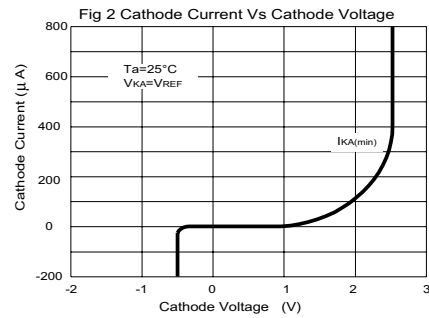
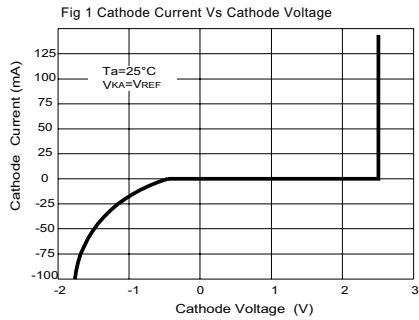
TYPICAL PERFORMANCE CHARACTERISTICS

TEST CIRCUIT

 Fig 7 Test Circuit For $V_{KA}=V_{REF}$

 Fig 8 Test Circuit for $V_{KA} \geq V_{REF}$

 Fig 9 Test Circuit For $I_{KA(OFF)}$
APPLICATION CIRCUIT

Fig 10 Shutdown Regulator

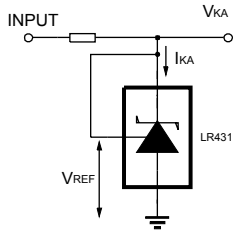
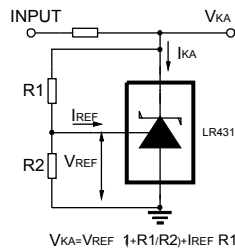
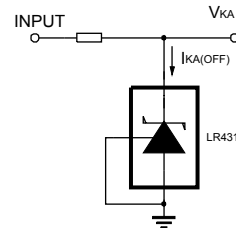
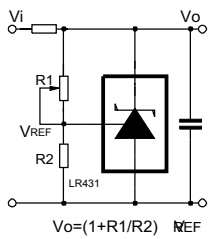
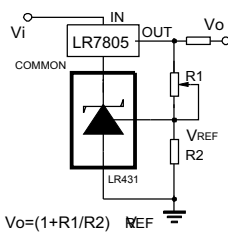

Fig 11 Output Control of a Three-Terminal Fixed Regulator

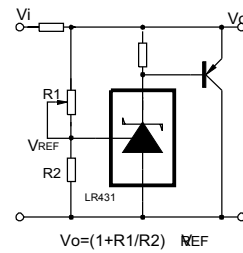

Fig 12 Higher-current Shunt Regulator

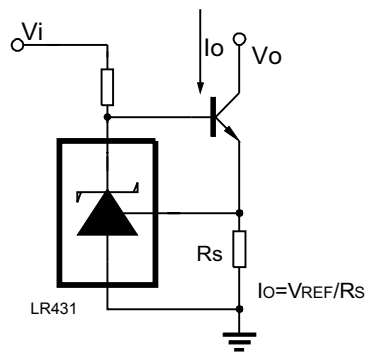

Fig 13 Constant-current Sink

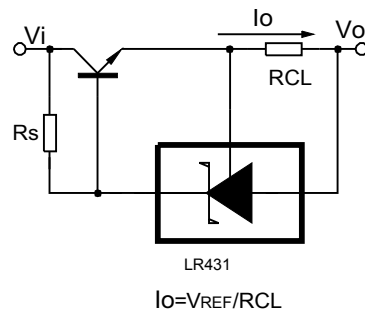
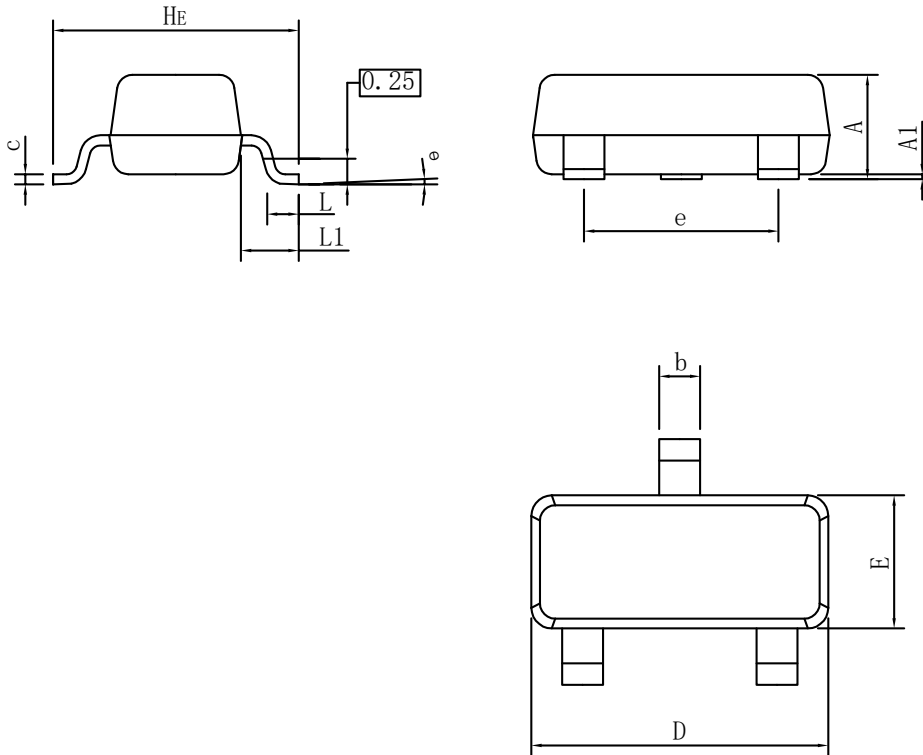

Fig 14 Current Limiting or Current Source

SOT-23 PACKAGE OUTLINE DIMENSIONS

SOT23			
DIM	MIN	NOR	MAX
A	0.90	1.00	1.10
A1	0.01	0.06	0.10
b	0.30	0.40	0.50
c	0.10	0.17	0.20
D	2.80	2.90	3.00
E	1.20	1.30	1.40
e	1.80	1.90	2.00
L	0.20	0.40	0.60
L1	0.60REF		
HE	2.20	2.40	2.60
θ	0°	-	10°
All Dimensions in mm			

GENERAL NOTES

1. Top package surface finish $Ra0.4 \pm 0.2\mu m$
2. Bottom package surface finish $Ra0.7 \pm 0.2\mu m$
3. Side package surface finish $Ra0.4 \pm 0.2\mu m$

X-ON Electronics

Largest Supplier of Electrical and Electronic Components

Click to view similar products for [Voltage References](#) category:

Click to view products by [Leshan](#) manufacturer:

Other Similar products are found below :

[5962-8686103XC](#) [LT1460GIZ-5PBF](#) [LT1009IZPBF](#) [NCV431BVDMR2G](#) [REF01J/883](#) [SC431ILPRAG](#) [AP432AQG-7](#) [LM4040B25QFTA](#)
[TL431BL3T](#) [BR431M](#) [MC1403BM/TR](#) [HT431BRZ](#) [ME4315AM6G-2](#) [ME4315AM6G-1](#) [TL431A-YK](#) [TL431](#) [TL431-1](#) [TL431](#) [TL431](#)
[XC6206P332MR](#) [HT431CRZ](#) [LM285M-1.2/TR](#) [S-LR431AKLT1G](#) [LR431AKLT1G](#) [LTL432ATLT1G](#) [TL431](#) [TP431CS3-1](#)
[LTL431APTSLT1G](#) [TP431CS3](#) [TL432](#) [TPR3530-S3TR](#) [LM236M-5.0/TR](#) [HT431ARZ](#) [TL431ACZ](#) [KA431SLMF2TF](#) [KA431SMF2TF](#)
[KA431SMFTF](#) [LM4040QCEM3-3.0/NOPB](#) [LM4041C12ILPR](#) [LM4050AIM3X-5.0/NOPB](#) [LM4120AIM5-2.5/NOP](#) [LM431SCCMFX](#)
[ZXRE250BSA-7](#) [ZXRE125DN8TA](#) [TS3330AQPR](#) [ZXRE250ASA-7](#) [ZTL431ASE5TA](#) [REF3012AIDBZR](#) [LM385BM-2.5/NOPB](#) [LM385D-](#)
[2.5R2G](#)