

Programmable Precision Reference

S-LR431XXKLT1G

DESCRIPTION

The S-LR431 is a three-terminal adjustable regulator with a guaranteed thermal stability over applicable temperature ranges. The output voltage may be set to any value between V_{ref} (approximately 2.5V) and 36V with two external resistors. It provides very wide applications, including shunt regulator, series regulator, switching regulator, voltage reference and others.

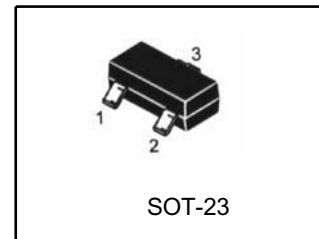

SOT-23 1: Ref; 2: Cathode; 3: Anode

FEATURES

- Low Dynamic output impedance 0.1 Ω (Typ)
- Adjustable output voltage
- Fast turn-on response
- Sink current capability of 0.1mA to 100mA
- Low output noise
- Industrial temperature range
- Excellent temperature coefficient 25ppm/ $^{\circ}$ C
- Electrostatic discharge voltage 2.5kV
- S- Prefix for Automotive and Other Applications Requiring Unique Site and Control Change Requirements; AEC-Q100 Qualified and PPAP Capable.

BLOCK DIAGRAM

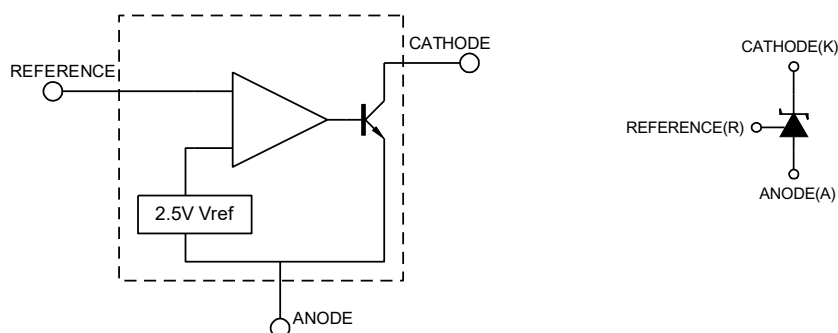

ABSOLUTE MAXIMUM RATINGS (Operating temperature range applies unless otherwise specified)

PARAMETER	SYMBOL	VALUE	UNIT
Cathode Voltage	V _{KA}	40	V
Cathode Current Range(Continuous)	I _{KA}	-100 ~ +150	mA
Reference Input Current Range	I _{ref}	-0.05 ~ +10	mA
Operating Junction Temperature	T _j	150	°C
Thermal Resistance	θ _{JA}	206	°C/W
Operating Ambient Temperature	T _{opr}	-40 ~ +125	°C
Storage Temperature	T _{stg}	-65 ~ +150	°C

RECOMMENDED OPERATING CONDITIONS

PARAMETER	SYMBOL	MIN	TYP	MAX	UNIT
Cathode Voltage	V _{KA}	V _{REF}		36	V
Cathode Current	I _{KA}	0.3		100	mA

ELECTRICAL CHARACTERISTICS(T_a=25°C,unless otherwise specified)

Characteristic		Symbol	Test Conditions	Min	Typ	Max	Unit
Reference Input Voltage 1	0.5%	V _{ref}	V _{KA} =V _{REF} ,I _{KA} =10mA	2.488	2.50	2.512	V
	1%			2.475	2.50	2.525	
	2%			2.450	2.50	2.550	
Reference Input Voltage 2	0.5%	V _{ref}	V _{KA} =V _{REF} ,I _{KA} =10mA	2.483	2.495	2.507	V
	1%			2.470	2.495	2.520	
	2%			2.445	2.495	2.545	
Deviation of reference Input Voltage Over temperature		ΔV _{ref}	V _{KA} =V _{REF} ,I _{KA} =10mA T _{MIN} ≤T _A ≤T _{MAX}		15	35	mV
			V _{KA} =V _{REF} ,I _{KA} =10mA T _A =0 to 125°C		8	17	mV
Ratio of Change in Reference Input Voltage to the Change in Cathode Voltage		ΔV _{ref} /ΔV _{KA}	I _{KA} =10mA	ΔV _{KA} =10V~V _{REF}	-2.7	-1.0	mV/V
				ΔV _{KA} =36V~10V	-2	-0.4	
Reference Input Current		I _{ref}	I _{KA} =10mA,R1=10kΩ,R2=∞		0.5	1.2	μA
Deviation of Reference Input Current Over Full Temperature Range		ΔI _{ref} /ΔT	I _{KA} =10mA,R1=10kΩ,R2=∞ T _A =full Temperature		0.4	1.2	μA
Minimum cathode current for regulation		I _{KA} (min)	V _{KA} =V _{REF}		0.08	0.3	mA
Off-state cathode Current		I _{KA} (OFF)	V _{KA} =36V,V _{REF} =0		0.01	0.8	μA
Dynamic Impedance		Z _{KA}	V _{KA} =V _{REF} ,I _{KA} =0.2 to 100mA f _≤ 1.0kHz		0.1	0.37	Ω

CLASSIFICATION OF V_{ref} AND PACKAGE

Type	RanK	Range(V)	Marking	Package	T _{opr}
S-LR431AKLT1G	0.5%	2.488~2.512	AK	SOT-23	-40~+125 °C
S-LR431BKLT1G	1%	2.475~2.525	BK	SOT-23	-40~+125 °C
S-LR431APKLT1G	0.5%	2.483~2.507	CK	SOT-23	-40~+125 °C
S-LR431BPKLT1G	1%	2.470~2.520	DK	SOT-23	-40~+125 °C

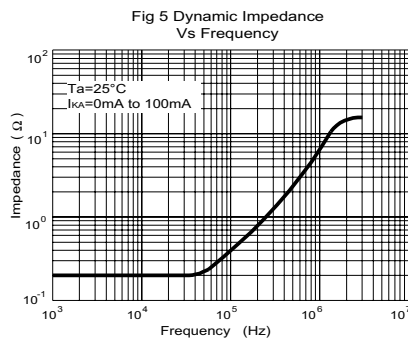
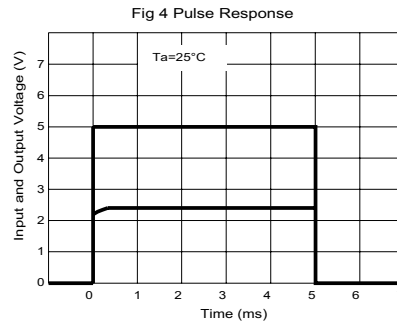
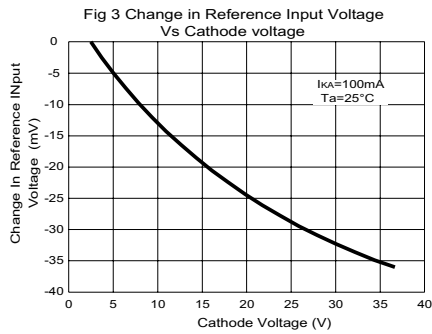
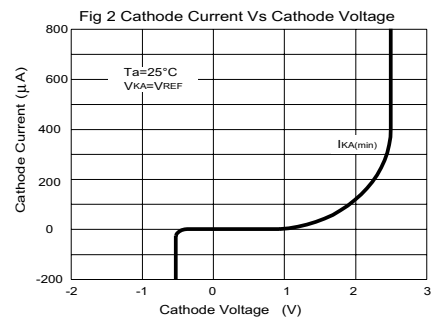
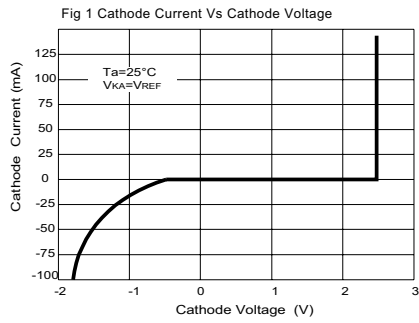
TYPICAL PERFORMANCE CHARACTERISTICS

TEST CIRCUIT

 Fig 6 Test Circuit For $V_{KA}=V_{REF}$

 Fig 7 Test Circuit for $V_{KA} \geq V_{REF}$

 Fig 8 Test Circuit For $I_{KA(OFF)}$
APPLICATION CIRCUIT

Fig 9 Shutdown Regulator

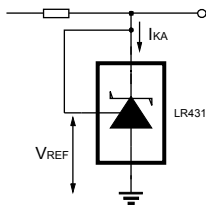
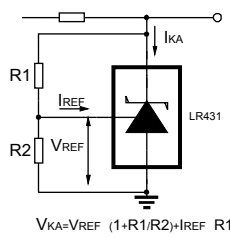
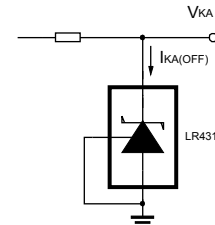
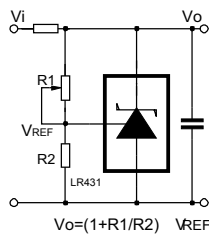
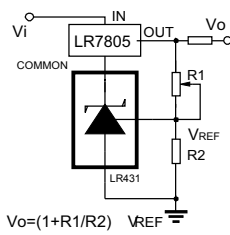

Fig 10 Output Control of a Three-Terminal Fixed Regulator

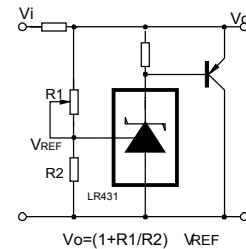

Fig 11 Higher-current Shunt Regulator

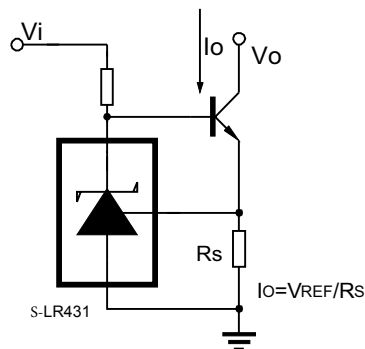

Fig 12 Constant-current Sink

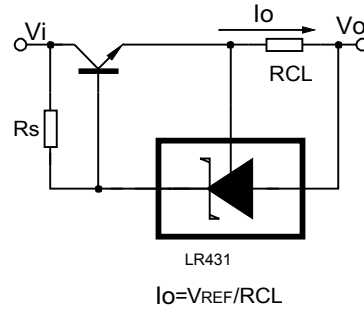
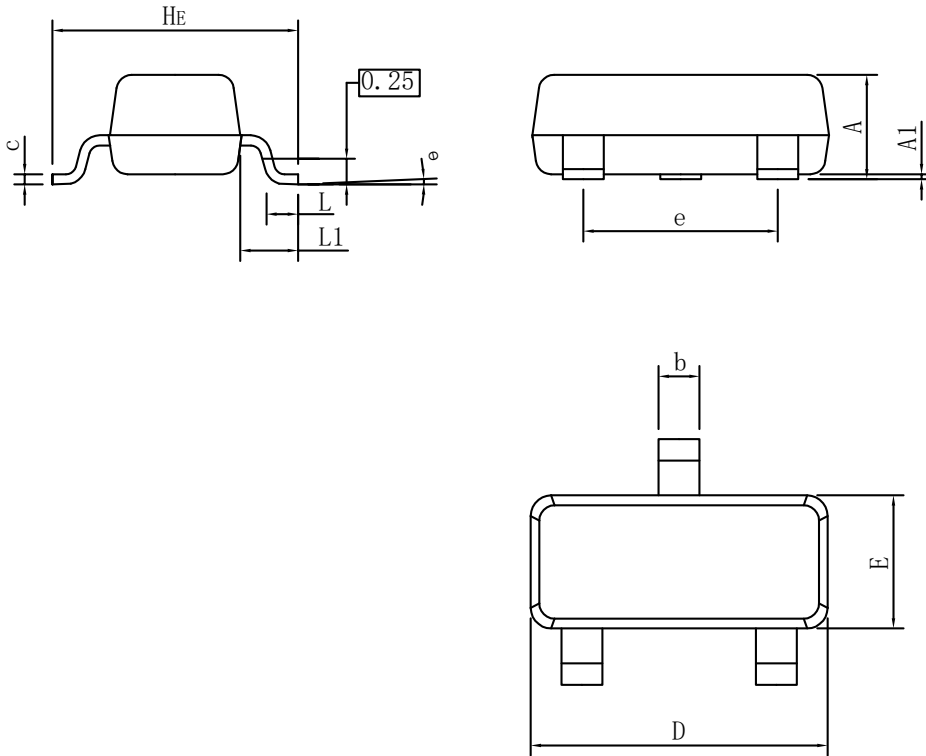

Fig 13 Current Limiting or Current Source

SOT-23 PACKAGE OUTLINE DIMENSIONS

SOT23E			
DIM	MIN	NOR	MAX
A	0.90	1.00	1.10
A1	0.01	0.06	0.10
b	0.30	0.40	0.50
c	0.10	0.17	0.20
D	2.80	2.90	3.00
E	1.20	1.30	1.40
e	1.80	1.90	2.00
L	0.20	0.40	0.60
L1	0.60REF		
HE	2.20	2.40	2.60
θ	0°	-	10°
All Dimensions in mm			

GENERAL NOTES

1. Top package surface finish Ra0.4±0.2um
2. Bottom package surface finish Ra0.7±0.2um
3. Side package surface finish Ra0.4±0.2um

X-ON Electronics

Largest Supplier of Electrical and Electronic Components

Click to view similar products for [Voltage References](#) category:

Click to view products by [Leshan](#) manufacturer:

Other Similar products are found below :

[5962-8686103XC](#) [LT1460GIZ-5PBF](#) [LT1009IZPBF](#) [NCV431BVDMR2G](#) [REF01J/883](#) [SC431ILPRAG](#) [AP432AQG-7](#) [LM4040B25QFTA](#)
[TL431BL3T](#) [BR431M](#) [MC1403BM/TR](#) [HT431BRZ](#) [ME4315AM6G-2](#) [ME4315AM6G-1](#) [TL431A-YK](#) [TL431](#) [TL431-1](#) [TL431](#) [TL431](#)
[XC6206P332MR](#) [HT431CRZ](#) [LM285M-1.2/TR](#) [S-LR431AKLT1G](#) [LR431AKLT1G](#) [LTL432ATLT1G](#) [TL431](#) [TP431CS3-1](#)
[LTL431APTSLT1G](#) [TP431CS3](#) [TL432](#) [TPR3530-S3TR](#) [LM236M-5.0/TR](#) [HT431ARZ](#) [TL431ACZ](#) [KA431SLMF2TF](#) [KA431SMF2TF](#)
[KA431SMFTF](#) [LM4040QCEM3-3.0/NOPB](#) [LM4041C12ILPR](#) [LM4050AIM3X-5.0/NOPB](#) [LM4120AIM5-2.5/NOP](#) [LM431SCCMFX](#)
[ZXRE250BSA-7](#) [ZXRE125DN8TA](#) [TS3330AQPR](#) [ZXRE250ASA-7](#) [ZTL431ASE5TA](#) [REF3012AIDBZR](#) [LM385BM-2.5/NOPB](#) [LM385D-](#)
[2.5R2G](#)