

SODSF11-SH thru SODSF18-SH

Surface Mount Glass Passivated Junction Fast Recovery Rectifiers

Reverse Voltage 50 to 600V Forward Current 1.0A

FEATURES

- * Plastic package has Underwriters Laboratory Flammability Classification 94V-0
- * High temperature metallurgically bonded construction
- * Cavity-free glass passivated junction
- * Capable of meeting environmental standards of MIL-S-19500
- * Typical IR less than 1.0 μ A
- * High temperature soldering guaranteed: 260°C/10 seconds

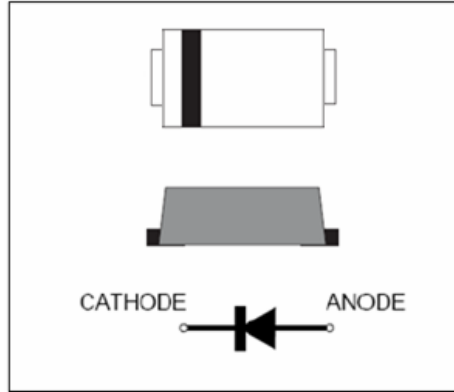

Mechanical Data

Case: JEDEC SOD123-FL/MINI SMA, molded plastic over glass DIE

Terminals: Tin Plated, solderable per MIL-STD-750, Method 2026

Polarity: Color band denotes cathode end

Mounting Position: Any

Weight: 0.0155 g

Handling precaution: None

We declare that the material of product is Halogen free (green epoxy compound)

Electrical Characteristic

1. Maximum & Thermal Characteristics Ratings at 25°C ambient temperature unless otherwise specified.

Parameter Symbol	symbol	SOD SF11-SH	SOD SF12-SH	SOD SF13-SH	SOD SF14-SH	SOD SF15-SH	SOD SF16-SH	SOD SF17-SH	SOD SF18-SH	Unit
Device marking code		SF11	SF12	SF13	SF14	SF15	SF16	SF17	SF18	
Maximum repetitive peak reverse voltage	V_{RRM}	50	100	150	200	300	400	500	600	V
Maximum RMS voltage	V_{RMS}	35	70	105	140	210	280	350	420	V
Maximum DC blocking voltage	V_{DC}	50	100	150	200	300	400	500	600	V
Maximum average forward rectified current lead length at $T_C = 75^\circ\text{C}$ (Note 2)	$I_{F(AV)}$	1.0								A
Peak forward surge current 8.3ms single half sine-wave superimposed on rated load (JEDEC Method)	I_{FSM}	30								A
Typical reverse recovery time (Note 1)	trr	35								ns
Typical thermal resistance (Note 2)	$R_{\theta JA}$ $R_{\theta JC}$	110 40								$^\circ\text{C/W}$
Operating junction temperature range	T_J	-55 to +150								$^\circ\text{C}$
storage temperature range	T_{STG}	-65 to +175								$^\circ\text{C}$

Electrical Characteristics Ratings at 25°C ambient temperature unless otherwise specified.

Parameter Symbol	symbol	SOD SF11-SH	SOD SF12-SH	SOD SF13-SH	SOD SF14-SH	SOD SF15-SH	SOD SF16-SH	SOD SF17-SH	SOD SF18-SH	Unit
Maximum instantaneous forward voltage at 1.0A	V_F	0.95			1.25		1.7			V
Maximum DC reverse current at rated DC blocking voltage $T_A = 25^\circ\text{C}$ $T_J = 100^\circ\text{C}$	I_R	5.0				100				μA
Typical junction capacitance at 4.0V, 1MHz (Note 2)	C_J	15.0								PF

NOTES:

1. $I_F = 0.5\text{A}$, $I_R = 1.0\text{A}$, $I_{RR} = 0.25\text{A}$
2. 8.0mm² (.013mm thick) land areas

SODSF11-SH thru SODSF18-SH

2. Characteristic Curves (TA = 25°C unless otherwise noted)

Fig. 1 – Forward Current Derating Curve

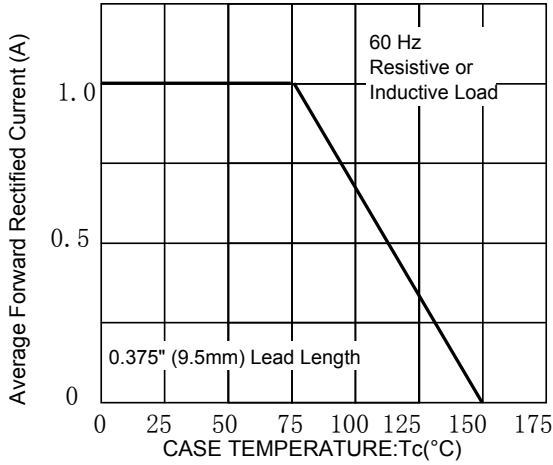

Fig. 2 – Maximum Non-repetitive Peak Forward Surge Current

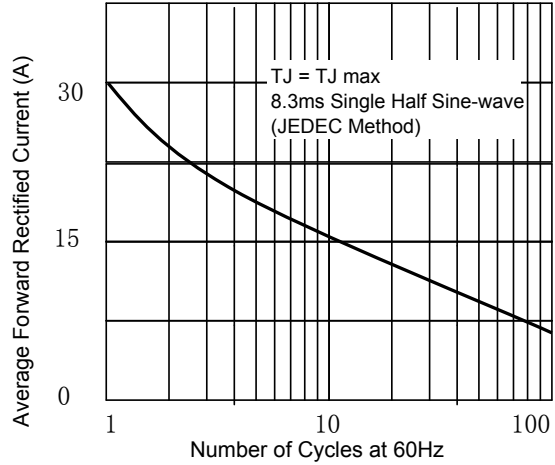

Fig 3. – Typical Instantaneous Forward Characteristics

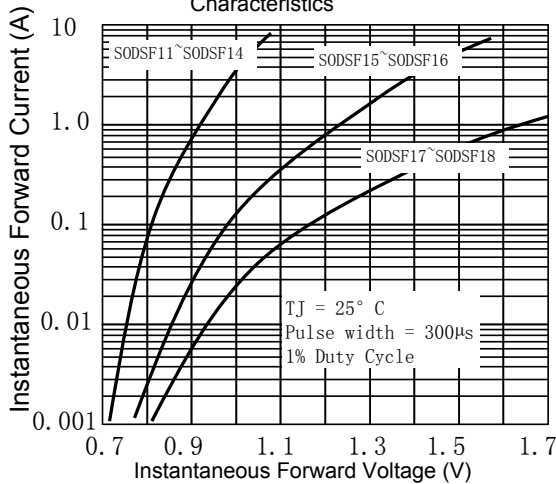

Fig 4. – Typical Reverse Characteristics

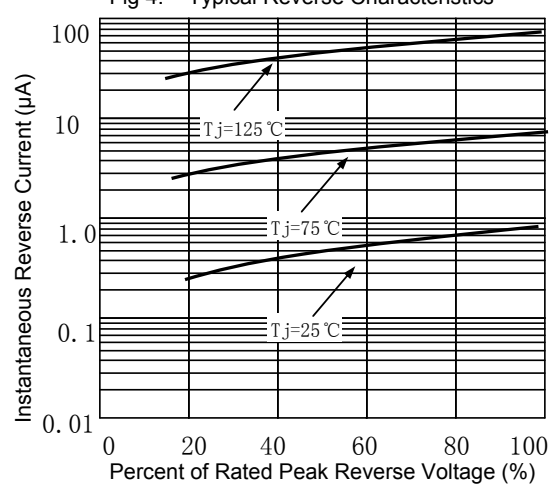

Fig 5. –typical transient thermal impedance

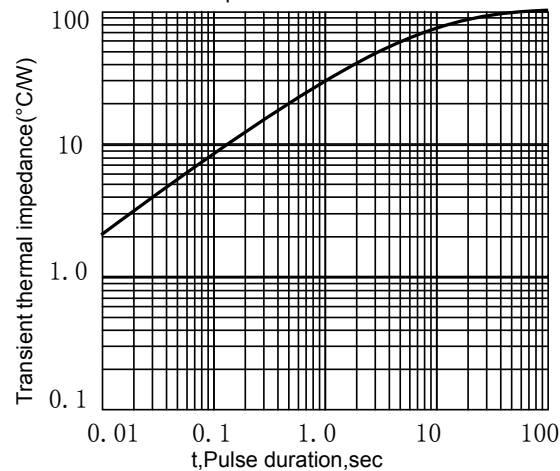
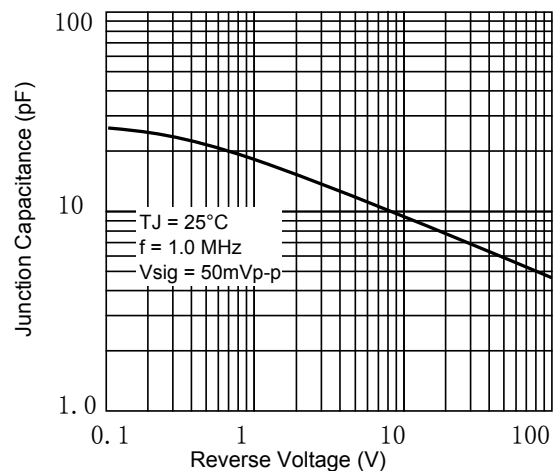
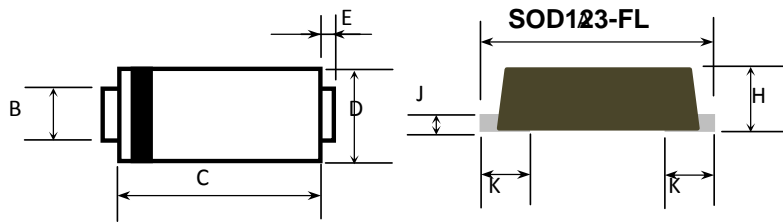

Fig 6. – Typical Junction Capacitance



SODSF11-SH thru SODSF18-SH

3. dimension:



DIM	MILLIMETERS		INCHES	
	MIN	MAX	MIN	MAX
A	3.5	3.9	0.138	0.159
B	0.75	0.95	0.029	0.037
C	2.6	3.0	0.103	0.119
D	1.6	2.0	0.063	0.079
E	0.45Typ		0.018Typ	
H	0.9	1.2	0.036	0.047
J	0.12	0.22	0.005	0.009
K	0.8Typ		0.032Typ	

Suggested solder pad layout

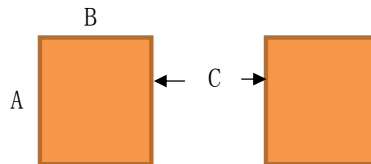

Dimensions in inches and (millimeters)

PACKAGE	A	B	C
SOD123-FL	0.044(1.10)	0.040(1.00)	0.079(2.00)

5.1 、 SMD Packing Reel Spec & Packing Quantity

5.1.1 Reel Packing
A. Reel Spec

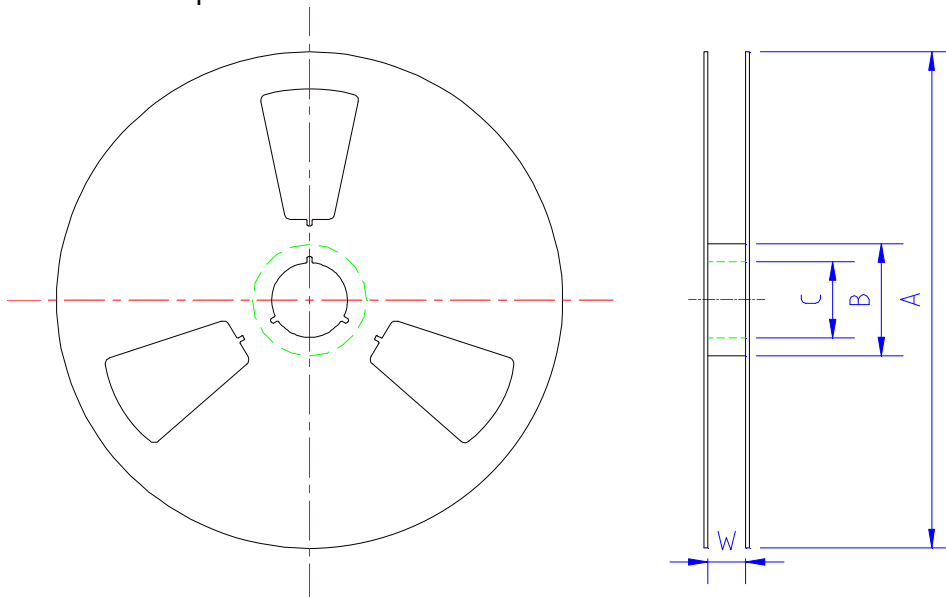

unit: mm

SPEC	A	B	C	W	Quantity/Reel
SMA 7" reel	177.0±2.0	54.0±0.5	13.0±0.5	13.2±0.2	2K
SMA13" reel	330.0±2.0	75.0±0.5	13.0±0.5	13.2±0.2	5K
SMA-FL13" reel	330.0±2.0	75.0±0.5	13.0±0.5	13.2±0.2	5K
TO277 13" reel	330.0±2.0	75.0±0.5	13.0±0.5	13.2±0.2	5K
SOD123FL 7" reel	177.0±2.0	50.0±0.5	13.0±0.5	9.4±1.5	3K
SOD323HE 7" reel	177.0±2.0	50.0±0.5	13.0±0.5	9.4±1.5	3K
SMB-FL 13" reel	330.0±2.0	75.0±0.5	13.0±0.5	13.2±0.2	5K

B. 13" reel packing box

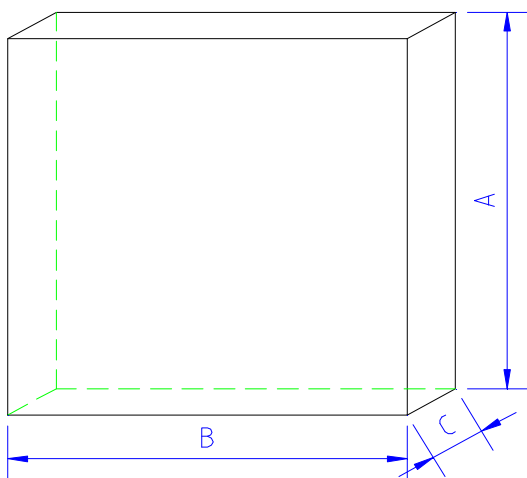

unit: mm

size	A	B	C
	335±5.0	335±2.0	40±1.0

as per above packing

Spec	Q' ty/Box
SMA13" reel	10K
TO277 13" reel	10K
SMB-FL 13" reel	10K

C. 7" reel packing box

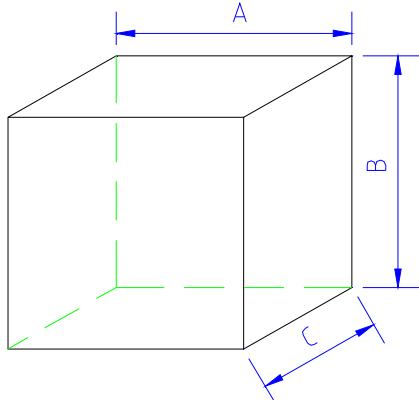

unit: mm

	A	B	C
SMA/SMA-FL	188±2.0	188±2.0	138±2.0
SOD123FL SOD323HE	186±2.0	139±2.0	185±2.0

as per above packing

	Q' ty/Box
SMA/SMA-FL	16K
SOD123FL	30K
SOD323HE	30K

D. reel packing carton

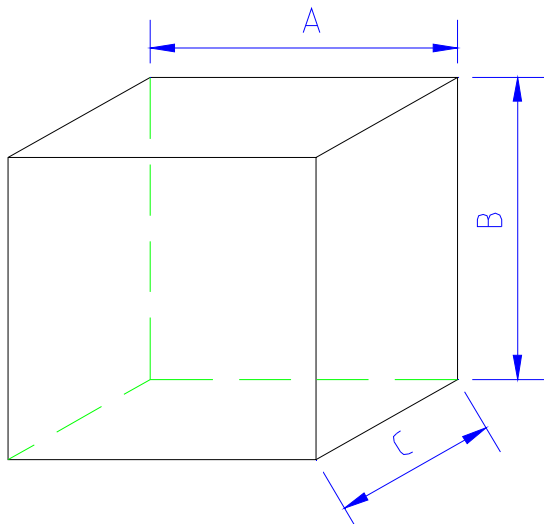

unit: mm

	A	B	C
size	350±2.0	340±2.0	350±2.0

as per above packing

Spec	Q' ty/Carton
SMA/SMA-FL 7" reel	80K
SMA13"reel	80K
SMA-FL13"reel	80K
TO277 13" reel	80K
SMB-FL 13" reel	80K

unit: mm

	A	B	C
SOD123FL SOD323HE	455±2.0	400±2.0	410±2.0

as per above packing

Spec	Q' ty/Carton
SOD123-FL 7" reel	360K
SOD323HE 7" reel	360K

5.1.2 Tape Spec

A. Cover Tape



unit: mm

	A	B
SMA /SMA-FL SMB-FL /TO277	9.5±0.10	0.062±0.007
SOD123FL SOD323HE	5.4±0.10	

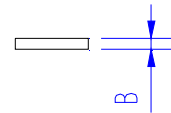

5.2、SMD Power Diode General Packing Spec

A. 7" reel all labels will be at cathode side of reel ;

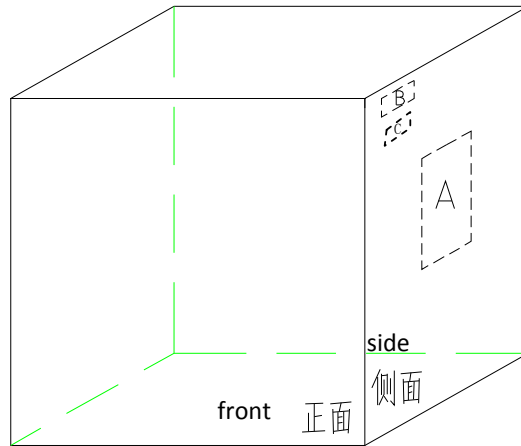

A:LRC label;

B:Environment Label C:Halide free label

B. 13" reel

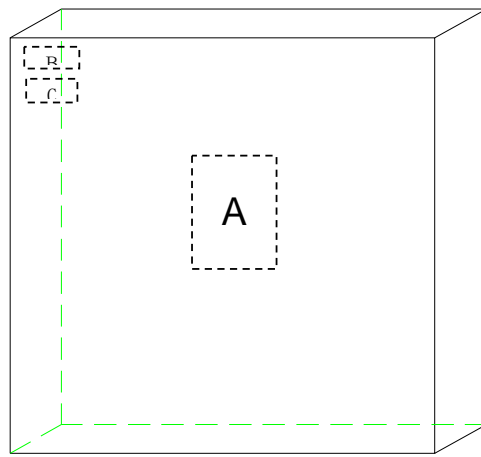

A:LRC label;

B:Environment Labe C:Halide free label

C. Tape lead: face anode side of the reel, upper side is the tape lead position. All labels are at cathode side of the reel.



标题:

Power Diode SMD Package Packing Spec

DOC NO.: WI-258

Version: 5 Modification: 0

Page: 6

C. Label Content :
LRC Label

P/N → (1P) LPN: SM140A
Lot No. → (1T) LOT: 140106049X
Date code → (9D) DTE: 1403
Quantity → (Q) QTY: 10000

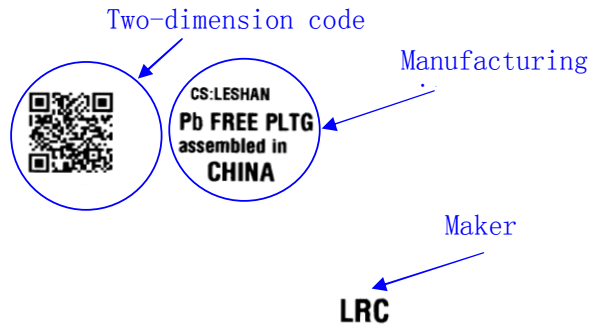

lot: 140106049X: 140106---2014/1/6; 049----lot number:49; X: product code

Environment Label



Halide-free Label



SODSF11-SH thru SODSF18-SH

Reel packing

PACKAGE	REEL SIZE	REEL (PCS)	COMPONENT SPACING (mm)	BOX (pcs)	INNER BOX (mm)	REEL DIA. (mm)	CARTON SIZE (mm)	CARTON (PCS)	APPOX. GROSS WEIGHT (kg)
SOD123-FL	7"	3,000	4.0	30,000	183*183*123	178	382*262*387	240,000	8.7

5.Suggested thermal profile for soldering process

1. Storage environment : Temperature=5~40°C Humidity=55±25%
2. Reflow soldering of surface-mount device

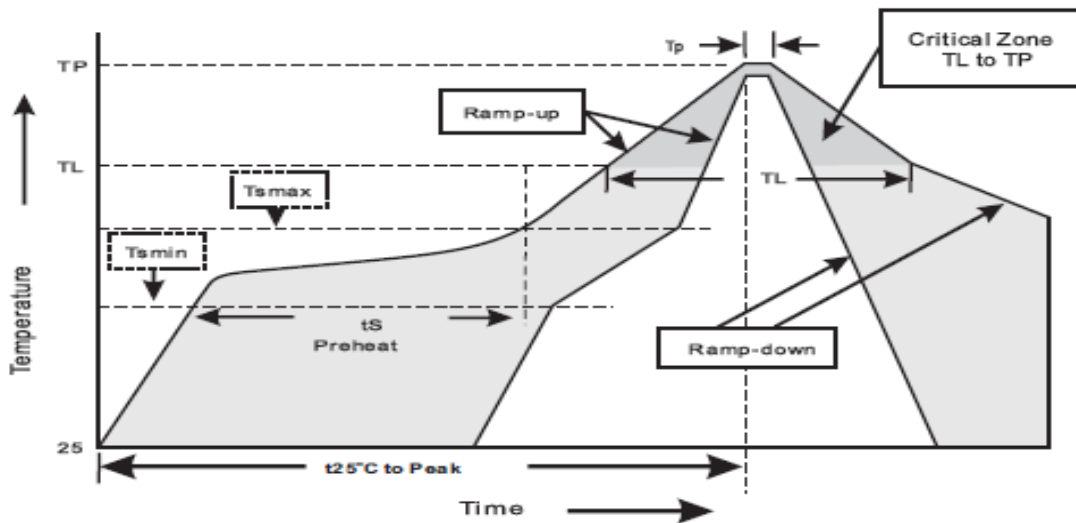

3. Reflow soldering

Profile Feature	Soldering Condition
Average ramp-up rate(T _L to T _P)	<3°C/sec
Preheat - Temperature Min(T _{Smin}) - Temperature Max(T _{Smax}) - Time(min to max)(t _S)	150°C 200°C 60~120sec
T _{Smax} to T _L - Ramp-up Rate	<3sec
Time maintained above: - Temperature (T _L) - Time(t _L)	217°C 60-260sec
Peak Temperature(T _P)	255 -0/+5°C
Time within 5°C of actual Peak Temperature(T _P)	10~30sec
Ramp-down Rate	<6°C/sec
Time 25°C to Peak Temperature	<6minutes

SODSF11-SH thru SODSF18-SH

6.High reliability test capabilities

Item Test	Condition	Reference
Solder Resistance	at 260±5°C for 10±2sec immerse body into solder 1/16" ± 1/32"	MIL-STD-750D METHOD-2031
Solderability	at 245±5°C for 5 sec	MIL-STD-202F METHOD-208
High Temperature Reverse Bias	VR=80% rate at T _j =150°C for 168hrs	MIL-STD-750D METHOD-1038
Forward Operation Life	Rated average rectifier current T _A =25°C for 500hrs	MIL-STD-750D METHOD-1027
Intermittent Operation Life	T _A =25°C , I _F =I _o On state:power on for 5 min. Off state:power off for 5 min. on and off for 500 cycles	MIL-STD-750D METHOD-1036
Pressure Cooker	15P _{SIG} at T _A =121°C for 4hrs	JESD22-A102
Temperature Cycling	-55°C to +125°C dwelled for 30 min. and transferred for 5min. Total 10 cycles	MIL-STD-750D METHOD-1051
Thermal Shock	0°C for 5min. Rise to 100°C for 5min. Total 10 cycles	MIL-STD-750D METHOD-1056
Forward Surge	8.3ms single half sine-wave superimposed on rated load,one surge	MIL-STD-750D METHOD-4066-2
Humidity	at T _A =85°C , RH=85% for 1000hrs	MIL-STD-750D METHOD-1021
High Temperature Storage Life	at 175°C for 1000hrs	MIL-STD-750D METHOD-1031

SODSF11-SH thru SODSF18-SH

7. Update Record

版次	更新记录	更新作者	更新日期
1	第一版	周杰	2013.07.05

X-ON Electronics

Largest Supplier of Electrical and Electronic Components

Click to view similar products for [Rectifiers](#) category:

Click to view products by [Leshan](#) manufacturer:

Other Similar products are found below :

[D91A](#) [DA24F4100L](#) [DD89N1600K-A](#) [DD89N16K-K](#) [RL252-TP](#) [DLA11C-TR-E](#) [DSA17G](#) [DSEI2X30-06C](#) [1N4005-TR](#) [BAV199-TP](#)
[UFS120Je3/TR13](#) [JANS1N6640US](#) [VS-80-1293](#) [DD89N16K](#) [DD89N16K-A](#) [481235F](#) [DSP10G-TR-E](#) [067907F](#) [MS306](#) [ND104N08K](#)
[SPA2003-B-D-A01](#) [VS-80-6193](#) [VS-66-9903](#) [VGF0136AB](#) [US2JFL-TP](#) [UFS105Je3/TR13](#) [A1N5404G-G](#) [ACGRA4007-HF](#) [ACGRB207-HF](#)
[RF301B2STL](#) [RF501B2STL](#) [UES1306](#) [UES1302](#) [BAV199E6433HTMA1](#) [ACGRC307-HF](#) [ACEFC304-HF](#) [JANTXV1N5660A](#) [UES1106](#)
[GS2K-LTP](#) [D126A45C](#) [D251N08B](#) [SCHJ22.5K](#) [SM100](#) [SCPA2](#) [SCH10000](#) [SDHD5K](#) [STTH20P035FP](#) [VS-8EWS12S-M3](#) [VS-](#)
[12FL100S10](#) [ACGRA4001-HF](#)