

**General Description:**

The LWN1H5290A4 uses trench technology and design to provide excellent  $R_{DS(ON)}$  with low gate charge. It can be used in a wide variety of applications. The package form is TO-252, which accords with the ROHS standard and Halogen Free standard.

**Features:**

- Fast Switching
- Low Gate Charge and  $R_{DS(ON)}$
- Low Reverse transfer capacitances

**Applications:**

- DC-DC Converter
- Portable Equipment
- Power Management

**100% DVDS Tested**

**100% Avalanche Tested**

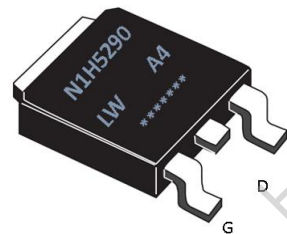
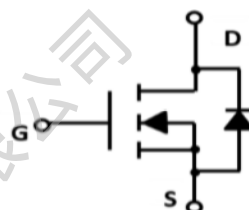

$V_{DSS}$	150	V
$I_D$	10	A
$P_D$	30	W
$R_{DS(ON)}$ TYPE	240	m $\Omega$

**Marking and Pin Assignment**

**Inner Equivalent Principium Chart**

**Package Marking and Ordering Information:**

Marking	Part Number	Package	Packing	Qty.
N1H5290/LW A4/D.C.	LWN1H5290A4	TO-252	Reel	2500 Pcs

**Absolute Maximum Ratings:**

Symbol	Parameter	Value	Units
$V_{DSS}$	Drain-to-Source Voltage	150	V
$I_D$	Continuous Drain Current	$T_C=25^\circ\text{C}$	10
	Continuous Drain Current	$T_C=100^\circ\text{C}$	6.3
$I_{DM}^{a1}$	Pulsed Drain Current	40	A
$E_{AS}^{a2}$	Single pulse avalanche energy	28.8	mJ
$V_{GS}$	Gate-to-Source Voltage	$\pm 20$	V
$P_D$	Power Dissipation	30	W
$T_J, T_{STG}$	Operating Junction and Storage Temperature Range	150, -55 to 150	$^\circ\text{C}$
$T_L$	Maximum Temperature for Soldering	260	$^\circ\text{C}$

**Thermal Characteristics:**

Symbol	Parameter	Value	Units
$R_{\theta JC}$	Thermal Resistance, Junction-to-Case	4.16	$^\circ\text{C}/\text{W}$
$R_{\theta JA}$	Thermal Resistance, Junction-to-Ambient	65	$^\circ\text{C}/\text{W}$

**Electrical Characteristic** ( $T_C = 25\text{ }^\circ\text{C}$ , unless otherwise specified):

Static Characteristics						
Symbol	Parameter	Test Conditions	Value			Units
			Min.	Typ.	Max.	
$V_{DSS}$	Drain to Source Breakdown Voltage	$V_{GS}=0V, I_D=250\mu A$	150	--	--	V
$I_{DSS}$	Drain to Source Leakage Current	$V_{DS}=150V, V_{GS}=0V$	--	--	1.0	$\mu A$
$I_{GSS(F)}$	Gate to Source Forward Leakage	$V_{GS}=+20V, V_{DS}=0V$	--	--	100	nA
$I_{GSS(R)}$	Gate to Source Reverse Leakage	$V_{GS}=-20V, V_{DS}=0V$	--	--	-100	nA
$V_{GS(TH)}$	Gate Threshold Voltage	$V_{DS}=V_{GS}, I_D=250\mu A$	1.4	1.9	2.4	V
$R_{DS(ON)}$	Drain-to-Source On-Resistance	$V_{GS}=10V, I_D=5.0A$	--	240	290	m $\Omega$

Dynamic Characteristics						
Symbol	Parameter	Test Conditions	Value			Units
			Min.	Typ.	Max.	
$C_{iss}$	Input Capacitance	$V_{GS} = 0V$	--	425	--	pF
$C_{oss}$	Output Capacitance	$V_{DS} = 75V$	--	17	--	
$C_{rss}$	Reverse Transfer Capacitance	$f = 1.0MHz$	--	11	--	
$R_G$	Gate resistance	$V_{GS}=0V, V_{DS}$ Short	--	1.36	--	$\Omega$

Resistive Switching Characteristics						
Symbol	Parameter	Test Conditions	Value			Units
			Min.	Typ.	Max.	
$t_{d(ON)}$	Turn-on Delay Time	$I_D = 1.0A$ $V_{DS} = 75V$ $V_{GS} = 10V$ $R_G = 5.0\Omega$	--	8.5	--	ns
$t_r$	Rise Time		--	10	--	
$t_{d(OFF)}$	Turn-Off Delay Time		--	21	--	
$t_f$	Fall Time		--	14.5	--	
$Q_g$	Total Gate Charge	$V_{GS} = 10V$	--	13.2	--	nC
$Q_{gs}$	Gate Source Charge	$V_{DS} = 75V$	--	2.39	--	
$Q_{gd}$	Gate Drain Charge	$I_D = 10A$	--	3.69	--	

Source-Drain Diode Characteristics						
Symbol	Parameter	Test Conditions	Value			Units
			Min.	Typ.	Max.	
$I_S$	Diode Forward Current	$T_C = 25\text{ }^\circ\text{C}$	--	--	10	A
$V_{SD}$	Diode Forward Voltage	$I_S = 5.0A, V_{GS} = 0V$	--	--	1.2	V

a1: Repetitive rating; pulse width limited by maximum junction temperature

a2:  $V_{DD} = 75V, L = 0.5mH, R_G = 25\Omega, \text{Starting } T_J = 25\text{ }^\circ\text{C}$

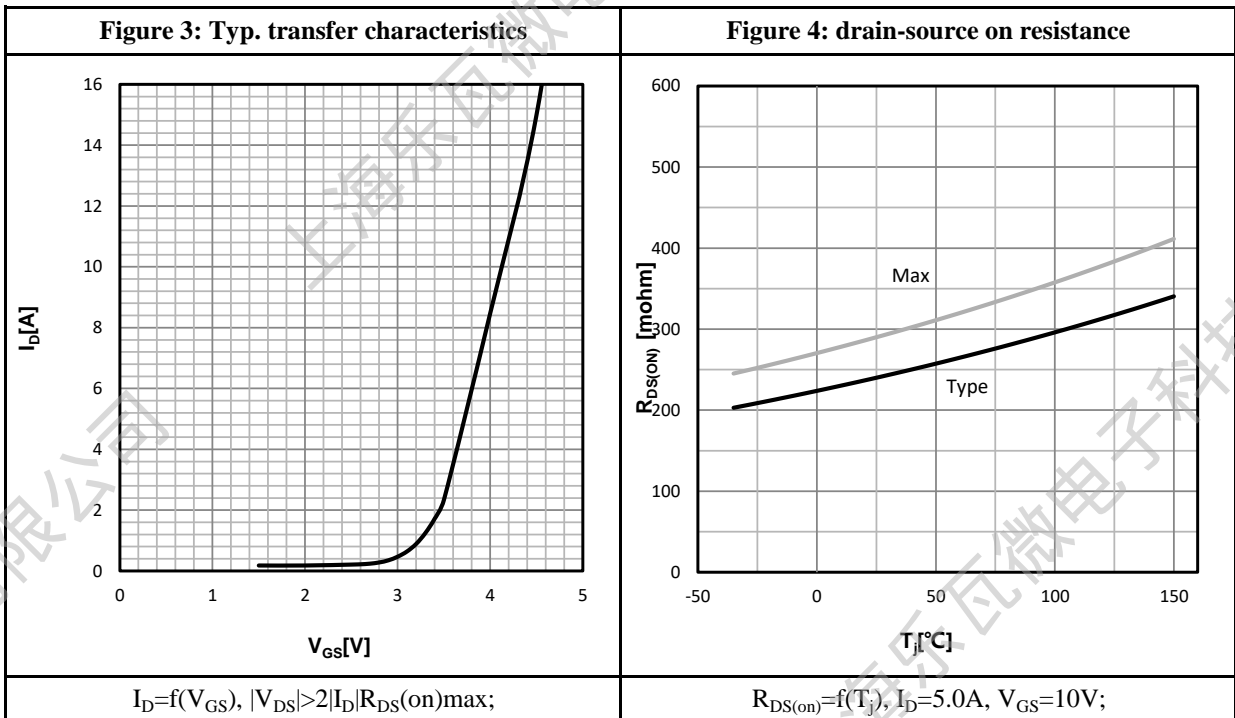
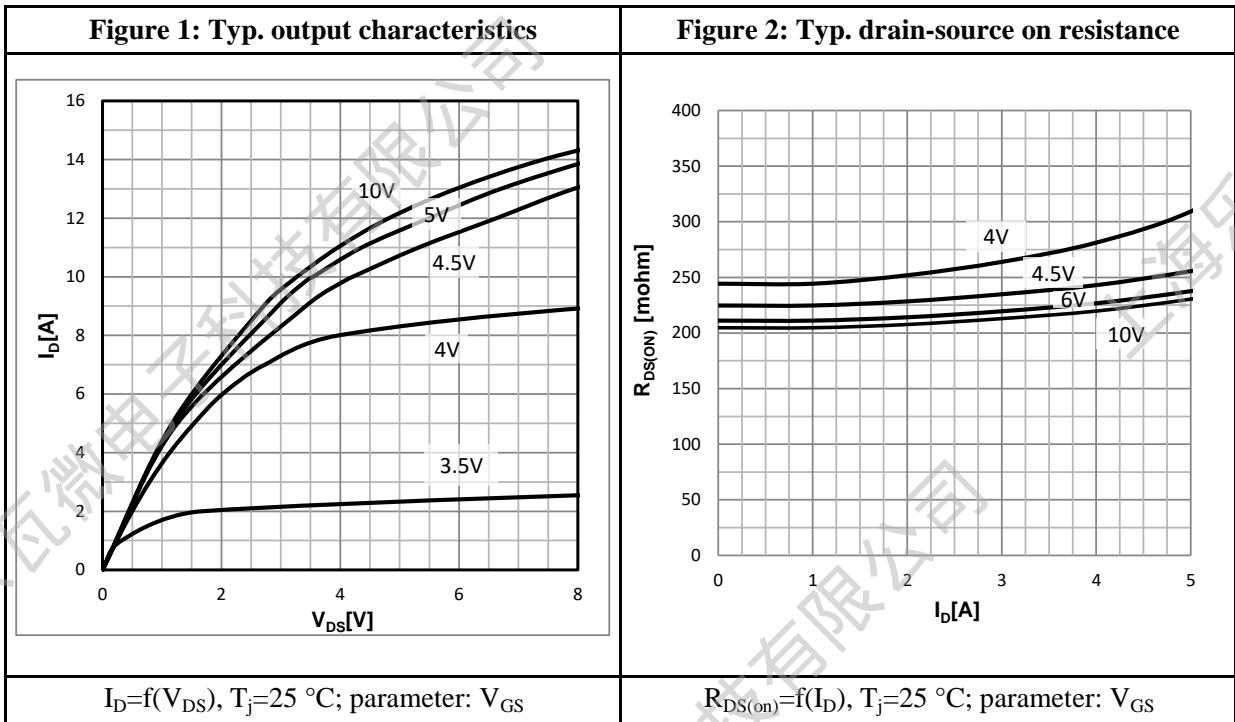
**Characteristics Curve:**

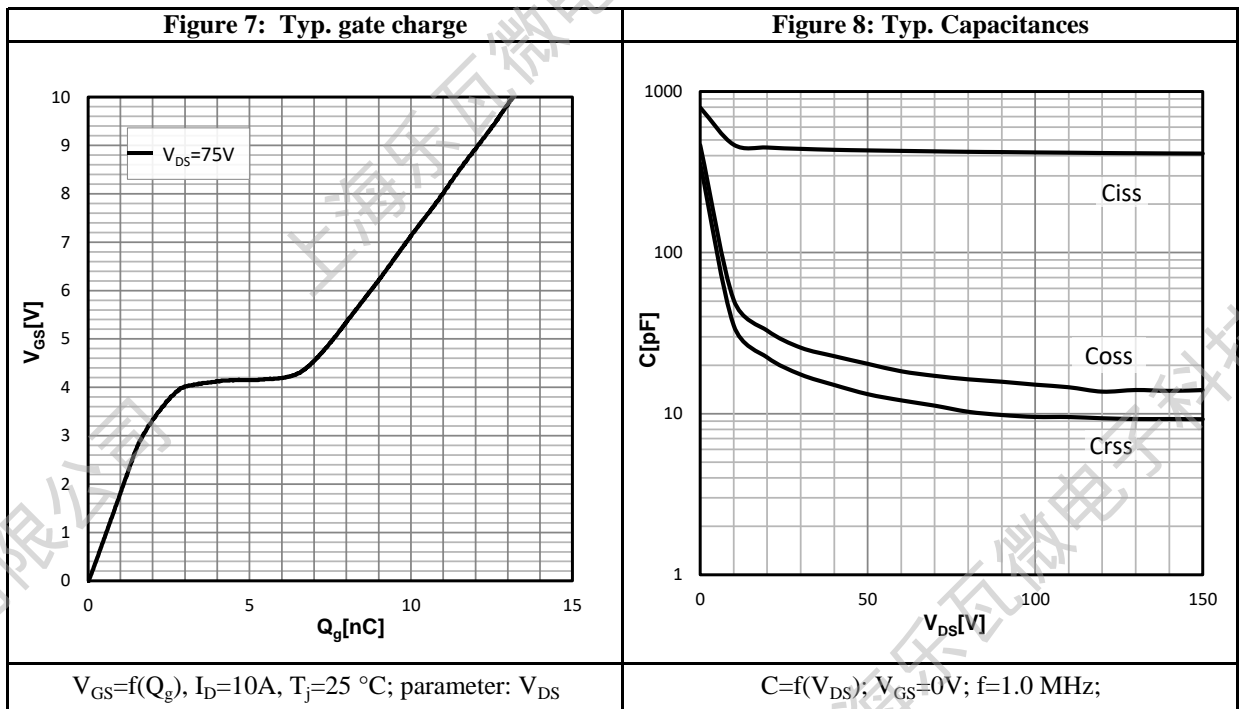
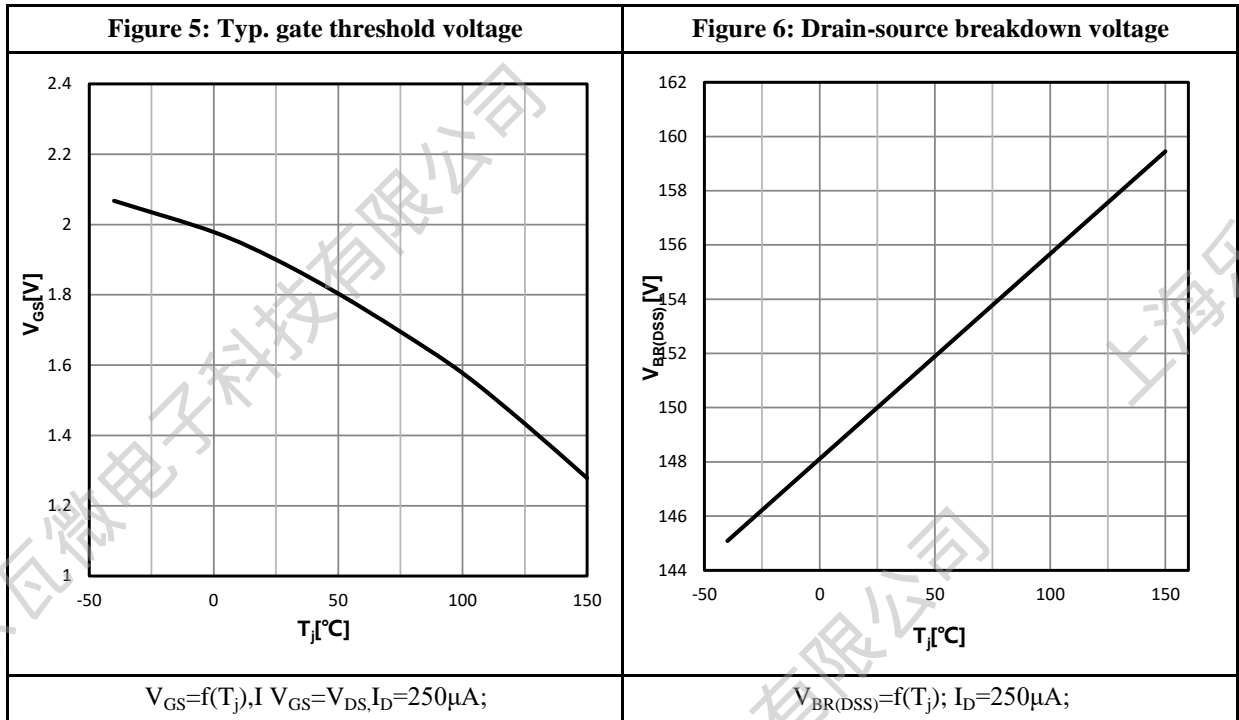

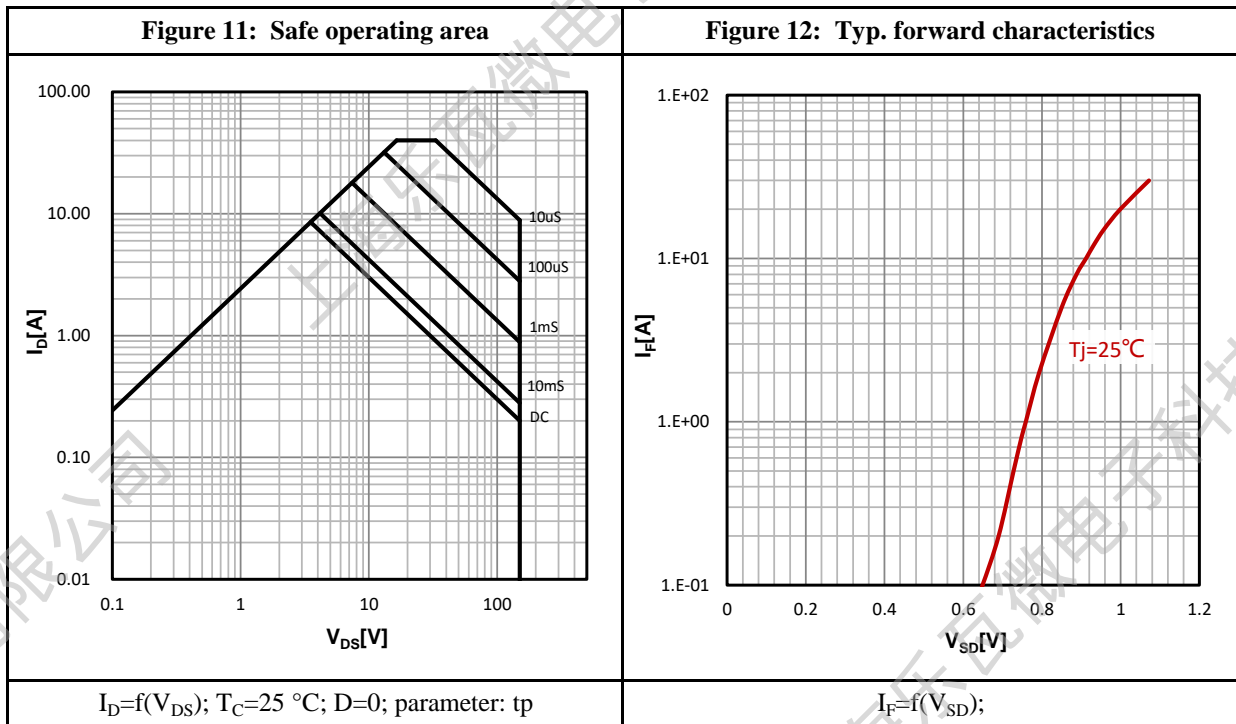
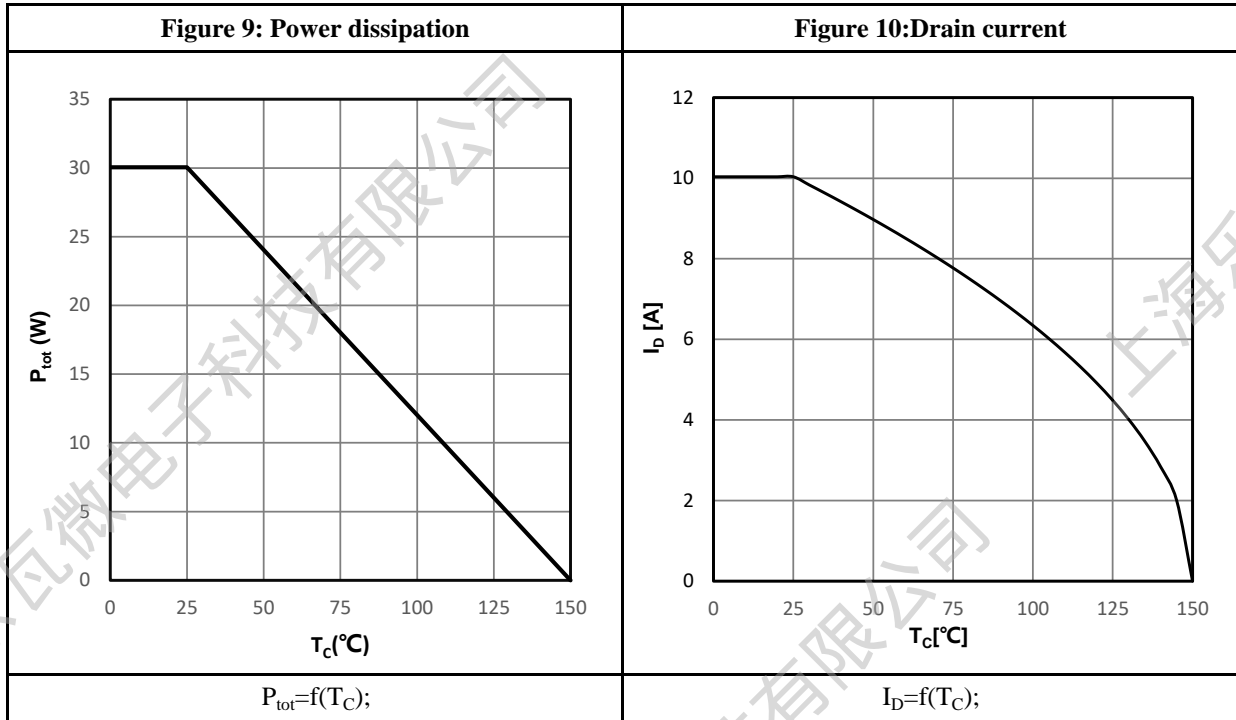

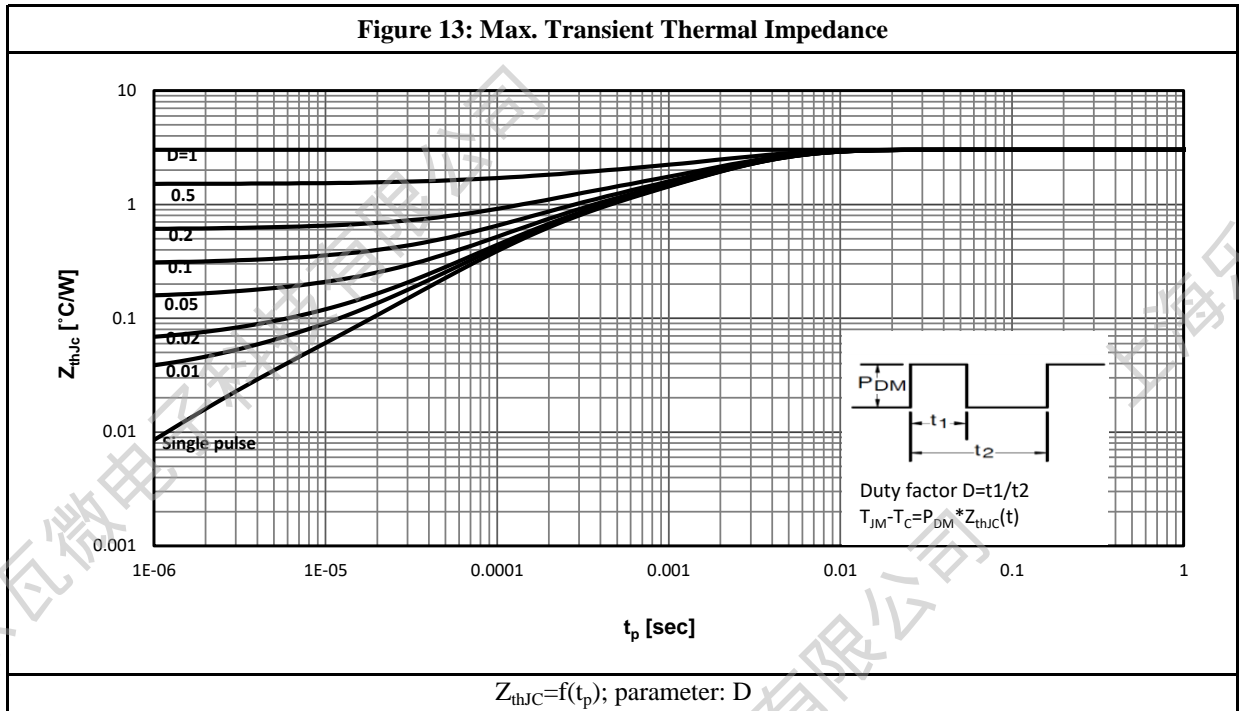

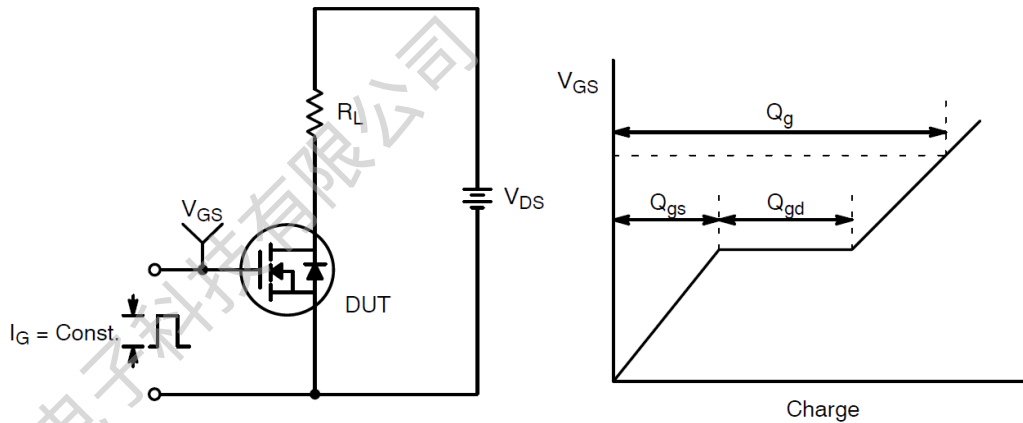
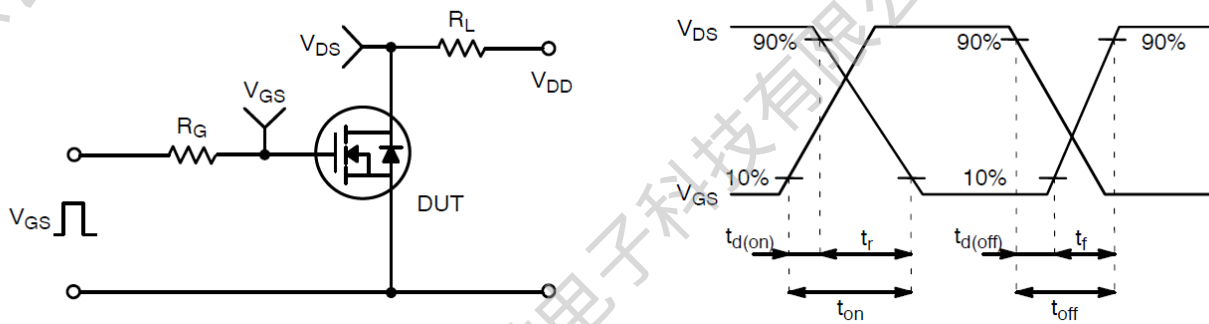
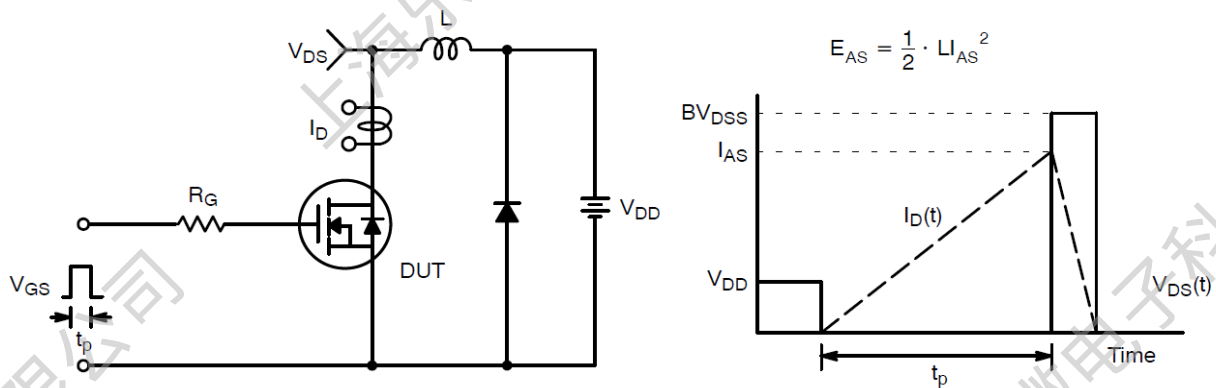
**Test Circuit & Waveform:**

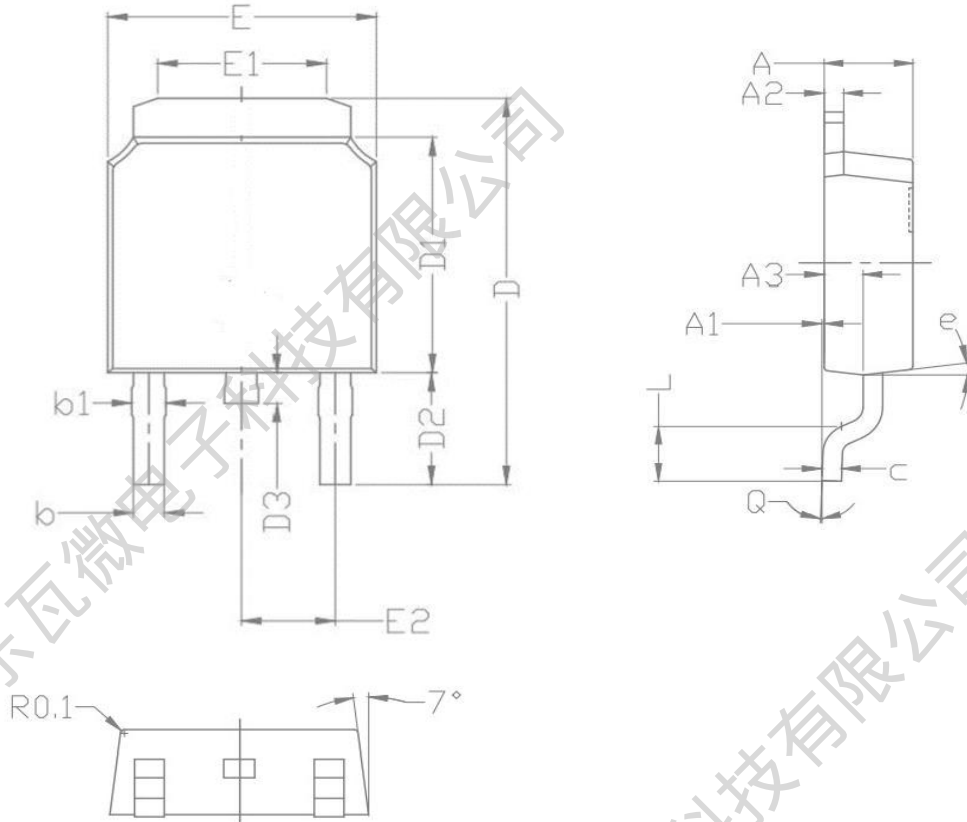
**Figure 14: Gate Charge Test Circuit & Waveform**

**Figure 15: Resistive Switching Test Circuit & Waveforms**

**Figure 16: Unclamped Inductive Switching Test Circuit & Waveforms**

**Package Outline:**

COMMON			
PKG	TO-252-2L		
Symbol	Min	Nom	Max
A	2.200	2.300	2.400
A1	0.000	0.075	0.150
A2	0.500	0.508	0.550
A3	0.960	1.010	1.060
b	0.740	0.760	0.800
b1	0.880	0.900	0.950
C	0.500	0.508	0.550
D	9.800	10.025	10.350
D1	6.050	6.100	6.180
D2	2.850	2.900	2.950
D3	0.600	0.800	1.000
E	6.550	6.600	6.700
E1	4.050	4.130	4.200
E2	2.25	2.286	2.3
L	1.400	1.500	1.600
e	7°		
Q	0°	2°	5°



**Revision History:**

<b>Revison</b>	<b>Date</b>	<b>Descriptions</b>
Rev 1.0	Feb.2024	Initial Version

**Disclaimer:**

The information in this document is believed to be accurate and reliable. However, no responsibility is assumed by LW-Micro for its use. All operating parameters must be designed, validated and tested to ensure they meet the requirements of your application. LW-Micro reserves the right to make any specification and/or circuitry changes without prior notification. Before starting a brand-new project, please contact LW-Micro Sales to get the most recent relevant information.

Mailing Address: Room 301, Building 2, No.1690 CaiLun Road, China (Shanghai) Pilot Free Trade Zone  
Shanghai Lewa Micro-electronics Technology Co., Ltd

## X-ON Electronics

Largest Supplier of Electrical and Electronic Components

*Click to view similar products for [MOSFET](#) category:*

*Click to view products by [Lewa Micro](#) manufacturer:*

Other Similar products are found below :

[IRFD120](#) [IRFY240C](#) [JANTX2N5237](#) [2SK2267\(Q\)](#) [BUK455-60A/B](#) [MIC4420CM-TR](#) [VN1206L](#) [NDP4060](#) [SI4482DY](#)  
[IPS70R2K0CEAKMA1](#) [SQD23N06-31L-GE3](#) [TK16J60W,S1VQ\(O](#) [2SK2614\(TE16L1,Q\)](#) [DMN1017UCP3-7](#) [EFC2J004NUZTDG](#)  
[DMN1053UCP4-7](#) [SQJ469EP-T1-GE3](#) [NTE2384](#) [DMC2700UDMQ-7](#) [DMN2080UCB4-7](#) [DMN61D9UWQ-13](#) [US6M2GTR](#)  
[DMN31D5UDJ-7](#) [DMP22D4UFO-7B](#) [DMN1006UCA6-7](#) [DMN16M9UCA6-7](#) [STF5N65M6](#) [IRF40H233XTMA1](#) [STU5N65M6](#)  
[DMN6022SSD-13](#) [DMN13M9UCA6-7](#) [DMTH10H4M6SPS-13](#) [DMN2990UFB-7B](#) [IPB80P04P405ATMA2](#) [2N7002W-G](#) [MCAC30N06Y-](#)  
[TP](#) [MCQ7328-TP](#) [NTMC083NP10M5L](#) [NVMFS2D3P04M8LT1G](#) [BXP7N65D](#) [BXP4N65F](#) [AOL1454G](#) [WMJ80N60C4](#) [BXP2N20L](#)  
[BXP2N65D](#) [BXT1150N10J](#) [BXT1700P06M](#) [TSM60NB380CP](#) [ROG](#) [RQ7L055BGTCR](#) [DMNH15H110SK3-13](#)