

General Description:

The LWS6080A23 uses advanced SGT technology and design to provide excellent $R_{DS(ON)}$ with low gate charge. It can be used in a wide variety of applications. The package form is SOT-223, which accords with the ROHS standard and Halogen Free standard.

Free standard.

Features:

- Fast Switching
- Low Gate Charge and $R_{DS(ON)}$
- Low Reverse transfer capacitances

Applications:

- Battery switching application
- Hard switched and high frequency circuits
- Power Management

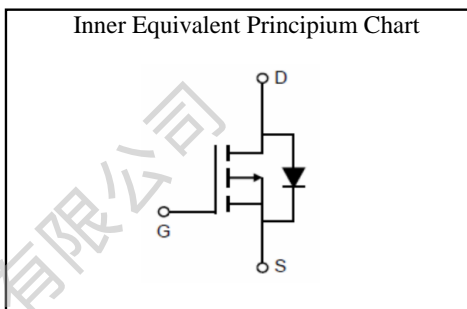
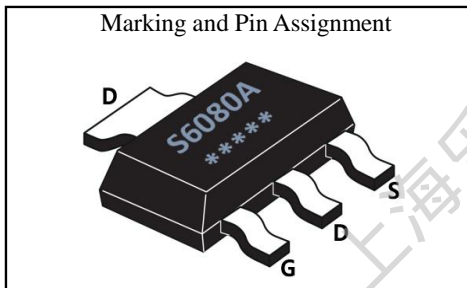

V_{DSS}	-60	V
I_D	-5.0	A
P_D	3.0	W
$R_{DS(ON)}$ TYPE	60	m Ω

Package Marking and Ordering Information:

Marking	Part Number	Package	Packing	Qty.
S6080A/D.C.	LWS6080A23	SOT-223	Reel	3000 Pcs

Absolute Maximum Ratings:

Symbol	Parameter	Value	Units
V_{DSS}	Drain-to-Source Voltage	-60	V
I_D	Continuous Drain Current	$T_C=25^\circ\text{C}$	-5.0
	Continuous Drain Current	$T_C=100^\circ\text{C}$	-3.1
I_{DM}^{al}	Pulsed Drain Current	-20	A
V_{GS}	Gate-to-Source Voltage	± 20	V
P_D	Power Dissipation	3.0	W
T_J, T_{STG}	Operating Junction and Storage Temperature Range	150, -55 to 150	$^\circ\text{C}$
T_L	Maximum Temperature for Soldering	260	$^\circ\text{C}$

Thermal Characteristics:

Symbol	Parameter	Value	Units
$R_{\theta JA}$	Thermal Resistance, Junction-to-Ambient	41.6	$^\circ\text{C}/\text{W}$

Electrical Characteristic ($T_A = 25\text{ }^\circ\text{C}$, unless otherwise specified):

Static Characteristics						
Symbol	Parameter	Test Conditions	Value			Units
			Min.	Typ.	Max.	
V_{DSS}	Drain to Source Breakdown Voltage	$V_{GS}=0V, I_D=-250\mu A$	-60	--	--	V
I_{DSS}	Drain to Source Leakage Current	$V_{DS}=-60V, V_{GS}=0V$	--	--	1.0	μA
$I_{GSS(F)}$	Gate to Source Forward Leakage	$V_{GS}=-20V, V_{DS}=0V$	--	--	100	nA
$I_{GSS(R)}$	Gate to Source Reverse Leakage	$V_{GS}=+20V, V_{DS}=0V$	--	--	-100	nA
$V_{GS(TH)}$	Gate Threshold Voltage	$V_{DS}=V_{GS}, I_D=-250\mu A$	-1.3	-1.65	-2.1	V
$R_{DS(ON)1}$	Drain-to-Source On-Resistance	$V_{GS}=-10V, I_D=-5.0A$	--	60	75	$m\Omega$
$R_{DS(ON)2}$	Drain-to-Source On-Resistance	$V_{GS}=-4.5V, I_D=-4.0A$	--	75	100	$m\Omega$

Dynamic Characteristics						
Symbol	Parameter	Test Conditions	Value			Units
			Min.	Typ.	Max.	
C_{iss}	Input Capacitance	$V_{GS} = 0V$	--	504	--	pF
C_{oss}	Output Capacitance	$V_{DS} = -30V$	--	82	--	
C_{riss}	Reverse Transfer Capacitance	$f = 1.0MHz$	--	3.9	--	
R_G	Gate resistance	$V_{GS}=0V, V_{DS}$ Open	--	3.0	--	Ω

Resistive Switching Characteristics						
Symbol	Parameter	Test Conditions	Value			Units
			Min.	Typ.	Max.	
$t_{d(ON)}$	Turn-on Delay Time	$I_D = -5A$	--	10	--	ns
t_r	Rise Time	$V_{DS} = -30V$	--	6.0	--	
$t_{d(OFF)}$	Turn-Off Delay Time	$V_{GS} = -10V$	--	40	--	
t_f	Fall Time	$R_G = 3\Omega$	--	13	--	
Q_g	Total Gate Charge	$V_{GS} = -10V$	--	10.5	--	nC
Q_{gs}	Gate Source Charge	$V_{DS} = -30V$	--	2.8	--	
Q_{gd}	Gate Drain Charge	$I_D = -5A$	--	1.5	--	

Source-Drain Diode Characteristics						
Symbol	Parameter	Test Conditions	Value			Units
			Min.	Typ.	Max.	
I_S	Diode Forward Current	$T_C = 25\text{ }^\circ\text{C}$	--	--	-5.0	A
I_{SM}	Diode Pulse Current		--	--	-20	A
V_{SD}	Diode Forward Voltage	$I_S = -5A, V_{GS} = 0V$	--	--	-1.2	V
t_{rr}	Reverse Recovery time	$I_S = -5A, V_{DD} = -30V,$	--	50	--	ns
Q_{rr}	Reverse Recovery Charge	$dI/dt = 100A/us$	--	105	--	nC

a1: Repetitive rating; pulse width limited by maximum junction temperature

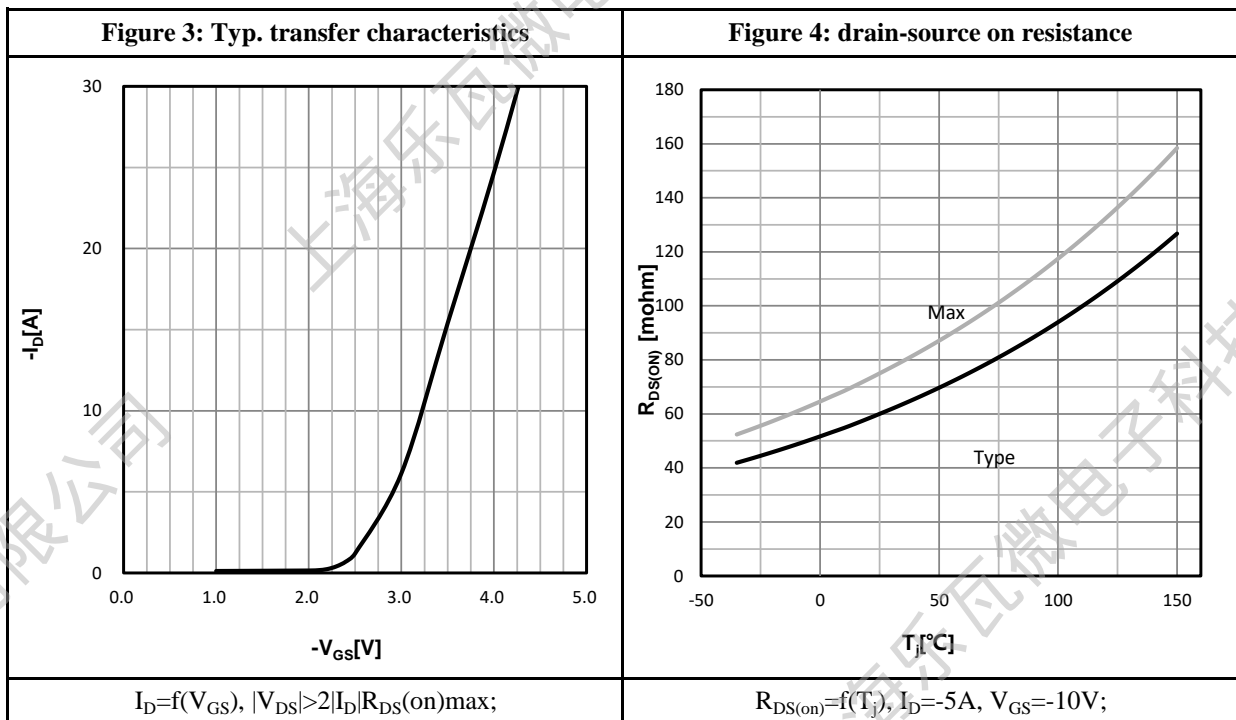
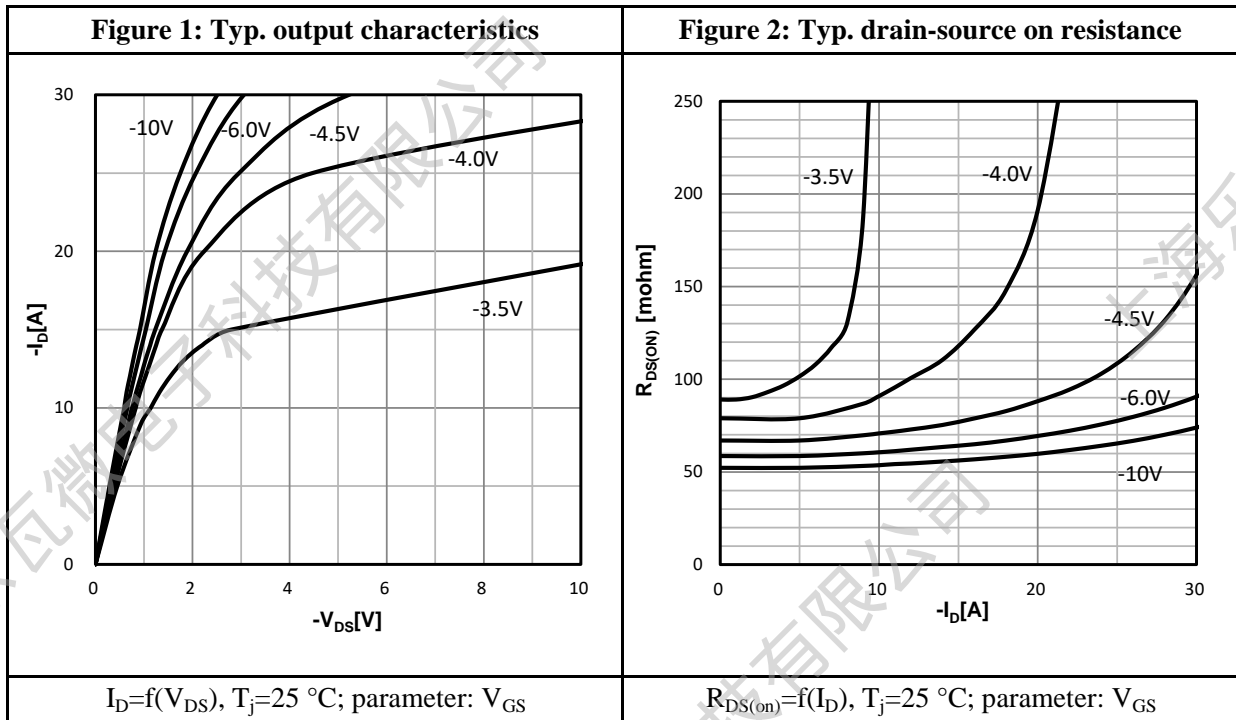
Characteristics Curve:

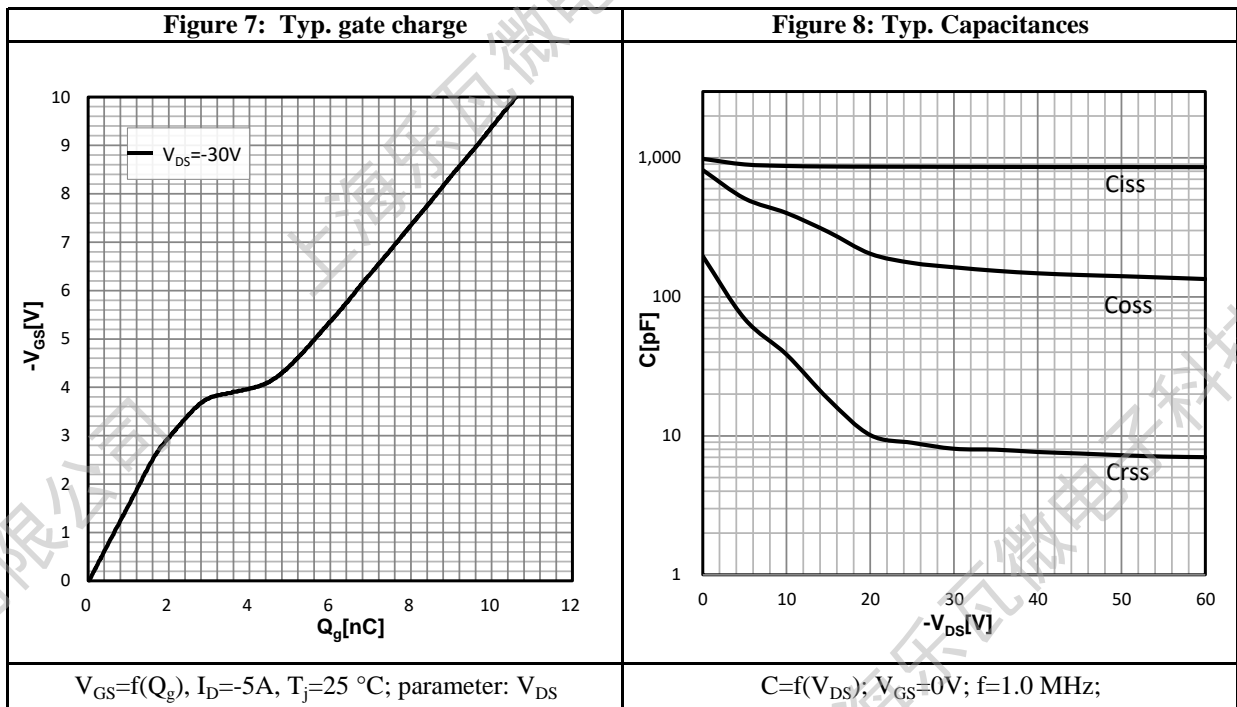
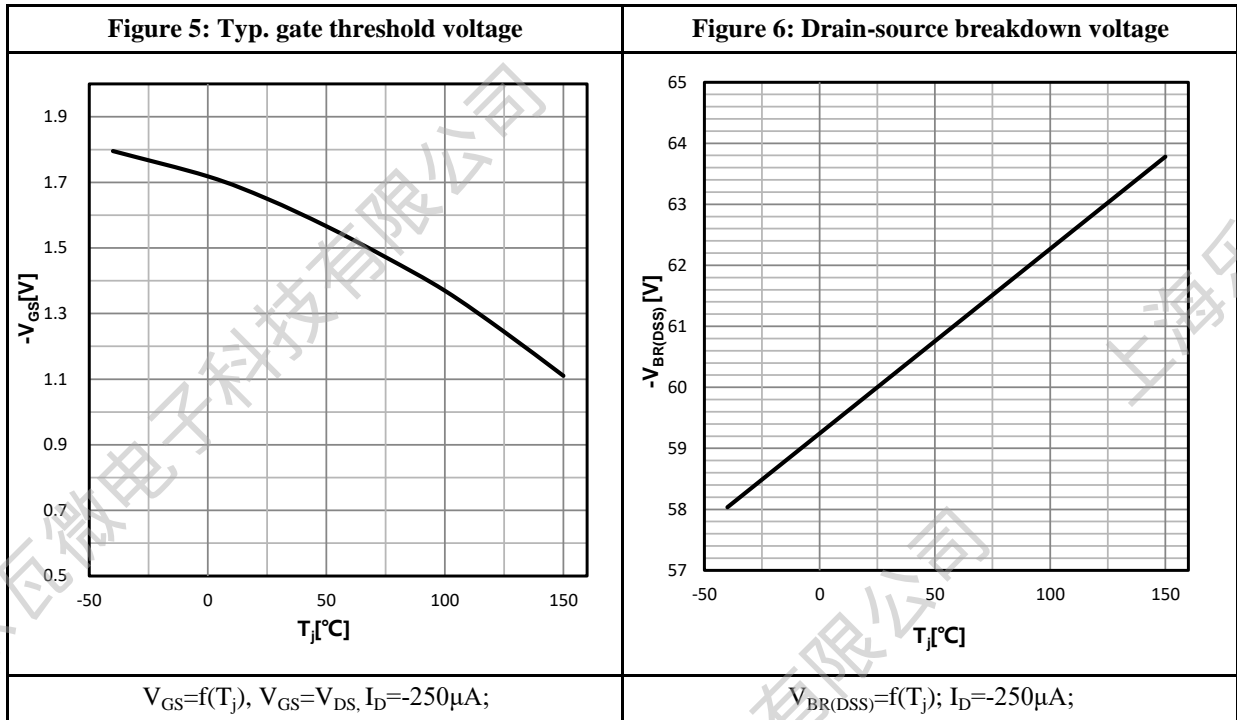

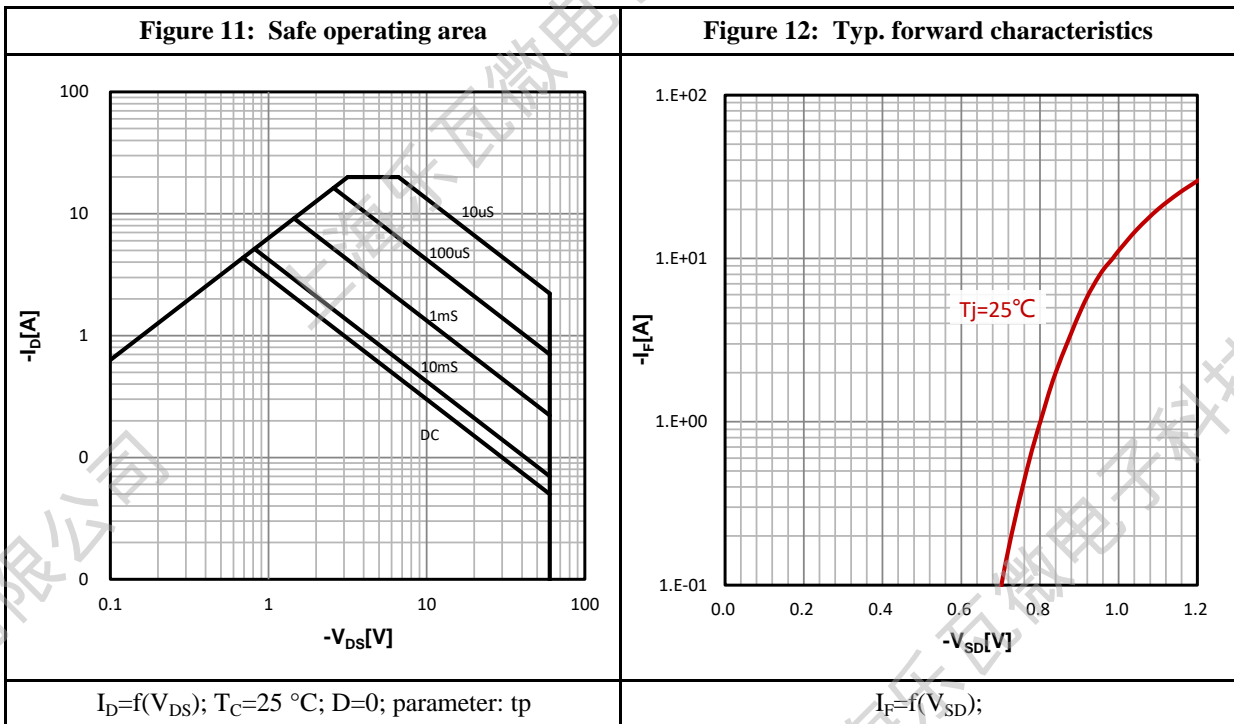
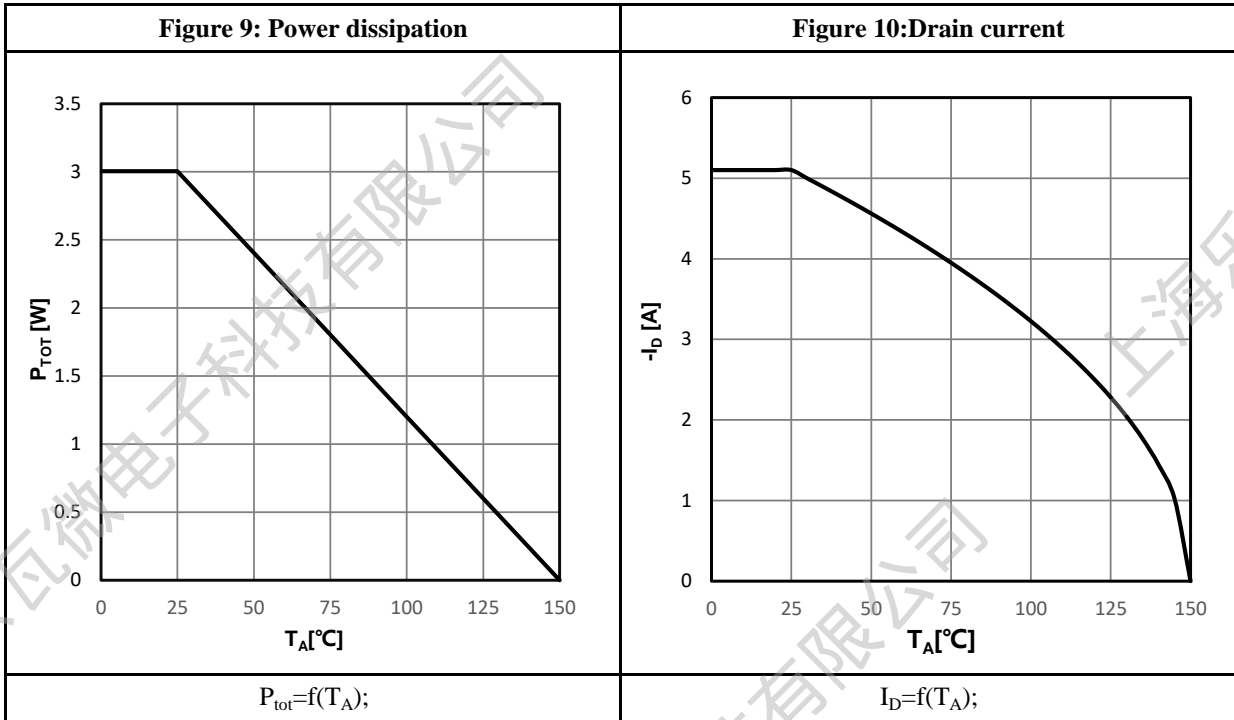

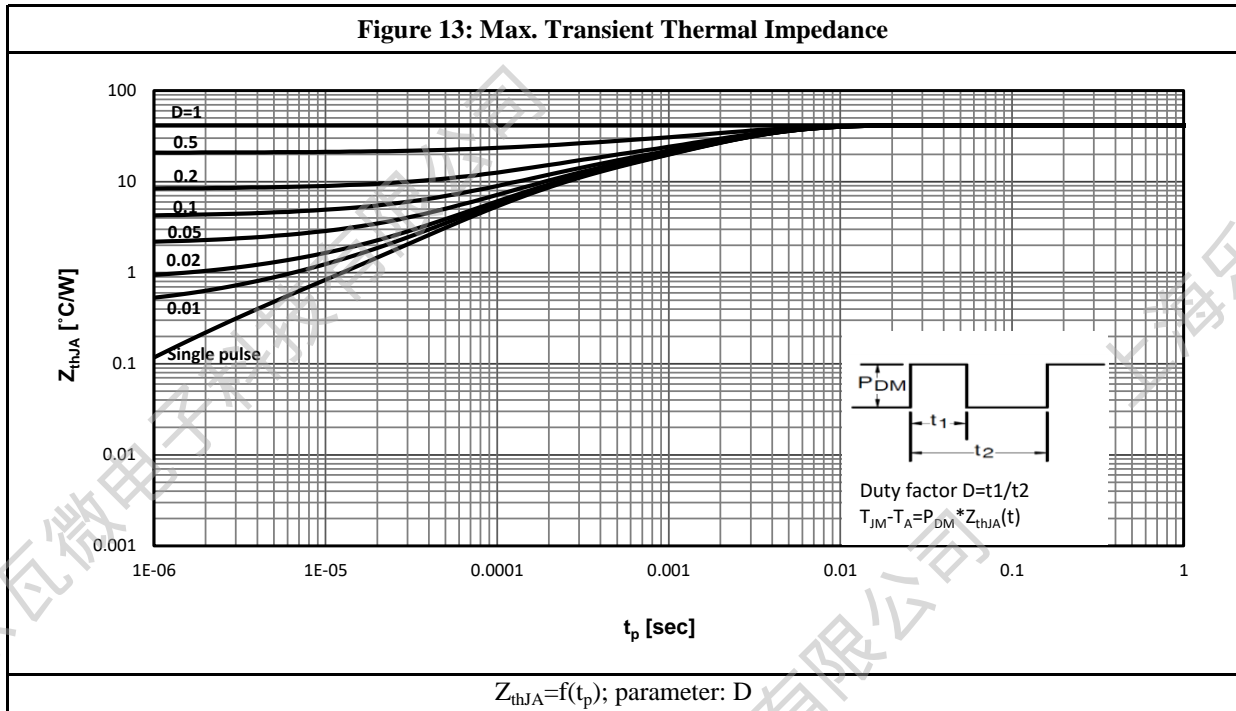

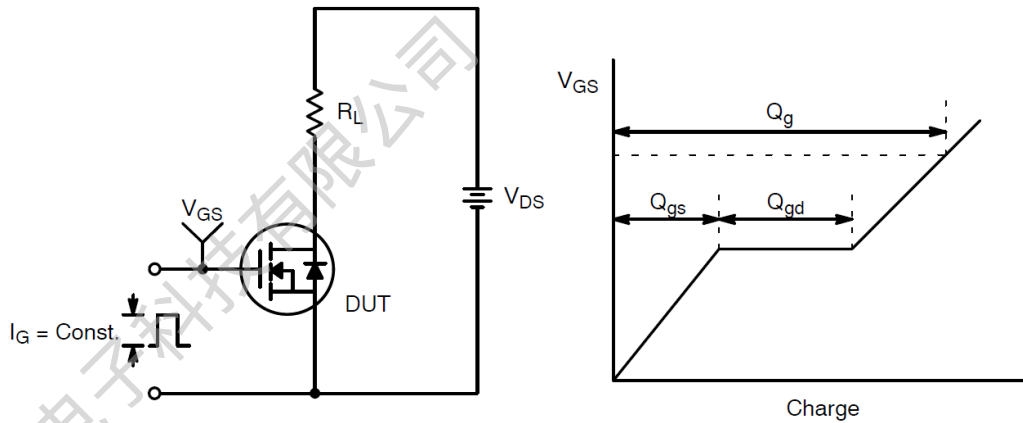
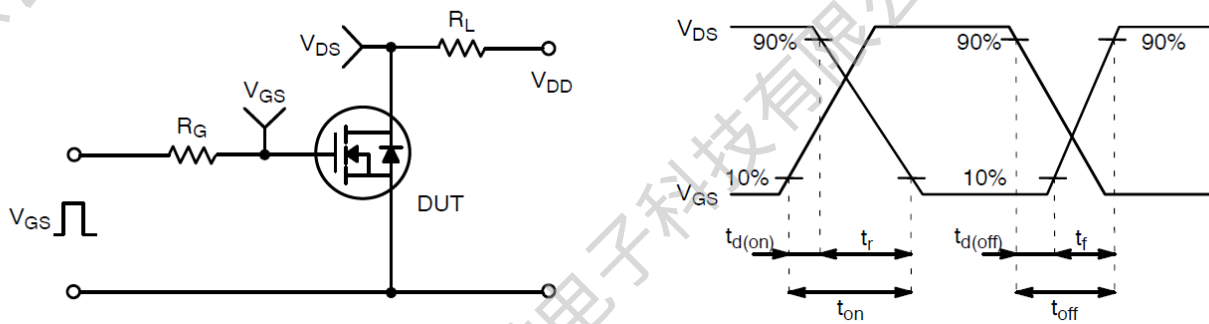
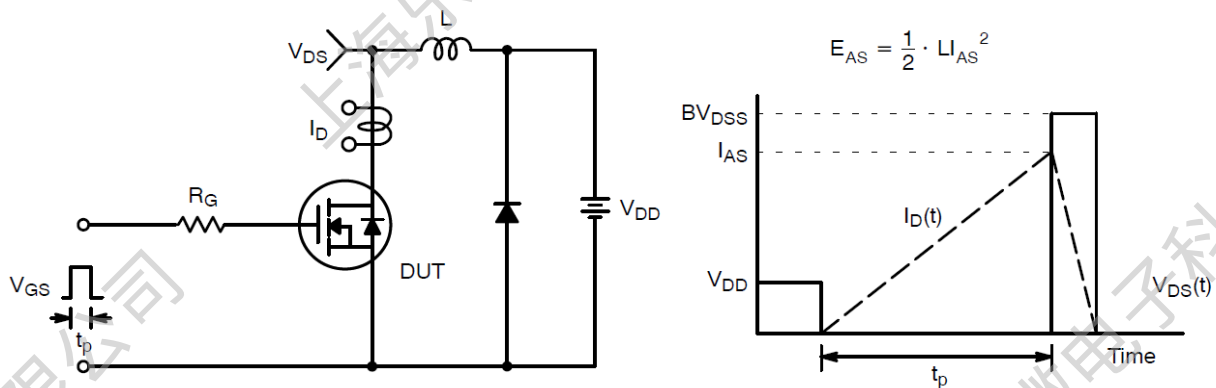
Test Circuit & Waveform:

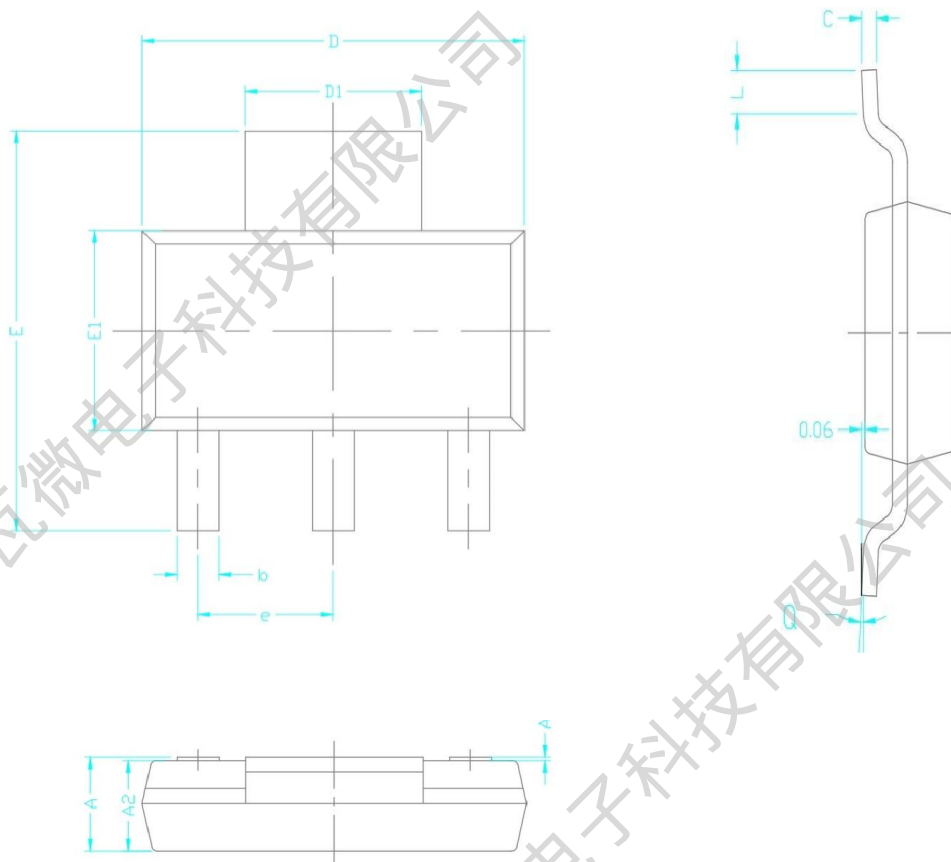
Figure 14: Gate Charge Test Circuit & Waveform

Figure 15: Resistive Switching Test Circuit & Waveforms

Figure 16: Unclamped Inductive Switching Test Circuit & Waveforms

Package Outline:

COMMON DIMENSION (MM)			
PKG	TO-223		
Symbol	MIN	NOM	MAX
A	1.520	1.580	1.720
A1	0.010	0.060	0.150
A2	1.470	1.520	1.570
b	0.660	0.710	0.800
C	0.250	0.280	0.350
D	6.500	6.600	6.750
D1	2.900	3.000	3.100
E	6.700	7.000	7.300
E1	3.300	3.500	3.700
L	0.750 REF		
e	2.300 REF		
Q	0°	4°	10°

Revision History:

Revison	Date	Descriptions
Rev 1.0	Dec.2021	Initial Version

Disclaimer:

The information in this document is believed to be accurate and reliable. However, no responsibility is assumed by LW-Micro for its use. All operating parameters must be designed, validated and tested to ensure they meet the requirements of your application. LW-Micro reserves the right to make any specification and/or circuitry changes without prior notification. Before starting a brand-new project, please contact LW-Micro Sales to get the most recent relevant information.

Mailing Address: Room 301, Building 2, No.1690 CaiLun Road, China (Shanghai) Pilot Free Trade Zone
Shanghai Lewa Micro-electronics Technology Co., Ltd

X-ON Electronics

Largest Supplier of Electrical and Electronic Components

Click to view similar products for [MOSFET](#) category:

Click to view products by [Lewa Micro](#) manufacturer:

Other Similar products are found below :

[IRFD120](#) [IRFY240C](#) [JANTX2N5237](#) [2SK2267\(Q\)](#) [BUK455-60A/B](#) [MIC4420CM-TR](#) [VN1206L](#) [NDP4060](#) [SI4482DY](#)
[IPS70R2K0CEAKMA1](#) [SQD23N06-31L-GE3](#) [TK16J60W,S1VQ\(O](#) [2SK2614\(TE16L1,Q\)](#) [DMN1017UCP3-7](#) [EFC2J004NUZTDG](#)
[DMN1053UCP4-7](#) [SQJ469EP-T1-GE3](#) [NTE2384](#) [DMC2700UDMQ-7](#) [DMN2080UCB4-7](#) [DMN61D9UWQ-13](#) [US6M2GTR](#)
[DMN31D5UDJ-7](#) [DMP22D4UFO-7B](#) [DMN1006UCA6-7](#) [DMN16M9UCA6-7](#) [STF5N65M6](#) [IRF40H233XTMA1](#) [STU5N65M6](#)
[DMN6022SSD-13](#) [DMN13M9UCA6-7](#) [DMTH10H4M6SPS-13](#) [DMN2990UFB-7B](#) [IPB80P04P405ATMA2](#) [2N7002W-G](#) [MCAC30N06Y-](#)
[TP](#) [MCQ7328-TP](#) [NTMC083NP10M5L](#) [NVMFS2D3P04M8LT1G](#) [BXP7N65D](#) [BXP4N65F](#) [AOL1454G](#) [WMJ80N60C4](#) [BXP2N20L](#)
[BXP2N65D](#) [BXT1150N10J](#) [BXT1700P06M](#) [TSM60NB380CP](#) [ROG](#) [RQ7L055BGTCR](#) [DMNH15H110SK3-13](#)