

Lexar microSD3.0 UHS-I Specification

Revision History:

Rev.	Date	Changes	Remark
A0	2018/07	Initial release	

NOTE: INFORMATION IN THIS PRODUCT SPECIFICATION IS SUBJECT TO CHANGE AT ANYTIME WITHOUT NOTICE, ALL PRODUCT SPECIFICATIONS ARE PROVIDED FOR REFERENCE ONLY. TO ANY INTELLECTUAL, PROPERTY RIGHTS IN LEXAR CO.,LTD. ALL INFORMATION IN THIS DOCUMENT IS PROVIDED.

Contents

1. Overview	3
1.1 Product Description	3
1.2 Features Summary	3
2. Pin Assignment	4
3. Product List	5
4. Current Consumption	6
5. Reliability and Durability	7
6. SD Card Registers	8
6.1 Card Identification Register (CID)	8
6.2 Card Specific Data Register (CSD)	8
7. Bus Operation Conditions	10
7.1 For 3.3V Signaling	10
7.1.1 Threshold Level for High Voltage Range	10
7.1.2 Peak Voltage and Leakage Current	10
7.1.3 Bus Signal Line Load	10
7.1.4 Bus Signal Levels	11
7.1.5 Bus Timing(Default)	11
7.1.6 Bus Timing(High-Speed Mode)	13
7.2 For 1.8V Signaling	14
7.2.1 Threshold Level for High Voltage Range	14
7.2.2 Peak Voltage and Leakage Current	14
7.2.3 Bus Timing Specification in SDR12, SDR25, SDR50 and SDR104 Modes	14
7.2.3.1 Clock Timing	14
7.2.3.2 Card Input Timing	15
7.2.3.3 Card Output Timing	16
7.2.3.3.1 Output Timing of Fixed Data Window (SDR12, SDR25 and SDR50)	16
7.2.3.3.2 Output Timing of Variable Window (SDR104)	16
8. Physical Dimension	17

1. Overview

1.1 Product Description

The microSD3.0 Cards are fully compatible with Physical Layer Specification, Version 3.0 (this specification is available from the SDA), support Ultra High Speed(UHS), provides high write/read speed and high IOPS, It was designed to meet the security, high capacity, high performance and environmental requirements inherent in next generation consumer electronic devices.

The SD card system is a new mass-storage system based on innovations in semiconductor technology. It has been developed to provide an inexpensive, mechanically robust storage medium in card form for multimedia consumer applications. SD card allows the design of inexpensive players and drivers without moving parts. A low power consumption and a wide supply voltage range favors consumer electronic devices.

Ultra High Speed (UHS) Card

It provides up to 104MB/s* performance. UHS cards are backward compatible on non-UHS hosts.

*Based on internal testing; performance may vary depending upon host device.

1 megabyte(MB)=1,000,000bytes.

1.2 Features Summary

- Capacity: 8GB/16GB/32GB/64GB
- Complies to SD specifications version 3.00
- Voltage operating: 2.7~3.6V.
- Targeted for portable and stationary applications
- Greater Performance Choices
- Bus Speed Mode:
 - DS-Default Speed mode: 3.3V signaling, frequency up to 25MHz, up to 12.5MB/sec
 - HS-High Speed mode: 3.3V signaling, frequency up to 50MHz, up to 25MB/sec
 - SDR12-1.8V signaling, frequency up to 25MHz, up to 12.5MB/sec
 - SDR25-1.8V signaling, frequency up to 50MHz, up to 25MB/sec
 - SDR50-1.8V signaling, frequency up to 100MHz, up to 50MB/sec
 - SDR104-1.8V signaling, frequency up to 208MHz, up to 104MB/sec
 - DDR50-1.8V signaling, frequency up to 50MHz, sampled on both clock edges, up to 50MB/s
- Switch function command supports Bus Speed Mode, Command System, Drive Strength, and future functions.
- password protection (CMD42-LOCK_UNLOCK)
- Sophisticated system for error recovery including a powerful ECC
- Global Wear Leveling
- Power management for low power operation
- Add TF card adapter can be used in SD card socket

2. Pin Assignment

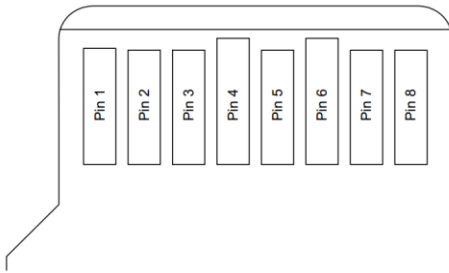

Pin No.	SD Mode			SPI Mode		
	Name	Type	Description	Name	Type	Description
1	Dat2	I/O/PP	Data Line [Bit 2]	RSV		Reserved
2	CD/DAT3	I/O/PP	Card Detect / Data Line [Bit 3]	CS	I	Chip Select
3	CMD	PP	Command/Response	DI	I	Data In
4	VDD	S	Supply voltage	VDD	S	Supply voltage
5	CLK	I	Clock	SCLK	I	Clock
6	VSS	S	Supply voltage ground	VSS	S	Supply voltage ground
7	DAT0	I/O/PP	Data Line [Bit 0]	DO	O/PP	Data Out
8	DAT1	I/O/PP	Data Line [Bit 1]	RSV		Reserved

S: power supply; I: input; O: output; PP: I/O using push-pull drivers

Table 1: Pin Assignment

3. Product List

Product	Lexar P/N	Capacity	Actual Size (byte)	Speed Class (Note1)	Write/Read Speed (Note1)	UHS-I (Note1)	Type
Commercial microSD 3.0	LCSDM-D1P01-8G	8GB	7,816,840,479	U1	10/90MB/s	SDR104	SDHC
	LCSDM-D1D02-16G	16GB	15,633,680,957	U1	20/90MB/s	SDR104	SDHC
	LCSDM-D1D03-32G	32GB	31,267,361,915	U1	20/90MB/s	SDR104	SDHC
	LCSDM-D1D03-64G	64GB	62,534,723,830	U1	30/90MB/s	SDR104	SDXC

Table 2: Product List

Note1: *Measurement based on VTE3100 TestMetrix device, SW 3.2A software or up version, test script:

SD_Card(Spec3.0_High&Extended-Capacity_UHS-I and Non-UHS-I)_Compliance [rev31R].vte
SDR104@SDR104-208MHz.

SD_Card (Spec2.0-3.0 High&Extended-Capacity_UHS-I) Performance-Speed (Multiple Block Sequential) [rev31M] - SDR104-With Background Data.vte]

**Maximum speed differs from the bus I/F speed. It varies depending upon the card performance. The average speed that a device writes to an SD memory card may vary depending upon the device and the operation it is performing. Normal and high-speed cards can also be used with UHS-I host devices, but the high performance enabled by a UHS-I host device can only be achieved with a UHS-I memory card*

4. Current Consumption

Standby current: 500uA (Maximum value)

Standby current: 250uA (average value)

Operating current: 250mA (Maximum value)

Operating current: 150mA (average value)

*Test condition: Realtek5308 card reader (Voltage 3.3V), Fluke289C multi-meter.

Lexar Confidential

5. Reliability, Durability and Endurance

Temperature	Operation: 0°C/70°C Storage: -25°C/85°C
Moisture and corrosion	Operation: 25°C/95% rel. humidity Storage: 40°C/93% rel. hum./500h Salt Water Spray: 3% NaCl/35C; 24h acc. MIL STD Method 1009
Durability	10,000 mating cycles;
Bending	10[N] Center 200[mm/minute] 60[sec]
Torque	0.15Nm, +/-2.5 deg.max.
Drop test	1.5m free fall
Electrostatic Discharge (ESD)	IEC 61000-4-2 contact discharge: +/- 2[kV] and +/- 4[kV] 150[pF],330 [Ohm] air discharge: up to +/- 15[kV] 150[pF], 330[Ohm]
TBW(Terabytes Written)	8GB: 3.5TB 16GB: 7TB 32GB: 14TB 64GB: 28TB

Table 3: Reliability and Durability

6. SD Card Registers

6.1 Card Identification Register (CID)

The Card Identification (CID) register is 128 bit wide. It contains the card identification information used during the card identification phase. Every individual flash card shall have a unique identification number.

The structure of the CID register is defined in the following table.

CID Bit	Width	Name	Field
[127:120]	8	Manufacture ID	MID
[119:104]	16	OEM/Application ID	OID
[103:64]	40	Product Name	PNM
[63:56]	8	Product Revision	PRV
[55:24]	32	Product Serial Number	PSN
[23:20]	4	Reserved	---
[19:8]	12	Manufacturing Date	MDT
[7:1]	7	CRC7 check sum	CRC
[0]	1	Not used,always"1	---

Table 4: SD Card CID Table

- All contents in the CID table are programmable; Manufacturers can update the CID data through utility.
- Manufacturers should license MID and OID field form the SD Card Association(SDA)

6.2 Card Specific Data Register (CSD)

The Card-Specific Data register provides information on how to access the card contents. The defines the data format, error correction type, maximum data access time, data transfer speed, whether the DSR register can be used etc. The programmable part of the register can be can be changed by CMD27.The CSD Table Version 2.0(as shown below) is applied to SDHC and SDXC Cards. Note that bits [15:0] are programmable by the host side. Refer to the SD specification for detailed information

CSD Bit	Width	Name	Field	Value	Note
[127:126]	2	CSD structure	CSD_STRUCTURE	01b	V2.0(>2G B Card)
[125:120]	6	Reserved	---	---	---
[119:112]	8	Data read access-time 1	(TAAC)	0E h	
[111:104]	8	Data read access-time2 in CLK cycles(NSA*100)	(NSAC)	00 h	
[103:96]	8	Max data transfer rate	(TRAN_SPEED)	32 h 5A h 0B h 2B h	
[95:84]	12	Card command classes	CCC	5B5 h	

[83:80]	4	Max. read data block length	(READ_BL_LEN)	9 h	512 Byte
[79]	1	Partial block read allowed	(READ_BL_PARTIAL)	0	
[78]	1	Write block misalignment	(WRITE_BLK_MISALIGN)	0	
[77]	1	Read block misalignment	(READ_BLK_MISALIGN)	0	
[76]	1	DSR implemented	DSR_IMP	x	
[75:70]	6	Reserve	---	---	
[69:48]	22	Device size	C_SIZE	xxxxxxh	
[47]	1	Reserved	---	0	
[46]	1	Erase single block enable	(ERASE_BLK_EN)	1	
[45:39]	7	Erase sector size	(SECTOR_SIZE)	7F h	
[38:32]	7	Write protect group size	C_SIZE	0 b	
[31]	1	Write protect group enable	---	0	
[30:29]	2	Reserved	(ERASE_BLK_EN)	0 b	
[28:26]	3	Write speed factor	(SECTOR_SIZE)	010 b	
[25:22]	4	Max. write data block length	(WP_GRP_SIZE)	9 h	
[21]	1	Partial block write allowed	(WP_GRP_ENABLE)	0	
[20:16]	5	Reserved	---	---	
[15]	1	File format group	(FILE_FORMAT_GRP)	0	
[14]	1	Copy flag	COPY	x	
[13]	1	Permanent write protection	PERM_WRITE_PROTECT	x	
[12]	1	Temporary write protection	TMP_WRITE_PROTECT	x	
[11:10]	2	File format	(FILE_FORMAT)	00 b	
[9:8]	2	Reserved	---	00 b	
[7:1]	7	CRC	CRC	---	
[0]	1	Not used,always'1'	---	1	

Table 5: CSD (Version 2.0) Table

7. Bus Operation Conditions

7.1 For 3.3V Signaling

7.1.1 Threshold Level for High Voltage Range

Parameter	Symbol	Min	Max	Unit	Remark
Supply Voltage	V _{DD}	2.7	3.6	V	
Output High Voltage	V _{OH}	0.75* V _{DD}		V	I _{OH} =2mA V _{DD min}
Output Low Voltage	V _{OL}		0.125* V _{DD}	V	I _{OL} =2mA V _{DD min}
Input High Voltage	V _{IH}	0.625* V _{DD}	V _{SS} +0.3	V	
Input Low Voltage	V _{IL}	V _{SS} -0.3	0.25* V _{DD}	V	
Power Up Time			250	ms	From 0V to V _{DD min}

Table 6: Threshold Level for High Voltage

7.1.2 Peak Voltage and Leakage Current

Parameter	Symbol	Min	Max	Unit	Remark
Peak voltage on all lines		-0.3	V _{DD} +0.3	V	
All Inputs					
Input Leakage Current		-10	10	uA	
All Outputs					
Output Leakage Current		-10	10	uA	

Table 7: Peak Voltage and Leakage Current

7.1.3 Bus Signal Line Load

Parameter	Symbol	Min	Max	Unit	Remark
Pull-up resistance	R _{CMD} R _{DAT}	10	100	K Ω	To prevent bus floating
Total bus capacitance for each signal line	C _L		40	pF	1 card C _{HOST} +C _{BUS} shall not exceed 30pF
Card capacitance for each signal pin	C _{CARD}		10	pF	
Maximum signal inductance			16	nH	
Pull-up resistance inside card(pin1)	R _{DAT3}	10	90	K Ω	May be used for card detection
Capacity Connected to Power Line	C _C		5	uF	To prevent inrush current

Table 8: Bus Operating Conditions - Signal Line's Load

7.1.4 Bus Signal Levels

As the bus can be supplied with a variable supply voltage, all signal levels are related to the supply voltage.

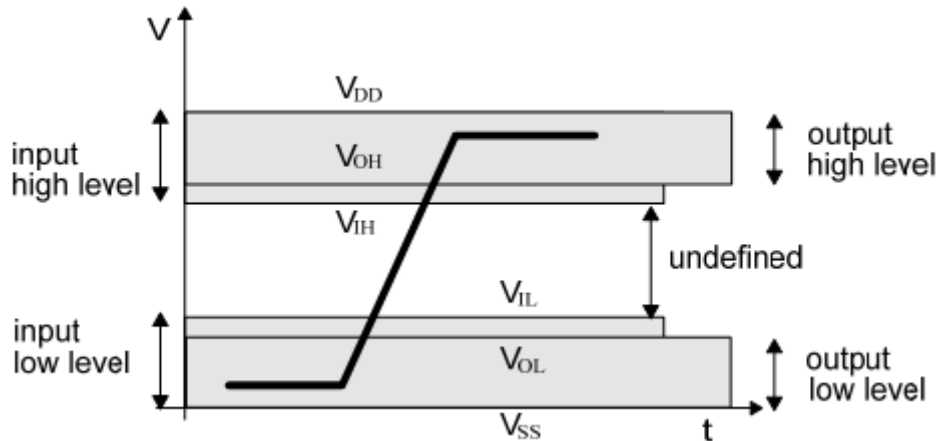

Figure 1: Bus Signal Levels

To meet the requirements of the the JEDEC specification JESD8-1A and JESD8-7, the card input and output voltages shall be within the specifide ranges shown in Table 6-2 for any V_{DD} of the allowed voltage range:

7.1.5 Bus Timing(Default)

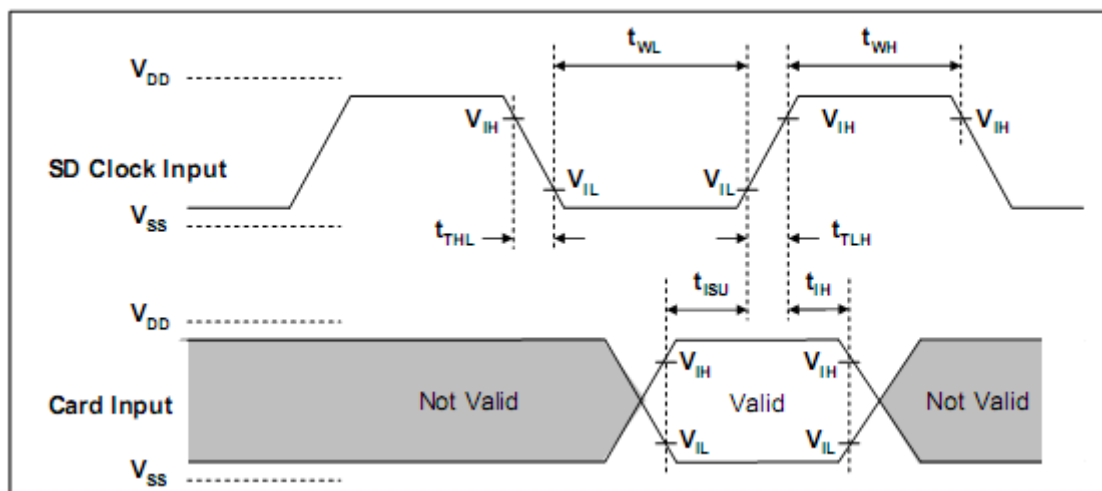

Figure 2: Card input Timing(Default Speed Card)

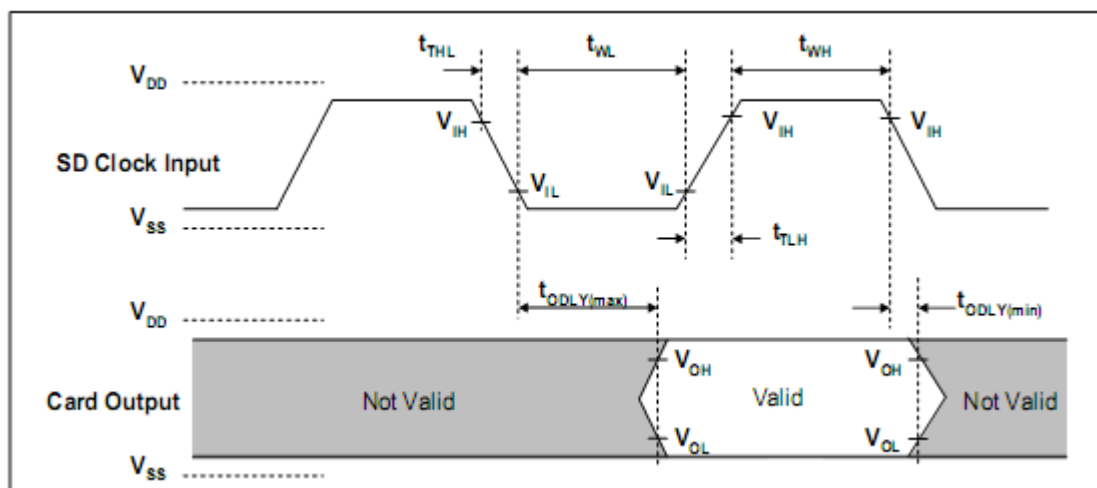

Figure 3: Card Output Timing(Default Speed Mode)

Parameter	Symbol	Min.	Max	Unit	Remark
Clock CLK (All values are referred to min (V _{IH}) and max (V _{IL}))					
Clock frequency data transfer	f _{pp}	0	25	MHz	C _{CARD} ≤ 10pF (1 card)
Clock frequency Identification	f _{OD}	0 ⁽¹⁾ /100	400	KHz	C _{CARD} ≤ 10pF (1 card)
Clock low time	t _{WL}	10		ns	C _{CARD} ≤ 10pF (1 card)
Clock high time	t _{WH}	10		ns	C _{CARD} ≤ 10pF (1 card)
Clock rise time	t _{TLH}		10	ns	C _{CARD} ≤ 10pF (1 card)
Clock fall time	t _{THL}		10	ns	C _{CARD} ≤ 10pF (1 card)
Inputs CMD, DAT (referenced to CLK)					
Input set-up time	t _{ISU}	5		ns	C _{CARD} ≤ 10pF (1 card)
Input hold time	t _{IH}	5		ns	C _{CARD} ≤ 10pF (1 card)
Outputs CMD, DAT (referenced to CLK)					
Output Delay time during Data Transfer Mode	t _{ODLY}	0	14	ns	C _L ≤ 40pF (1 card)
Output Hold time	t _{OH}	0	50	ns	C _L ≤ 40pF (1 card)

(1) 0 Hz means to stop the clock. The given minimum frequency range is for cases where continuous clock is required (refer to Chapter 4.4-Clock Control)

Table 9: Bus Timing-Parameters Values (Default Speed)

7.1.6 Bus Timing(High-Speed Mode)

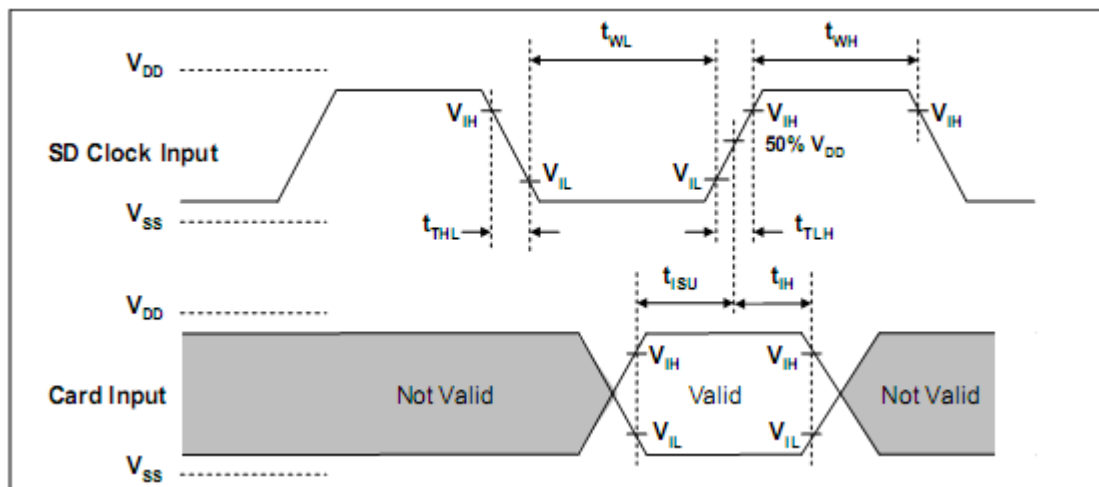

Figure 4:Card Input Timing(High Speed Card)

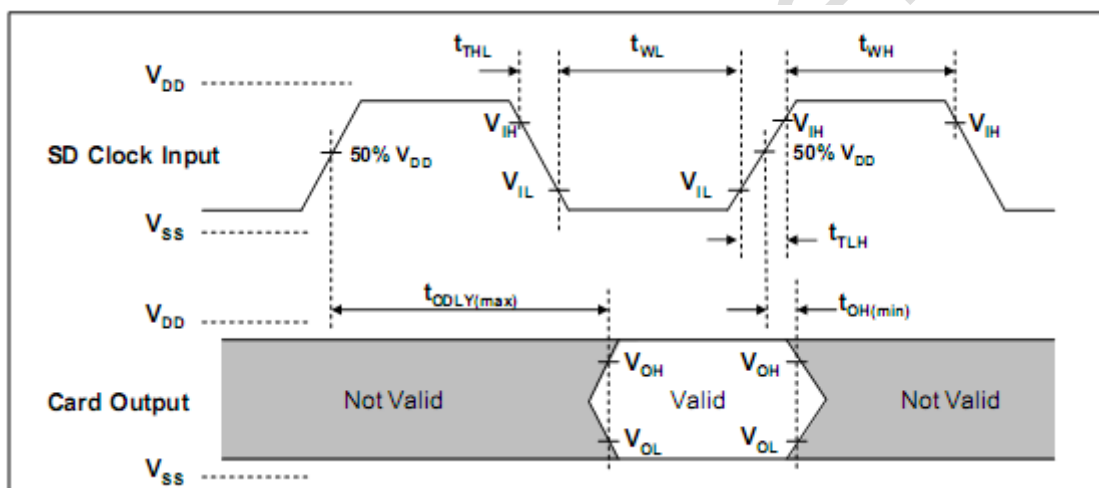

Figure 5: Card Output Timing(High Speed Mode)

Parameter	Symbo	Min.	Max	Unit	Remark
Clock CLK (All values are referred to min (V_{IH}) and max (V_{IL}))					
Clock frequency data transfer	fpp	0	50	MHz	$C_{CARD} \leq 10pF$ (1 card)
Clock low time	t_{WL}	7		ns	$C_{CARD} \leq 10pF$ (1 card)
Clock high time	t_{WH}	7		ns	$C_{CARD} \leq 10pF$ (1 card)
Clock rise time	t_{TLH}		3	ns	$C_{CARD} \leq 10pF$ (1 card)
Clock fall time	t_{THL}		3	ns	$C_{CARD} \leq 10pF$ (1 card)
Inputs CMD, DAT (referenced to CLK)					
Input set-up time	t_{ISU}	6		ns	$C_{CARD} \leq 10pF$ (1 card)
Input hold time	t_{IH}	2		ns	$C_{CARD} \leq 10pF$ (1 card)

Outputs CMD, DAT (referenced to CLK)					
Output Delay time during Data Transfer Mode	t_{ODLY}		14	ns	$C_L \leq 40\text{pF}$ (1 card)
Output Hold time	t_{OH}	2.5		ns	$C_L \geq 15\text{pF}$ (1 card)
Total System capacitance for each line ¹	C_L		40	pF	1 card

1) In order to satisfy sever timing , host shall drive only one card.

Table 10 :Bus Tinming – Parameters Values(High Speed)

7.2 For 1.8V Signaling

7.2.1 Threshold Level for High Voltage Range

Parameter	Symbol	Min	Max	Unit	Remark
Supply Voltage	V_{DD}	2.7	3.6	V	
Regulator Voltage	V_{DDIO}	1.7	1.95	V	Generated by V_{DD}
Output High Voltage	V_{OH}	1.4		V	$I_{OH}=2\text{mA } V_{DD \text{ min}}$
Output Low Voltage	V_{OL}		0.45	V	$I_{OL}=2\text{mA } V_{DD \text{ min}}$
Input High Voltage	V_{IH}	1.27	2.0	V	
Input Low Voltage	V_{IL}	$V_{SS}-0.3$	0.58	V	

Table 11: Threshold Level for High Voltage

7.2.2 Peak Voltage and Leakage Current

Parameter	Symbol	Min	Max	Unit	Remark
Input Leakage Current		-2	2	uA	DAT3 pull-up is disconnected

Table 12: Peak Voltage and Leakage Current

7.2.3 Bus Timing Specification in SDR12, SDR25, SDR50 and SDR104 Modes

7.2.3.1 Clock Timing

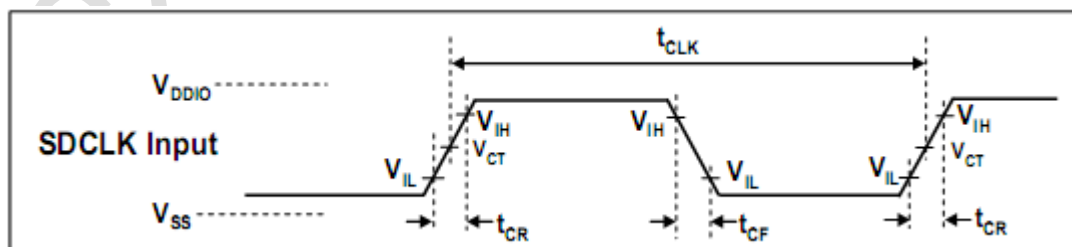

Figure 6: Clock Singnal Timing

Symbol	Min	Max	Unit	Remark
t_{CLK}	4.8	-	ns	208MHz (Max.), Between rising edge, $V_{CT}=0.975V$
t_{CR}, t_{CF}	-	$0.2 * t_{CLK}$	ns	$t_{CR}, t_{CF} < 2.00ns$ (max.) at 208MHz, $C_{CARD}=10pF$ $t_{CR}, t_{CF} < 2.00ns$ (max.) at 100MHz, $C_{CARD}=10pF$ The absolute maximum value of t_{CR}, t_{CF} is 10ns regardless of clock frequency.
Clock Duty	30	70	%	

Table 13: Clock Signal Timing

7.2.3.2 Card Input Timing

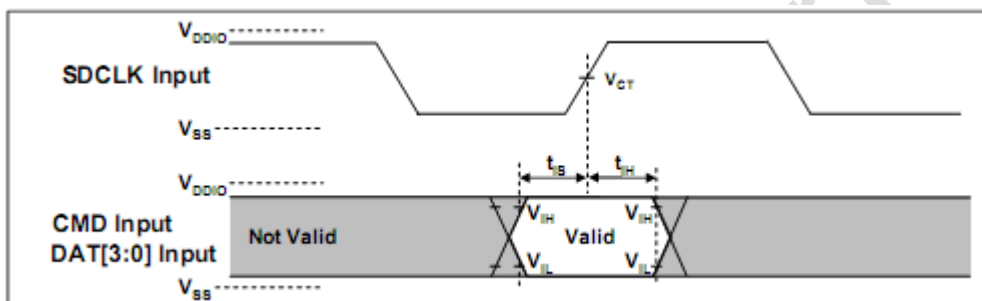

Figure 7: Card Input Timing

Symbol	Min	Max	Unit	SDR104 mode
t_{IS}	1.40	-	ns	$C_{CARD} = 10pF, V_{CT} = 0.975V$
t_{IH}	0.80	-	ns	$C_{CARD} = 5pF, V_{CT} = 0.975V$
Symbol	Min	Max	Unit	SDR12, SDR25 and SDR50 modes
t_{IS}	3.00	-	ns	$C_{CARD} = 10pF, V_{CT} = 0.975V$
t_{IH}	0.80	-	ns	$C_{CARD} = 5pF, V_{CT} = 0.975V$

Table 14: SDR50 and SDR104 Input Timing

7.2.3.3 Card Output Timing

7.2.3.3.1 Output Timing of Fixed Data Window (SDR12, SDR25 and SDR50)

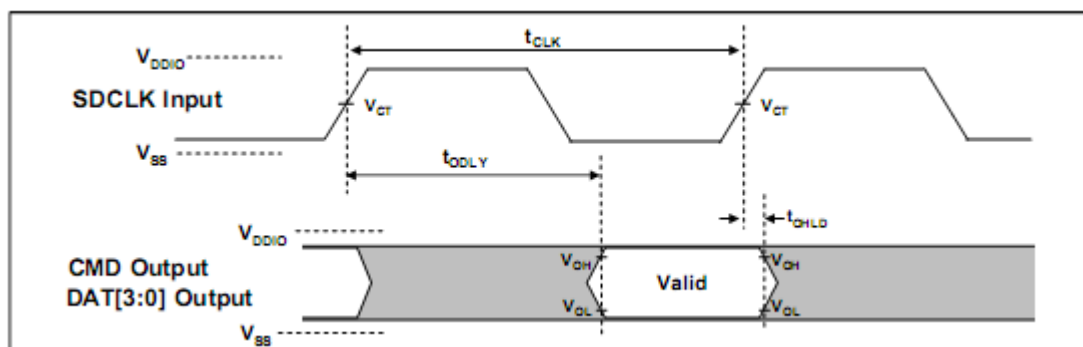

Figure 8: Output Timing of Fixed Data Window

Symbol	Min	Max	Unit	Remark
t_{ODLY}	-	7.5	ns	$t_{CLK} \geq 10.0ns$, $CL=30pF$, using driver Type B, for SDR50.
t_{ODLY}		14	ns	$t_{CLK} \geq 20.0ns$, $CL=40pF$, using driver Type B, for SDR25 and SDR12.
t_{OH}	1.5	-	ns	Hold time at the t_{ODLY} (min.). $CL=15pF$

Table 15: Output Timing of Fixed Data Window

7.2.3.3.2 Output Timing of Variable Window (SDR104)

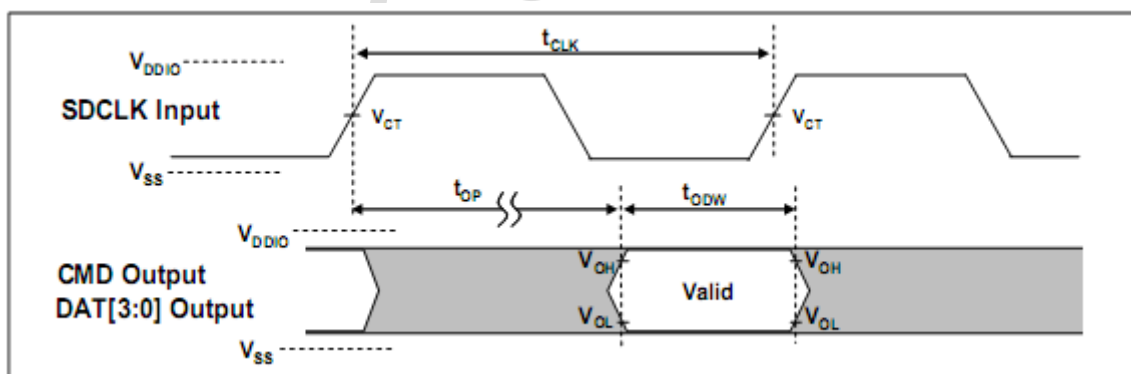

Figure 9: Output Timing of Variable Data Window

Symbol	Min	Max	Unit	Remark
t_{OP}	-	2	UI	Card Output Phase
Δt_{OP}	-350	+1550	ps	Delay variation due to temperature change after tuning
t_{ODW}	0.60	-	UI	$t_{ODW} = 2.88ns$ at 208MHz

Table 16: Output Timing of Variable Data Window

8. Physical Dimension

Type	Measurement
Length	15mm +/- 0.1mm(B)
Width	11mm +/- 0.1mm(A)
Thickness	1.0mm +/- 0.1mm(C)
	0.7mm +/- 0.1mm(C1)
Weight	0.33 gram Max

Table 17: Physical Dimension Specifications (Unit in mm)

Lexar Confidential

Mechanical form factor as follows: (Unit in mm)

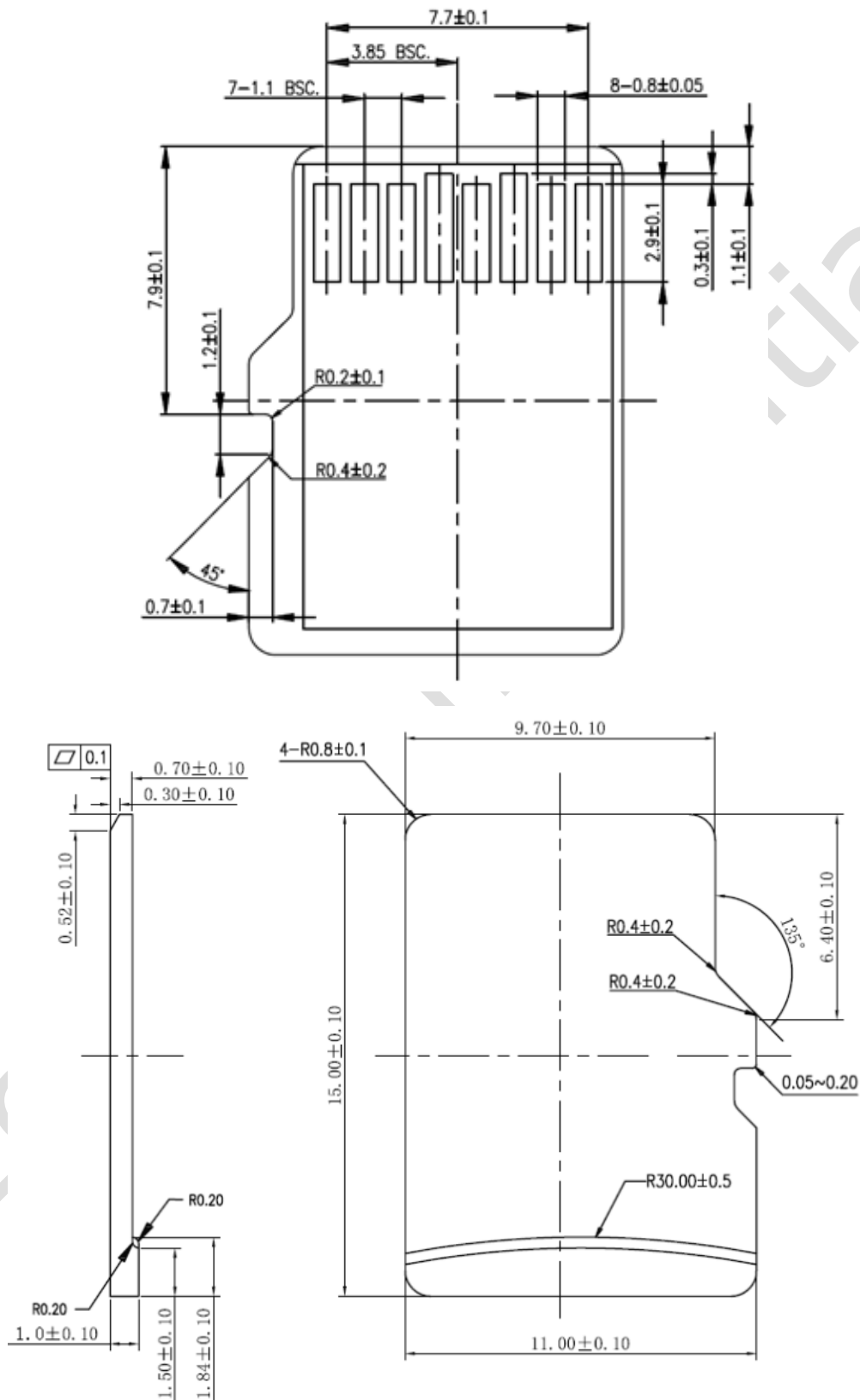

Figure 10: Dimension Drawing

X-ON Electronics

Largest Supplier of Electrical and Electronic Components

Click to view similar products for [Memory Cards](#) category:

Click to view products by [Lexar](#) manufacturer:

Other Similar products are found below :

[SQF-ISDS1-8G-21C](#) [SQF-S10M2-256G-S9E](#) [SQF-P10M1-4G-P9C](#) [CAE1B256GTFDWB00EAA0](#) [1061701](#) [CAE1B064GTFDWB00EAA0](#)
[CAE1B128GTFDWB00EAA0](#) [LMEX1L128GG2](#) [LMEX1L256GG2](#) [LNEX1L016GG4](#) [LNEX1L032GG4](#) [LNEX1L064GG4](#)
[LMEX1L016GG2](#) [LMEX1L032GG2](#) [LMEX1L064GG2](#) [SDUU1-008PDG](#) [SDUU1-0643SG](#) [SDUU1-1283SG](#) [SDC2GCPGRB](#)
[SDC2GGSGRB](#) [SDSDUN4-064G-GN6IN](#) [SDSDUN4-128G-GN6IN](#) [SDSDUN4-256G-GN6IN](#) [SDSQUA4-032G-GN6IA](#) [SDSQUA4-032G-](#)
[GN6MA](#) [SDSQUA4-064G-GN6IA](#) [SDSQUA4-064G-GN6MA](#) [SDSQUA4-128G-GN6IA](#) [SDSQUA4-128G-GN6MA](#) [SDSQUA4-256G-](#)
[GN6MA](#) [SDSQUA4-400G-GN6MA](#) [SDSQUNR-032G-GN3MN](#) [SDSQUNR-064G-GN3MN](#) [SDSQXAO-256G-GNCZN](#) [SDU4GCMGRB](#)
[SDUC6-002PCG](#) [SDSDAF4-256G-I](#) [SDSDAF4-512G-I](#) [SDSDQAF4-032G-I](#) [AP-CF016GKBNS-ETNRG](#) [AP-CF002GKBNS-ETNRG](#)
[SDSDAF4-064G-I](#) [MMM-3029-KNS](#) [HMC-EF283](#) [SDCFHS-016G-G46](#) [SDCFXPS-032G-X46](#) [SDSDB-016G-B35](#) [SDSDQAF3-032G-I](#)
[SDSDQAF3-064G-I](#) [SDSDQB-032G-B35](#)