

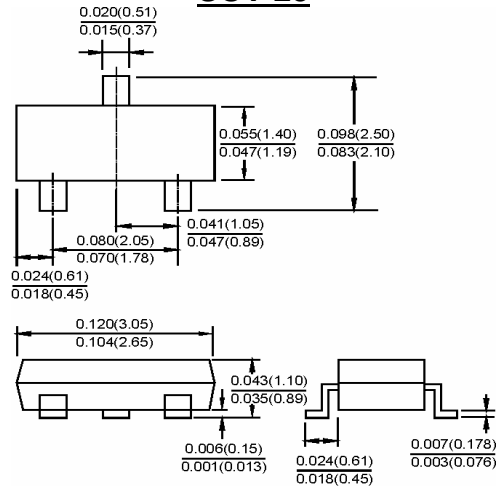

SOT-23



Dimensions in inches and (millimeters)

Features

- ✧ Fast switching speed
- ✧ Surface mount package ideally suited for automatic insertion
- ✧ For general purpose switching applications
- ✧ High conductance

Mechanical Data

- ✧ Case: SOT-23, Molded plastic
- ✧ Marking: BAW56: A1, BAV70: A4, BAV99: A7
- ✧ Weight: 0.008 gram (approx.)

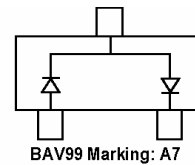
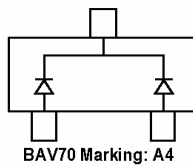
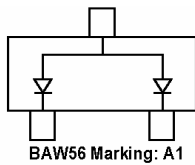

| Maximum Ratings $T_A=25^{\circ}\text{C}$ unless otherwise specified | | | | |
|---|-----------------|-------------------|-----------------------------|---------------|
| Type Number | Symbol | BAW56/BAV70/BAV99 | Units | |
| Reverse Voltage | V_R | 75 | V | |
| Forward Current | I_F | 200 | mA | |
| Peak Forward Surge Current | $I_{FM(surge)}$ | 500 | mA | |
| Power Dissipation | P_D | 225 | mW | |
| Thermal Resistance Junction to Ambient Air | $R_{\theta JA}$ | 556 | $^{\circ}\text{C}/\text{W}$ | |
| Junction Temperature | T_J | 150 | $^{\circ}\text{C}$ | |
| Storage Temperature Range | T_{STG} | -55 to 150 | $^{\circ}\text{C}$ | |
| Electrical Characteristics | | | | |
| Type Number | Symbol | Min | Max | Units |
| Reverse Breakdown Voltage | V_R | 75 | | V |
| Forward Voltage | V_F | | 0.715 | V |
| | | | 0.855 | |
| | | | 1.0 | |
| | | | 1.25 | |
| Reverse Current | I_R | | 30 | nA |
| | | | 2 | μA |
| Capacitance between terminals $V_R=0, f=1.0\text{MHz}$ | C_j | - | 1.5 | pF |
| Reverse Recovery Time (Note 1) | t_{rr} | - | 6.0 | nS |

Note 1: Reverse Recovery Test Conditions: $I_F=I_R=10\text{mA}$, $I_{rr}=0.1 \times I_R$, $R_L=100\Omega$.

RATINGS AND CHARACTERISTIC CURVES (BAW56/BAV70/BAV99)

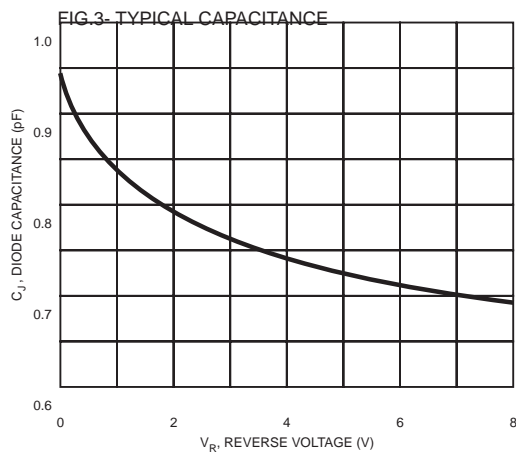
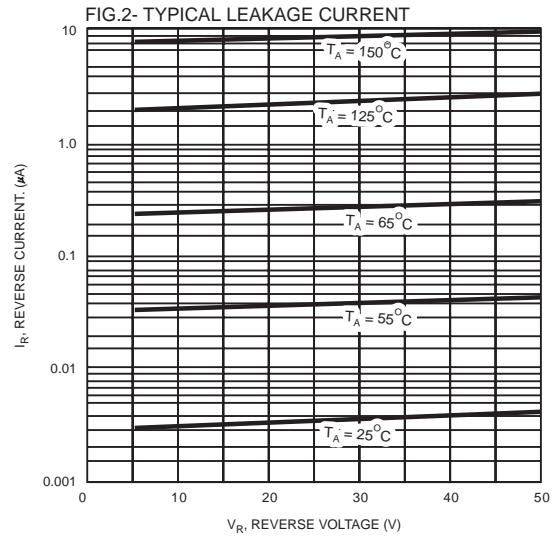
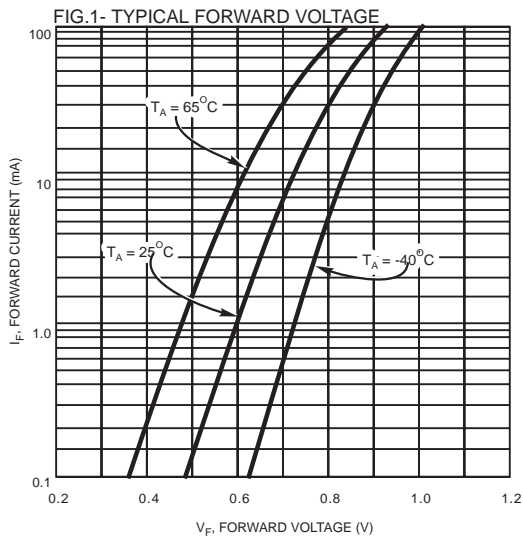

| PACKAGE | SPQ/PCS | CARTON SPQ/PCS | CARTON SIZE/CM | CARTON GW/KG | CARTON NW/KG |
|---------|-----------|-------------------|-------------------|-----------------|-----------------|
| SOT-23 | 3000/REEL | 90000 | 40X20X22 | 5.00 | 4.00 |

X-ON Electronics

Largest Supplier of Electrical and Electronic Components

Click to view similar products for [Diodes - General Purpose, Power, Switching category](#):

Click to view products by [LGE manufacturer](#):

Other Similar products are found below :

[MCL4151-TR3](#) [MMBD3004S-13-F](#) [RD0306T-H](#) [1N3611](#) [NTE156A](#) [NTE574](#) [NTE6244](#) [1SS193,LF](#) [1SS400CST2RA](#) [SDAA13](#)
[SHN2D02FUTW1T1G](#) [LS4151GS08](#) [1N4449](#) [1N456A](#) [1N4934-E3/73](#) [1N914BTR](#) [RFUH20TB3S](#) [D291S45T](#) [BAV300-TR](#) [BAW56DWQ-](#)
[7-F](#) [BAW56M3T5G](#) [BAW75-TAP](#) [MM230L-CAA](#) [IDW40E65D1](#) [JAN1N3600](#) [JAN1N4454UR-1](#) [LL4151-GS18](#) [SMMSD4148T3G](#)
[BYW95B/A52A](#) [NSVDAN222T1G](#) [CDSZC01100-HF](#) [LL4150-M-08](#) [1N4454-TR](#) [BAV70HDW-7](#) [BAS28-7](#) [JANTX1N6640](#) [BAW56HDW-](#)
[13](#) [BAS28 TR](#) [VS-HFA04SD60STR-M3](#) [NSVM1MA152WKT1G](#) [1SS388-TP](#) [RGP30D-E3/73](#) [VS-8EWF02S-M3](#) [BAV99TQ-13-F](#)
[BAV99HDW-13](#) [MMDB30-E28X](#) [IDP20C65D2XKSA1](#) [LS4148](#) [IDV15E65D2](#) [NSVM1MA152WAT1G](#)