

FEATURES

- Rating to 1000V PRV
- Surge overload rating to 60 Amperes peak
- Reliable low cost construction utilizing molded plastic technique results in inexpensive product
- Lead solderable per MIL-STD-202 method 208

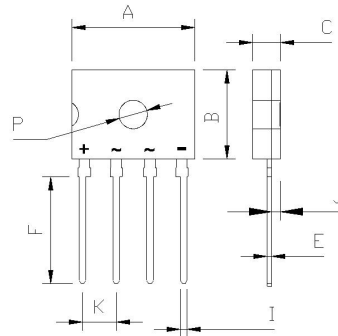

D3K		
Dim	Min	Max
A	13.65	14.15
B	9.80	10.20
C	2.95	3.25
E	0.35	0.65
F	11.70	12.30
I	0.65	0.95
J	0.90	1.20
K	3.60	4.00
P	Ø3.2Typical	
All Dimensions in mm		

Maximum Ratings (@TA = 25°C unless otherwise specified)

Characteristic	Symbol	LGE 3005	LGE 301	LGE 302	LGE 304	LGE 306	LGE 308	LGE 310	UNITS
Maximum recurrent peak reverse voltage	V_{RRM}	50	100	200	400	600	800	1000	V
Maximum RMS voltage	V_{RMS}	35	70	140	280	420	560	700	V
Maximum DC blocking voltage	V_{DC}	50	100	200	400	600	800	1000	V
50Hz sine wave, R-load Without heat sink Ta=25°C	$I_{F(AV)}$	3.0							A
Peak forward surge current 8.3ms single half-sine-wave superimposed on rated load	I_{FSM}	90							A
I^2t Rating for fusing @Tj=25°C	I^2t	33.6							A ² S

Thermal Characteristics

Characteristic	Symbol	Value	UNITS
Typical Thermal Resistance (Note)	$R_{\theta JA}$	13.7	°C/W
	$R_{\theta JC}$	5.2	
	$R_{\theta JL}$	5.5	
Operating junction temperature range	T_J	- 55 ---- + 150	°C
Storage temperature range	T_{STG}	- 55 ---- + 150	°C

Electrical Characteristics (@TA = 25°C unless otherwise specified)

Characteristic	Symbol	Value	UNITS
Maximum instantaneous forward voltage @1.5A	V_F	1.0	V
Maximum reverse current at rated DC blocking voltage	I_R	@TA=25 °C	5.0
		@TA=100°C	500
			μ A

RATINGS AND CHARACTERISTICS CURVES

($T_A = 25^\circ\text{C}$ unless otherwise noted)

Fig1. Maximum Derating Curve For Output current

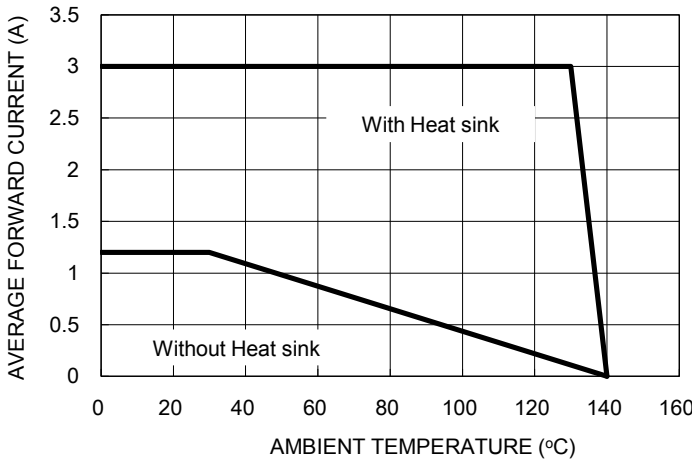

Fig2. Maximum Forward Surge Current

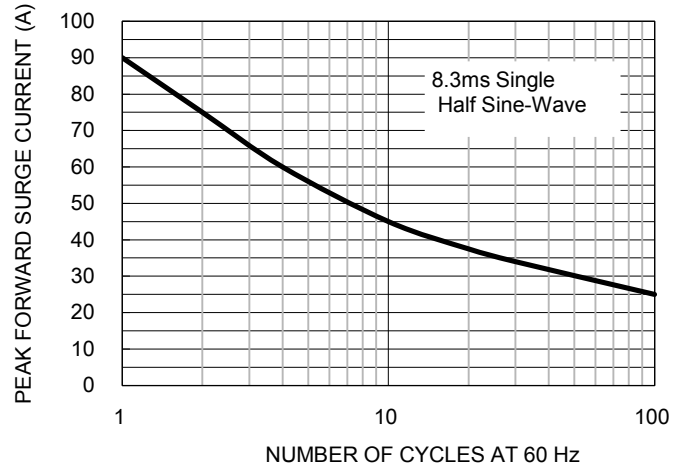

Fig3. Typical Reverse Characteristics

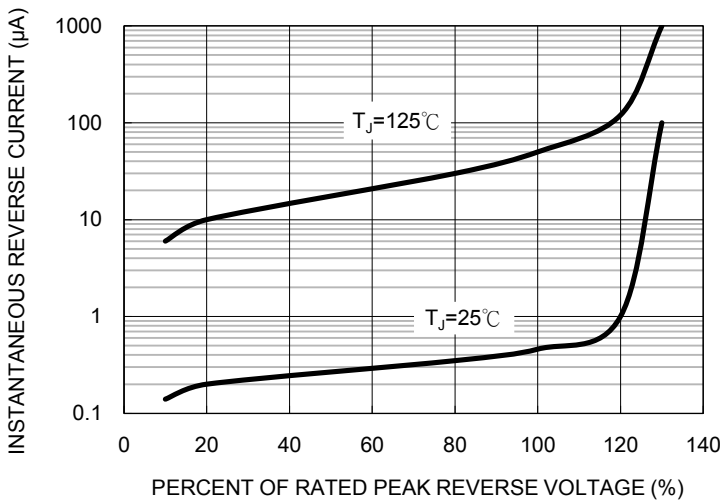
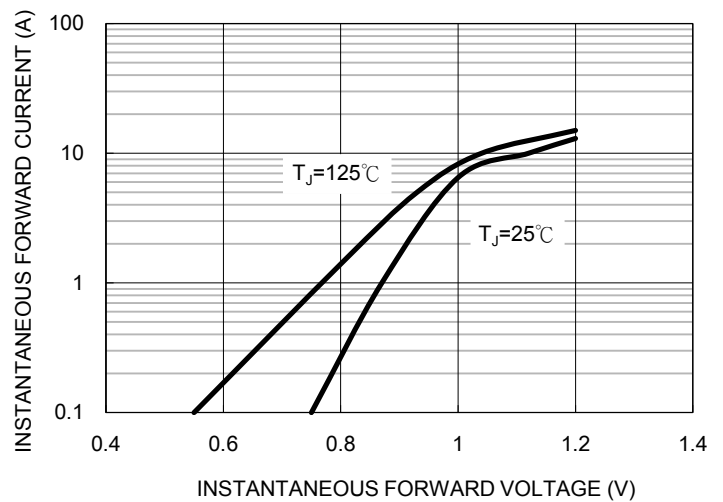

Fig4. Typical Forward Characteristics



X-ON Electronics

Largest Supplier of Electrical and Electronic Components

Click to view similar products for [Bridge Rectifiers](#) category:

Click to view products by [LGE](#) manufacturer:

Other Similar products are found below :

[MB252](#) [MB356G](#) [MB358G](#) [GBJ1504-BP](#) [GBU10B-BP](#) [GBU15K-BP](#) [GBU4A-BP](#) [GBU4D-BP](#) [DB101-BP](#) [DF01](#) [DF10SA-E345](#) [KBPC50-10S](#) [RS405GL-BP](#) [GBJ1502-BP](#) [GBU6M](#) [TB102M](#) [MB1510](#) [MB86](#) [TL401G](#) [MDA920A2](#) [TU602](#) [TU810](#) [MP5010W-BP](#) [MP501W-BP](#) [MP502-BP](#) [KBPC25-02](#) [VBO160-12NO7](#) [VS-110MT120KPBF](#) [VS-60MT80KPBF](#) [DB105-BP](#) [DF1510S](#) [VS-40MT160PAPBF](#) [GBU4G-BP](#) [GSIB15A80-E3/45](#) [DB104-BP](#) [D3SB60](#) [TB354](#) [GBJ2504-BP](#) [26MB100A](#) [B1S-G](#) [VS-40MT160KPBF](#) [VUO162-16NO7](#) [ABS10-G](#) [GBU6B-BP](#) [GBJ1508-BP](#) [BR5010-G](#) [ABS6-G](#) [B125C800G-E4/51](#) [MSB15MH-13](#) [LBS10-13](#)